

Component Image & Dimension

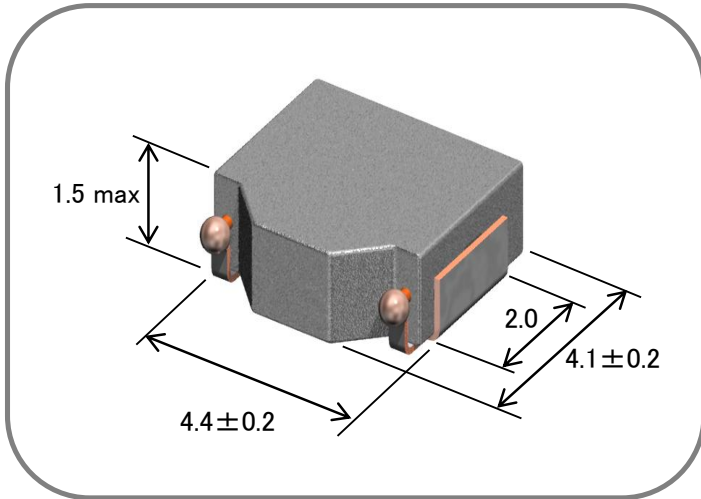

Features

- a) Small Footprint and Low Profile Design :
Footprint : 4.4 x 4.1 mm Typ.
Height : 1.5mm Max.
- b) High Power Handling Capability :
Small Copper Loss
Using Large Saturation Induction of Fe- based metals
- c) Flat inductance performance over temperature based on the high curie temperature of the iron powder core material.
- d) Automatic Mounting in Tape&Reel Package.

Applications

Note Book & Mobile Computer, VRM, Cellular Phone, HDD, Car accessories etc.

Electrical Specification

TDK Identification	Inductance		Test Freq. (kHz)	DC Resistance		Rated DC Current		
	at 0A (uH)	Tol. (%)		Spec. (m-Ohm)	Typ. (m-Ohm)	Idc 1 (A) max.	Idc 1 (A) typ.	Idc 2 (A) typ.
SPM4015T- R47M-CA	0.47	+/-20%	100	24.4 max	22.2	10.0	13.4	5.5
SPM4015T- 1R0M-CA	1.0	+/-20%	100	39.6 max	36.0	6.7	8.9	4.3
SPM4015T- 1R5M-CA	1.5	+/-20%	100	56.0 max	51.0	4.4	5.8	3.7
SPM4015T- 2R2M-CA	2.2	+/-20%	100	71.0 max	64.5	4.3	5.8	3.1
SPM4015T- 3R3M-CA	3.3	+/-20%	100	128.0 max	116.4	2.9	3.9	2.3
SPM4015T- 4R7M-CA	4.7	+/-20%	100	206.5 max	187.7	2.7	3.7	1.8

Note. Idc 1 : Based on the inductance change. (-30% Reduction from Nominal L Value)

Idc 2 : Based on the self temperature rise. (+40 deg typ.)

Operating Temperature Range: -40 °C ~ +125 °C (including self temperature rise)

Caution: Please contact our sales person when you consider organic solvent or aqueous cleaning.

Inductance vs. DC Superposition

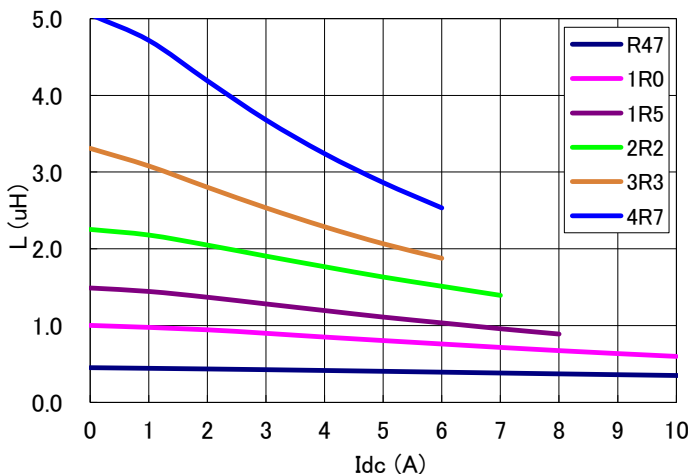

Recommended pad layout

