

THIS DRAWING IS UNPUBLISHED. RELEASED FOR PUBLICATION
 © COPYRIGHT BY TYCO ELECTRONICS CORPORATION. ALL INTERNATIONAL RIGHTS RESERVED.

LOC	DIST	REVISIONS					
FT	0	P	LTR	DESCRIPTION	DATE	DWN	APVD
		C		REVISED PER ECO-10-013614	11OCT10	HMR	CR

NOTES:
MATERIAL:
 HOUSING: THERMOPLASTIC, UL94V-0, BLACK.
 TERMINALS: BRIGHT TIN OVER COPPER ALLOY.
 SCREWS: 6-32, STEEL, ZINC PLATING W/ CLEAR CHROMATE.
MECHANICAL:
 PITCH: .375"
 OPERATING TEMP.: 105°C MAX
ELECTRICAL:
 RATED CURRENT: 20A.
 OPERATING VOLTAGE: 300V.
 WIRE RANGE: 12-22 AWG.

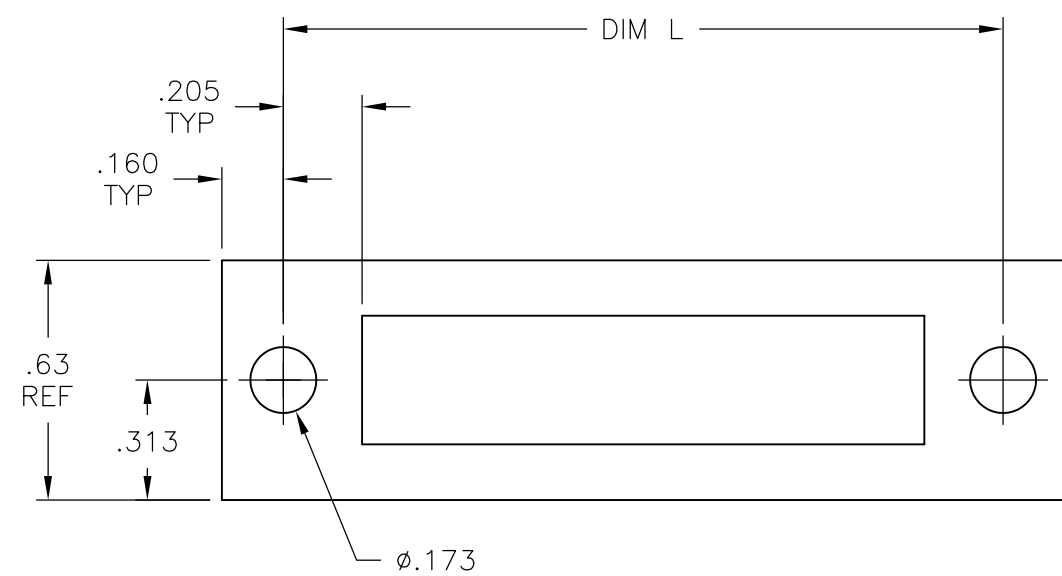
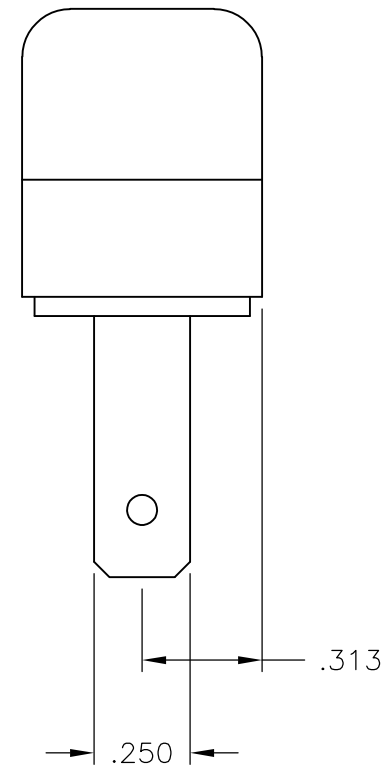
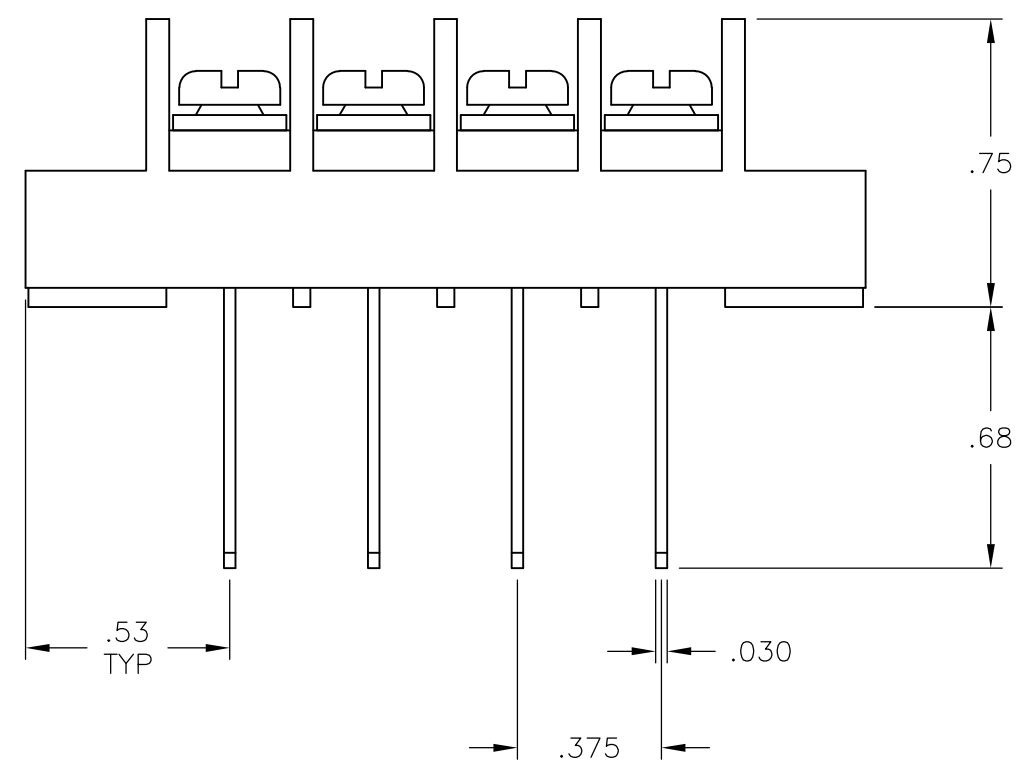
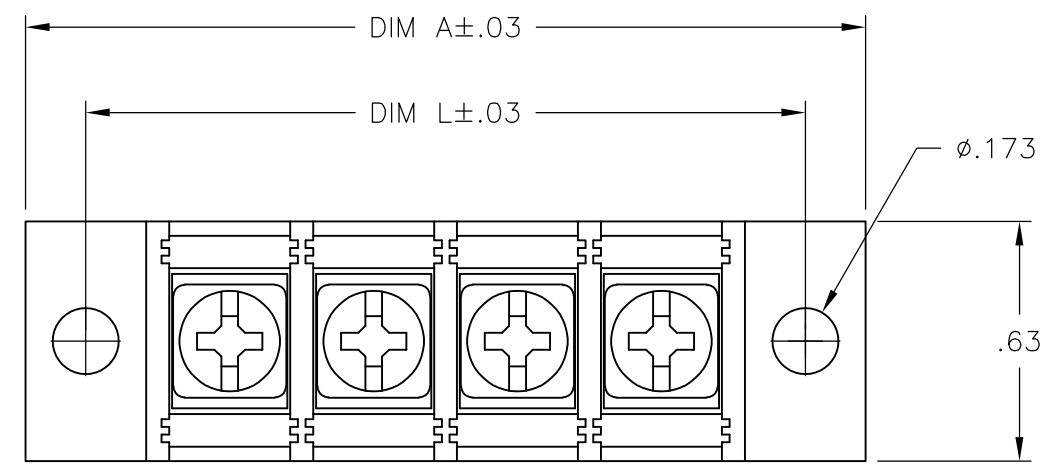

RECOMMENDED PANEL LAYOUT

DIM. L	DIM. A	NO. OF POS.	CATALOG NUMBER	TYCO PART NO.
9.000	9.314	23	JC6-Q208-23	2-1546842-3
8.625	8.939	22	JC6-Q208-22	2-1546842-2
8.250	8.564	21	JC6-Q208-21	2-1546842-1
7.875	8.189	20	JC6-Q208-20	2-1546842-0
7.500	7.814	19	JC6-Q208-19	1-1546842-9
7.125	7.439	18	JC6-Q208-18	1-1546842-8
6.750	7.064	17	JC6-Q208-17	1-1546842-7
6.375	6.689	16	JC6-Q208-16	1-1546842-6
6.000	6.314	15	JC6-Q208-15	1-1546842-5
5.625	5.939	14	JC6-Q208-14	1-1546842-4
5.250	5.564	13	JC6-Q208-13	1-1546842-3
4.875	5.189	12	JC6-Q208-12	1-1546842-2
4.500	4.814	11	JC6-Q208-11	1-1546842-1
4.125	4.439	10	JC6-Q208-10	1-1546842-0
3.750	4.064	9	JC6-Q208-09	1546842-9
3.375	3.689	8	JC6-Q208-08	1546842-8
3.000	3.314	7	JC6-Q206-07	2-1546842-4
3.000	3.314	7	JC6-Q208-07	1546842-7
2.625	2.939	6	JC6-Q208-06	1546842-6
2.250	2.564	5	JC6-Q208-05	1546842-5
1.875	2.189	4	JC6-Q208-04	1546842-4
1.500	1.814	3	JC6-Q208-03	5-1437665-0
1.125	1.439	2	JC6-Q208-02	1546842-2

THIS DRAWING IS A CONTROLLED DOCUMENT.		DWN S. SCHLEGEL 6/3/04	Tyco Electronics Corporation Harrisburg, PA 17105-3608	
DIMENSIONS: INCHES		CHK S. YODER 6/3/04		
TOLERANCES UNLESS OTHERWISE SPECIFIED:		APVD S. YODER 6/3/04	NAME JC6-Q208-XX ASSEMBLY	
0 PLC ± - 1 PLC ± - 2 PLC ± .02 3 PLC ± .010 4 PLC ± - ANGLES ± 1		PRODUCT SPEC -	SIZE A2	
MATERIAL		APPLICATION SPEC -	CAGE CODE 00779	DRAWING NO 5-1437665-0
FINISH		WEIGHT -	RESTRICTED TO -	SCALE NTS
		CUSTOMER DRAWING	SHEET 1 of 1	REV C