	TYPE	PRODUCT SPECIFICATION		NUMBER	GS-12-279
	TITLE	Straddle mount type Power edge connector			PAGE
				AUTHORIZED BY	Hai-Ling Liu
				REVISION	F
				DATE	April 10,2015
				CLASSIFICATION	UNRESTRICTED

### 1.0 OBJECTIVE

This specification defines the performance, test, quality and reliability requirements of the Straddle mount Power edge Connector.

### 2.0 SCOPE

This specification is applicable to the termination characteristics of separable power edge card when mated to Straddle mount type receptacles.

### 3.0 GENERAL

This document is composed of the following sections:

<u>Paragraph</u>	<u>Title</u>
1.0	OBJECTIVE
2.0	SCOPE
3.0	GENERAL
4.0	APPLICABLE DOCUMENTS
5.0	REQUIREMENTS
5.1	Qualification
5.2	Material
5.3	Finish
5.4	Design and construction
5.5	Workmanship
5.5	Operating temperature range
6.0	ELECTRICAL CHARACTERISTICS
7.0	MECHANICAL CHARACTERISTICS
8.0	ENVIRONMENTAL CONDITIONS
9.0	QUALITY ASSURANCE PROVISIONS
9.1	Equipment Calibration
9.2	Inspection Conditions
9.3	Acceptance
9.4	Qualification Testing
9.5	Re-qualification Testing
10.0	Reference Documents
Table 1	Qualification Testing Matrix

	TYPE	PRODUCT SPECIFICATION		NUMBER	GS-12-279		
	TITLE	Straddle mount type Power edge connector		PAGE	2 of 11	REVISION	F
				AUTHORIZED BY	Hai-Ling Liu	DATE	April 10,2015
				CLASSIFICATION	UNRESTRICTED		

#### 4.0 APPLICABLE DOCUMENTS

##### 4.1 Specifications

4.1.1 Engineering Drawings 10034908

##### 4.2 Federal Specifications

4.2.1 MIL-STD-1344A: Test Methods for Electrical Connectors

##### 4.3 Other Standards and Specifications

4.3.1 UL 94 V-0: Flammability

4.3.2 EIA 364: Test Procedures for Electrical Connectors, Sockets and Coaxial Contacts

##### 4.4 FCI Specifications:

4.4.1 BUS-03-601: Current Rating/30°C Temperature Rise

4.4.2 BUS-03-404: Normal Force Measurement

4.4.3 BUS-19-002: Solderability test

#### 5.0 REQUIREMENTS

##### 5.1 Qualification

Connectors furnished under this specification shall be capable of meeting the qualification test requirements specified herein.

##### 5.2 Material

The material for each component shall be as specified herein or equivalent.

Power Contacts – High Conductivity Copper alloy

Receptacle Housing – Class filled, Nylon (High Temperature Nylon)

##### 5.3 Finish

Minimum 30 micro-inches Au on contact area, Minimum 100 micro-inches Matt pure Tin on solder tails, both over a minimum 50 micro-inches Ni.

##### 5.4 Design and Construction

Connectors shall be of the design, construction and physical dimensions specified on the applicable product drawings.

5.4.1 See drawing number 10034908 for test connector configurations.

##### 5.5 Workmanship includes freedom from blistering, cracks, discoloration, etc.

##### 5.6 Operating temperature range: -5 °C ~ 105 °C

	TYPE <b>PRODUCT SPECIFICATION</b>	NUMBER <b>GS-12-279</b>		
	TITLE <b>Straddle mount type Power edge connector</b>	PAGE 3 of 11	REVISION F	
		AUTHORIZED BY Hai-Ling Liu	DATE April 10,2015	
CLASSIFICATION <b>UNRESTRICTED</b>				

## 6.0 ELECTRICAL CHARACTERISTICS

- 6.1 Low Level Contact Resistance (LLCR) - The low level contact resistance shall not exceed 20 milliohm after environmental exposure when measured in accordance with EIA 364 TP 06. The following details shall apply:
- Test Voltage – 20 millivolts DC max open circuit.
  - Test Current - Not to exceed 100 milliamps.
- 6.2 Insulation Resistance - the insulation resistance of mated connectors shall not be less than 5,000 megohms for power contacts, and 500 megohms for signal initially and after environmental exposure when measured in accordance with EIA 364 TP21
- Test Voltage 500 volts DC
  - Electrification time - 2 minutes
  - Points of Measurement - Between adjacent Contacts
- 6.3 Dielectric Withstanding Voltage - There shall be no evidence of arc-over, insulation breakdown, or excessive leakage current (>1 Milliampere ) when mated connectors are tested in accordance with EIA 364 TP 20. The following details apply:
- Test Voltage – 1000 Volts, AC.
  - Test Duration – 60 seconds.
  - Test Condition – (760 Torr – sea level).
  - Points of measurement – between adjacent contacts
- 6.4 Current Rating - The temperature rise above ambient shall not exceed 30<sup>0</sup> C at any point in the system when one pair of blade module contacts are powered to 20 amperes. One blade module are constituted by 3 pins. The temperature rise above ambient shall not exceed 30<sup>0</sup> C at any point in the system when the other pair contacts are powered at 7.0 amperes.(refer to para. 10.0 layout drawing)  
The following details shall apply:
- Ambient conditions - Still air at 25°C
  - Reference – FCI Test Specification BUS-03-601.

## 7.0 MECHANICAL CHARACTERISTICS

- 7.1 Mating/Unmating Force - The force to mate a receptacle connector and PCB header shall not exceed 8.0 Kgf. The unmating force shall not be less than 1.2 Kgf.  
The following details shall apply:
- Cross Head Speed - 1 inch per minute
  - Lubrication - None
  - Utilize free floating fixtures
  - Reference EIA 364-13
  - Test PCB thickness is 1.57+/-0.13mm (inclusive of two pads).

	TYPE <b>PRODUCT SPECIFICATION</b>	NUMBER <b>GS-12-279</b>		
	TITLE <b>Straddle mount type Power edge connector</b>	PAGE 4 of 11	REVISION F	
		AUTHORIZED BY Hai-Ling Liu	DATE April 10,2015	
		CLASSIFICATION <b>UNRESTRICTED</b>		

- 7.2 Normal Force - The contact normal force shall not be less than 150 grams per contact when tested in accordance with FCI Test Specification BUS-03-404.
- 7.3 Contact Retention - Individual power contacts shall withstand an axial retention load of 300 gf minimum per pin to seat further into housing.
- Rate of 25.4 mm/minute without dislodging from the housing cavity.
  - Test PCB thickness is 1.57+/-0.13mm (inclusive of two pads).
  - Test pin numbers: 1, 10, 19, 20, 29, 38
- 7.4 Solder tails Insertion- the insertion force of Straddle type solder and mounting PCB shall not exceed 10 Kgf per all solder tails to insert into mounting PCB.  
The following details shall apply:
- Rate of 25.4mm/minute with Mounting PCB.
  - Test PCB thickness is 1.57+/-0.13mm (inclusive of two pads).
- 7.5 Reseating  
The connector pair needs to undergo 3 manual plug/unplug cycles.
- Sample Size – Dependent upon current test group, refer to specific sample sizes.
  - Failure Criteria - No evidence of physical damage.
  - No lubrication to be used during cycling.
- 7.6 Vibration Sinusoidal - EIA 364 TP 28
- Test procedure: Test Condition – VII, test condition letter D.
  - Mounting – To eliminate relative motion between the contacts, both mating halves should be rigidly fixed.
  - Duration – 1 hour per axis / 3 axis.
  - Failure criteria - No evidence of physical damage. No interruptions > 1.0 micro-second.
- 7.7 Mechanical Shock - EIA 364-27
- Condition A (50G, 11 millisecond half sine wave )
  - Shocks - 3 shocks in both directions along each of three orthogonal axes (18 total)
  - Mounting - rigidly mount assemblies
  - No discontinuities of greater than 1.0 micro-second
- 7.8 Durability - Standard laboratory procedure as applicable to the specific product EIA-364-09
- Number of Cycles - 200
  - Cycling rate – 25.4mm per minute
- 7.9 Durability (preconditioning) EIA-364-09

The intent of this test is encompassed in latest version of EIA-364-09.

- Number of Cycles - 5
- Sample Size – Dependent upon current test group, refer to specific sample sizes.
- Failure Criteria – No evidence of physical damage.

	TYPE <b>PRODUCT SPECIFICATION</b>	NUMBER <b>GS-12-279</b>		
	TITLE <b>Straddle mount type Power edge connector</b>	PAGE 5 of 11	REVISION F	
		AUTHORIZED BY Hai-Ling Liu	DATE April 10,2015	
		CLASSIFICATION <b>UNRESTRICTED</b>		

- d. No lubrication to be used during cycling.
- e. Cycling to be performed manually unless otherwise specified.
- f. Cycling rate - 500 cycles per hour

## 8.0 ENVIRONMENTAL CONDITIONS

After exposure to the following environmental conditions in accordance with the specified test procedure and / or details, the product shall show no physical damage and shall meet the applicable electrical and mechanical requirements of paragraphs 6.0 and 7.0 as detailed in Table 1 test sequences. Unless otherwise specified, assemblies shall be mated during exposure.

### 8.1 Thermal Shock - EIA 364 TP 32

- a. Test condition - I, 10 cycles
- b. Temperature Range - -20 to +80°C
- c. Time at Each Temperature - 30 minutes minimum
- d. Transfer Time - 5 minutes, maximum

### 8.2 Cycling Temperature and Humidity - EIA 364 TP 31, Method II

- a. Test condition A
- b. Relative Humidity - 95%
- c. Temperature +40°C
- d. Test Duration – 96 hours

### 8.3 High Temperature Life, EIA 364 TP 17

- a. Test condition 4
- b. Test time condition B - 250 Hours
- c. Temperature 105°C
- d. Pre-condition - Perform number of durability cycles specified for product

### 8.4 High Temperature Life (preconditioning)

Test per EIA 364-1000.01 Table 9. Duration of 120 hours at temperature 105°C to pertaining of 65°C for 10 years.

### 8.5 Mixed Flowing Gas (MFG) – EIA 364-65

- a. Class – IIA
- b. Duration – 10 days
- c. Test per EIA 364-1000.01 Table 4, Note –For 1 piece connector.

### 8.6 Solderability – BUS-19-002/B

- a. Steam aging - 4 hours
- b. PCB termination area was evaluated and meets the requirements of BUS-19-002.

	TYPE <b>PRODUCT SPECIFICATION</b>	NUMBER <b>GS-12-279</b>		
	TITLE <b>Straddle mount type Power edge connector</b>	PAGE 6 of 11	REVISION F	
		AUTHORIZED BY Hai-Ling Liu	DATE April 10,2015	
CLASSIFICATION <b>UNRESTRICTED</b>				

## 9.0 QUALITY ASSURANCE PROVISIONS

### 9.1 Equipment Calibration

All test equipment and inspection facilities used in the performance of any test shall be maintained in a calibration system in accordance with QS 9000

### 9.2 Inspection conditions

Unless otherwise specified, all inspections shall be performed under the following conditions:

- a. Temperature: 25 +/- 5°C
- b. Relative humidity: 30 to 60%
- c. Barometric Pressure: Local ambient

### 9.3 Acceptance

9.4.1 Electrical and Mechanical requirements shall be as indicated in Paragraphs 6.0 and 7.0 using test data and appropriate statistical techniques.

9.4.2 Failures attributed to equipment, test setup or operator error shall not disqualify the product.

### 9.4 Qualification Testing

Qualification testing shall be performed on sample units predicted with equipment and procedures normally used in production. Test sequence is as shown in Table 1.

### 9.5 Re-qualification Testing

If any of the following conditions occur, the responsible product engineer shall initiate re-qualification testing consisting of the applicable parts of the test matrix, Table 1.

- a. A significant design change is made to the existing product that impacts the product form, fit or function. Examples of significant changes shall include, but not be limited to, changes in the plating material composition or thickness, contact force or contact surface geometry, insulator design, contact base material or contact lubrication requirements.
- b. A significant event occurs during production or end use requiring corrective action to be taken relative to the product design or manufacturing process.
- c. A significant change is made to the manufacturing process that impacts the product form, fit or function.

## 10.0 Reference Documents

	TYPE <b>PRODUCT SPECIFICATION</b>	NUMBER <b>GS-12-279</b>		
	TITLE <b>Straddle mount type Power edge connector</b>	PAGE 7 of 11	REVISION F	
		AUTHORIZED BY Hai-Ling Liu	DATE April 10,2015	
		CLASSIFICATION <b>UNRESTRICTED</b>		

a. product drawing and pin assignment (refer to the customer drawing respectively for each P/N):

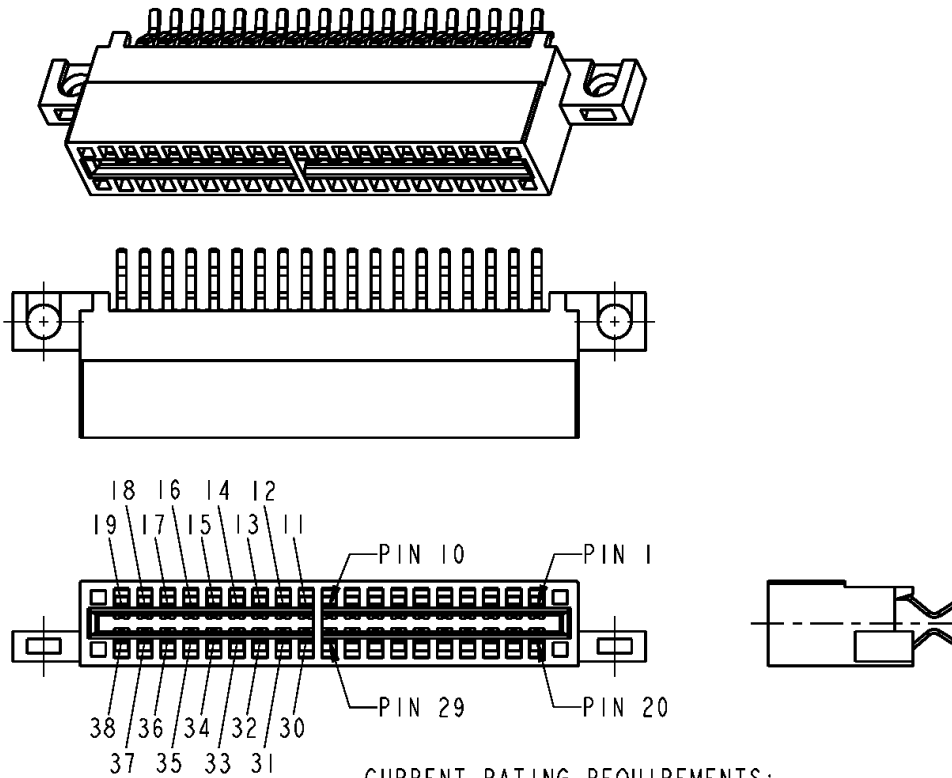

CURRENT RATING REQUIREMENTS:  
 1, 7A =PIN 1~10, PIN 20~29  
 2, 20A =6 BLADE MODULES  
 BLADE A: PIN 11~13  
 BLADE B: PIN 14~16  
 BLADE C: PIN 17~19  
 BLADE D: PIN 30~32  
 BLADE E: PIN 33~35  
 BLADE F: PIN 36~38

	TYPE <b>PRODUCT SPECIFICATION</b>	NUMBER <b>GS-12-279</b>		
	TITLE <b>Straddle mount type Power edge connector</b>	PAGE 8 of 11	REVISION F	
		AUTHORIZED BY Hai-Ling Liu	DATE April 10,2015	
		CLASSIFICATION <b>UNRESTRICTED</b>		

b. Mating board side PCB layout (refer to the customer drawing respectively for each P/N)

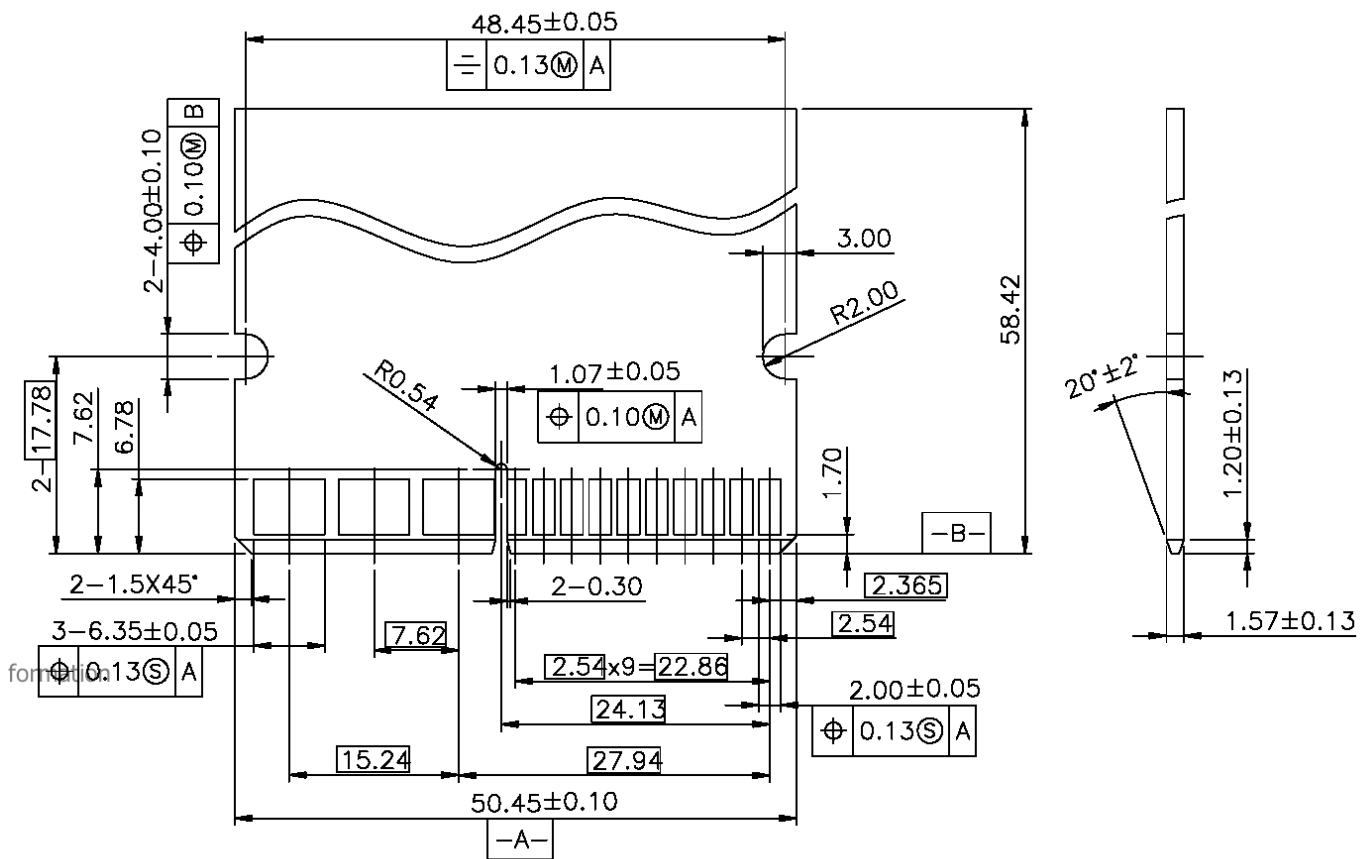

## RECOMMENDED MATING BOARD EDGE CONFIGURATION



	TYPE <b>PRODUCT SPECIFICATION</b>	NUMBER <b>GS-12-279</b>		
	TITLE <b>Straddle mount type Power edge connector</b>	PAGE 9 of 11	REVISION F	
		AUTHORIZED BY Hai-Ling Liu	DATE April 10,2015	
		CLASSIFICATION <b>UNRESTRICTED</b>		

c. Solder tail side PCB layout (refer to the customer drawing respectively for each P/N)

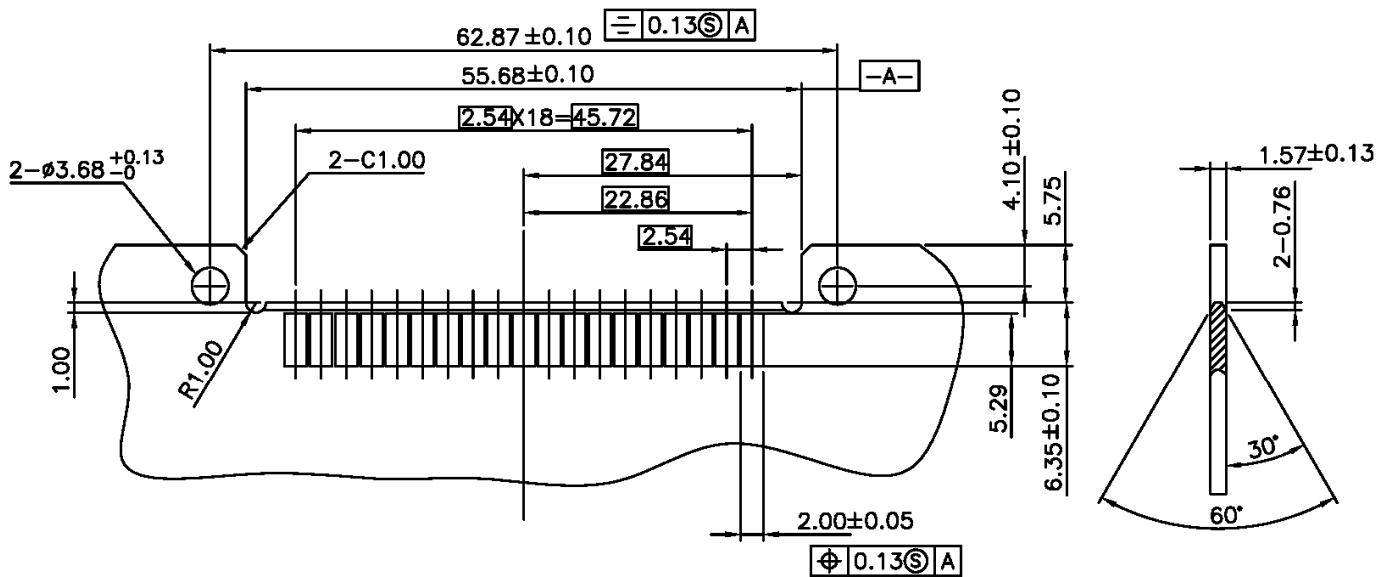

RECOMMENDED PC BOARD LAYOUT  
FOR CONNECTOR SOLDER TAILS

	TYPE	<b>PRODUCT SPECIFICATION</b>		NUMBER	<b>GS-12-279</b>				
	TITLE	Straddle mount type Power edge connector			PAGE	10 of 11		REVISION	F
				AUTHORIZED BY	Hai-Ling Liu		DATE	April 10,2015	
				CLASSIFICATION	<b>UNRESTRICTED</b>				

**Test Sequence Table 1**

Test Items	Para.	Test Group							
		1	2	3	4	5	6	7	8
		Test Sequence							
Examination of Product	5.5	1, 7	1, 11	1, 9	1, 10	1, 8	1, 8	1, 3	1, 6
Contact Resistance Low Level	6.1	2	2	2	2				
		4	5	6	5	3			
		6	8	8	7	7			
			10	8	9				
Insulation Resistance	6.2		7				2, 6		
Dielectric Withstanding Voltage	6.3						3, 7		
Current Rating	6.4							2	
Mating/Unmating Force	7.1					2, 4, 6			
Normal Force	7.2								2
Contact Retention	7.3								4
Solder tails Insertion	7.4								3
Reseating	7.5	5	9		8				
Vibration	7.6			5					
Mechanical Shock	7.7			7					
Durability	7.8					5			
Durability (Preconditioning)	7.9		3	3	3				
Thermal Shock	8.1		4				4		
Cycling Temperature and Humidity	8.2		6				5		
Hi Temperature Life	8.3	3							
Hi Temperature Life (Preconditioning)	8.4			4	4				
Mixed Flowing Gas	8.5				6				
Solderability	8.6								5
Samples quantity		5	5	5	5	5	3	5	5

	TYPE	<b>PRODUCT SPECIFICATION</b>		NUMBER	<b>GS-12-279</b>	
	TITLE	<b>Straddle mount type Power edge connector</b>			PAGE	<b>11 of 11</b>
					AUTHORIZED BY	<b>Hai-Ling Liu</b>
					REVISION	<b>F</b>
					DATE	<b>April 10,2015</b>
					CLASSIFICATION	<b>UNRESTRICTED</b>

**REVISION RECORD**

<u>REV</u>	<u>PAGE</u>	<u>DESCRIPTION</u>	<u>EC#</u>	<u>DATE</u>
A	ALL	Guardianship Transfer	T04-0314	Jul 13, 04
B	ALL	New Released	DG04-0051	Jul 26, 04
C	3	Current rating changed into 7A from 5A	DG06-0197	May 25, 06
D	2	Add Para 5.6 operating temperature range	DG06-0220	Jun 05, 06
E	3,4	Change PCB thickness tolerance in Para 7.0	DG06-0271	Jul 04, 06
	7,8,9	Update 3 views shown in Para 10.0 as per dwg		
F	ALL	Change classification from confidential to unrestricted	ELX-DG-20683-1	Apr 10,14