

1. General description

Planar passivated Temperature and Overload Protected Triac with high commutation performance in a SOT78 (TO-220AB) plastic package. This TOPTriac conveniently self protects by turning off in the event of excessive temperature. It is triggered negatively using continuous DC or current pulses. TOPTriac is ideal for applications where heatsinking is limited. TOPTriac is safe to use in short-term overload under normal duty cycle conditions. TOPTriac gives the additional assurance that it will self-protect, if pushed to thermal overload, under abnormal duty cycle or fault conditions.

2. Features and benefits

- Over-temperature self-protection function
- Eliminates risk of overload failure due to limited heatsinking
- Pin compatible with standard triacs
- Exclusive negative gate triggering
- Full cycle AC conduction
- Hi-Com technology for maximum immunity to false triggering
- High immunity to false turn-on by dV/dt
- High minimum IGT for guaranteed immunity to gate noise
- Planar passivated for voltage ruggedness and reliability

3. Applications

- Any circuit where protection against overload and/or over temperature is required
- Motor controls and starters – e.g. refrigeration compressors
- High power density motors – e.g. vacuum cleaners, window blinds, food processors
- Heating and cooking appliances
- Water boilers

4. Quick reference data

Table 1. Quick reference data

Symbol	Parameter	Conditions	Min	Typ	Max	Unit
V_{DRM}	repetitive peak off-state voltage		-	-	800	V
$I_{T(RMS)}$	RMS on-state current	full sine wave; $T_{mb} \leq 101\text{ °C}$; Fig. 1 ; Fig. 2 ; Fig. 3	-	-	16	A
I_{TSM}	non-repetitive peak on-state current	full sine wave; $T_{j(\text{init})} = 25\text{ °C}$; $t_p = 20\text{ ms}$; Fig. 4 ; Fig. 5	-	-	140	A
T_j	junction temperature	conducting mode	-	-	125	°C
		self-protection mode			150	°C

Symbol	Parameter	Conditions	Min	Typ	Max	Unit
Static characteristics						
I _{GT}	gate trigger current	V _D = 12 V; I _T = 100 mA; LD+ G-; T _j = 25 °C; Fig. 7	5	-	35	mA
		V _D = 12 V; I _T = 100 mA; LD- G-; T _j = 25 °C; Fig. 7	5	-	35	mA
I _H	holding current	V _D = 12 V; T _j = 25 °C; Fig. 9	-	-	35	mA
V _T	on-state voltage	I _T = 18 A; T _j = 25 °C; Fig. 10	-	1.3	1.5	V
Dynamic characteristics						
dV _D /dt	rate of rise of off-state voltage	V _{DM} = 536 V; T _j = 125 °C; (V _{DM} = 67% of V _{DRM}); exponential waveform; gate open circuit	500	-	-	V/μs
dI _{com} /dt	rate of change of commutating current	V _D = 400 V; I _{T(RMS)} = 16 A; dV _{com} /dt = 20 V/μs; (snubberless condition); gate open circuit	15	-	-	A/ms

5. Pinning information

Table 2. Pinning information

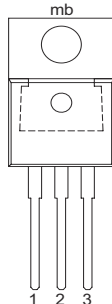
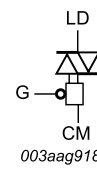
Pin	Symbol	Description	Simplified outline	Graphic symbol
1	CM	common		
2	LD	load		
3	G	gate		
mb	LD	mounting base; load		

6. Ordering information

Table 3. Ordering information

Type number	Package		Version
	Name	Description	
TOPT16-800C0	TO-220AB	Plastic single-ended package; heatsink mounted; 1 mounting hole; 3 leads TO-220AB	SOT78

7. Marking

Table 4. Marking codes

Type number	Marking Code
TOPT16-800C0	TOPT16-800C0

8. Limiting values

Table 5. Limiting values

In accordance with the Absolute Maximum Rating System (IEC 60134).

Symbol	Parameter	Conditions	Min	Max	Unit
V_{DRM}	repetitive peak off-state voltage		-	800	V
$I_{T(RMS)}$	RMS on-state current	full sine wave; $T_{mb} \leq 101\text{ °C}$; Fig. 1 ; Fig. 2 ; Fig. 3	-	16	A
I_{TSM}	non-repetitive peak on-state current	full sine wave; $T_{j(\text{init})} = 25\text{ °C}$; $t_p = 20\text{ ms}$; Fig 4 ; Fig 5	-	140	A
		full sine wave; $T_{j(\text{init})} = 25\text{ °C}$; $t_p = 16.7\text{ ms}$	-	150	A
I^2t	I^2t for fusing	$t_p = 10\text{ ms}$; sine-wave pulse	-	98	A^2s
dI_T/dt	rate of rise of on-state current	$I_G = 70\text{ mA}$	-	100	$A/\mu s$
I_{GM}	peak gate current		-	2	A
P_{GM}	peak gate power		-	5	W
$P_{G(AV)}$	average gate power	over any 20 ms period	-	0.5	W
T_{stg}	storage temperature		-40	150	$^{\circ}C$
T_j	junction temperature	conducting mode	-	125	$^{\circ}C$
		self-protection mode	-	150	$^{\circ}C$

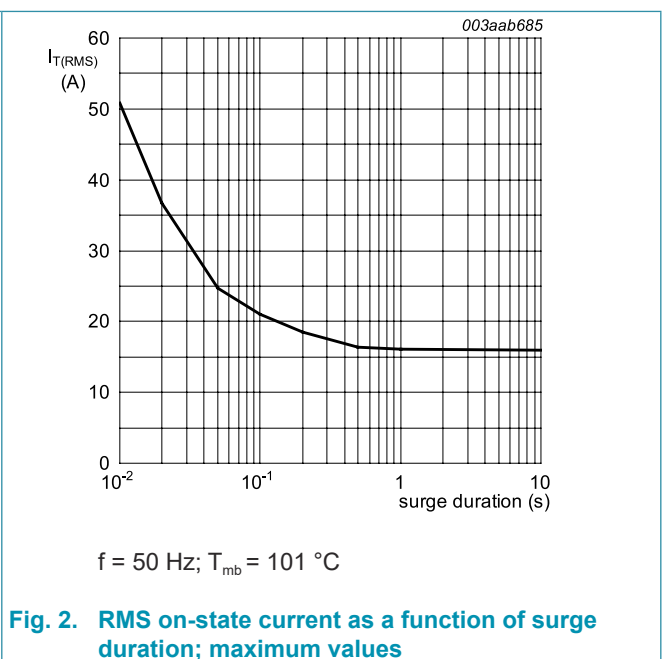
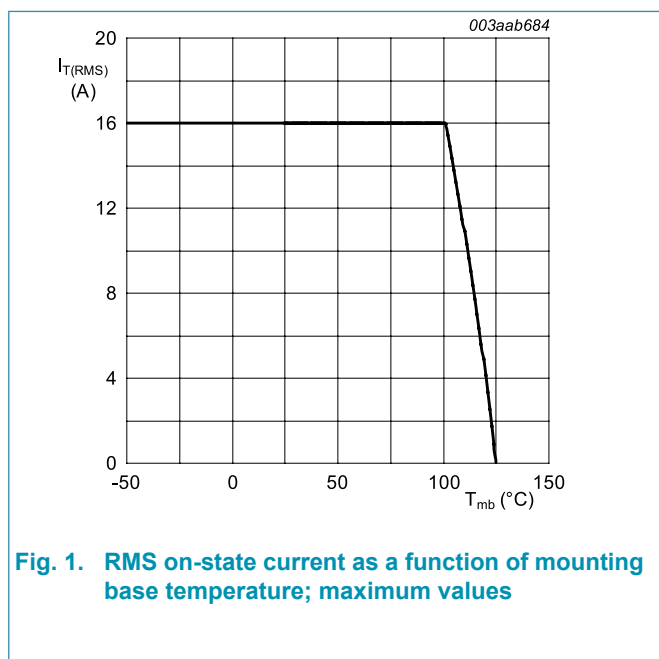

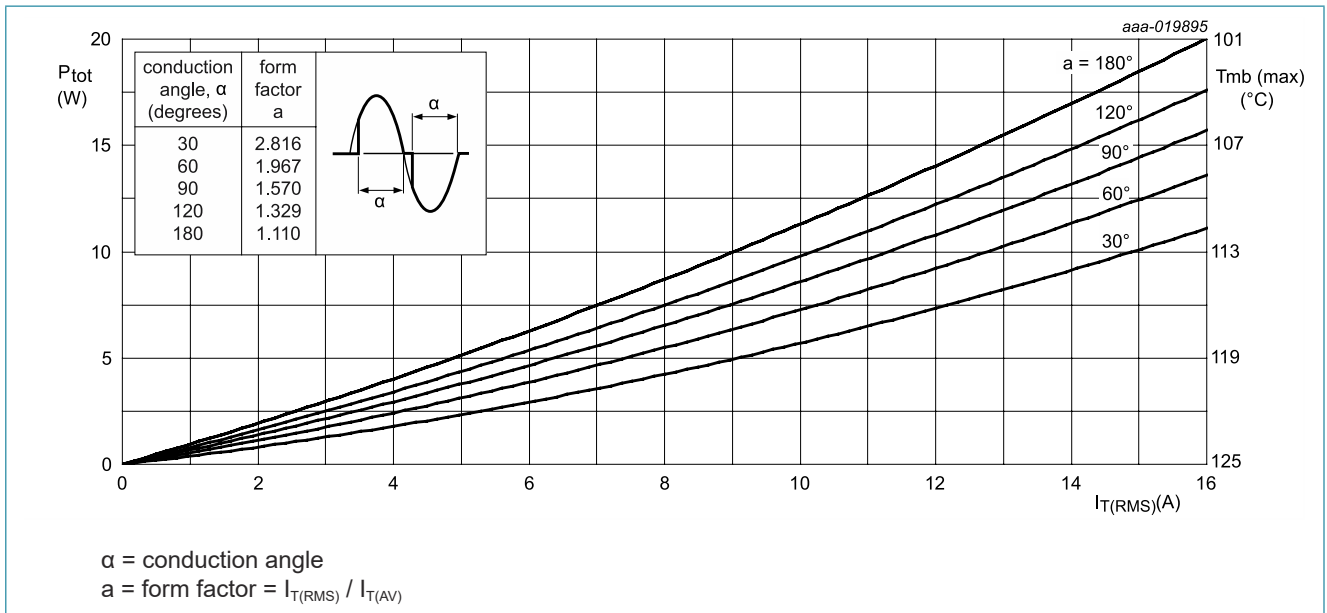

Fig. 3. Total power dissipation as a function of RMS on-state current; maximum values

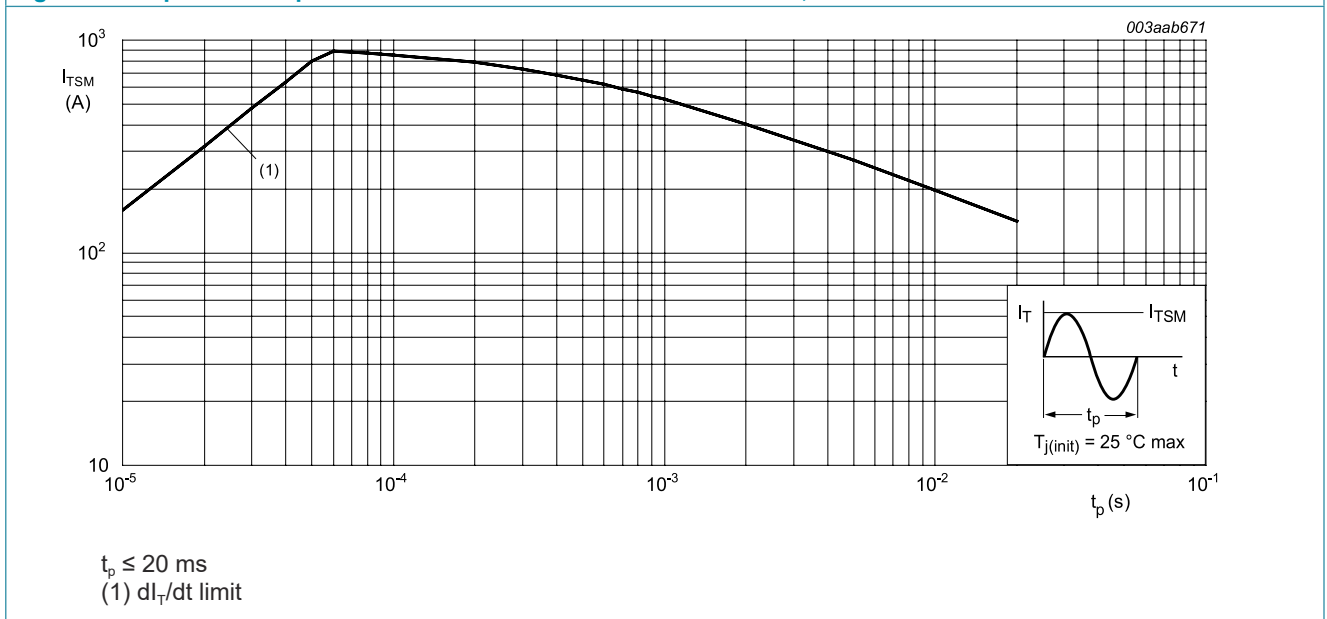
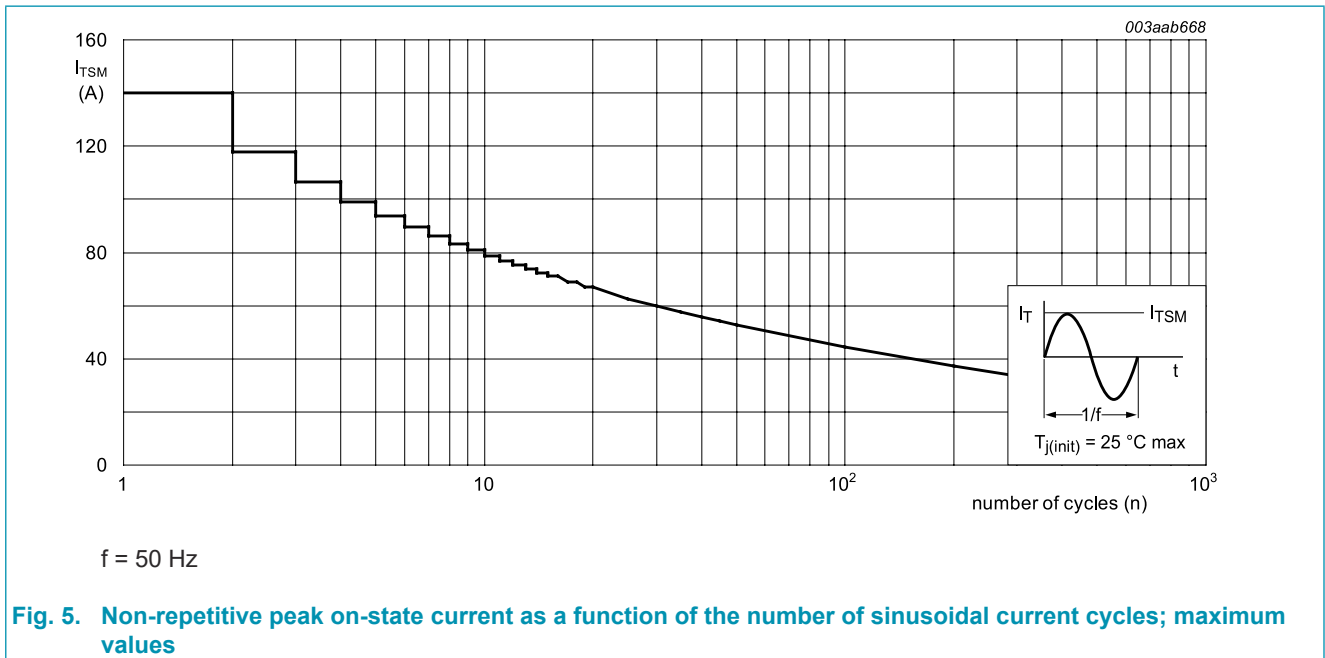

Fig. 4. Non-repetitive peak on-state current as a function of pulse width; maximum values



9. Thermal characteristics

Table 6. Thermal characteristics

Symbol	Parameter	Conditions	Min	Typ	Max	Unit
$R_{th(j-mb)}$	thermal resistance from junction to mounting base	full cycle; Fig. 6	-	-	1.2	K/W
$R_{th(j-a)}$	thermal resistance from junction to ambient free air	in free air	-	60	-	K/W

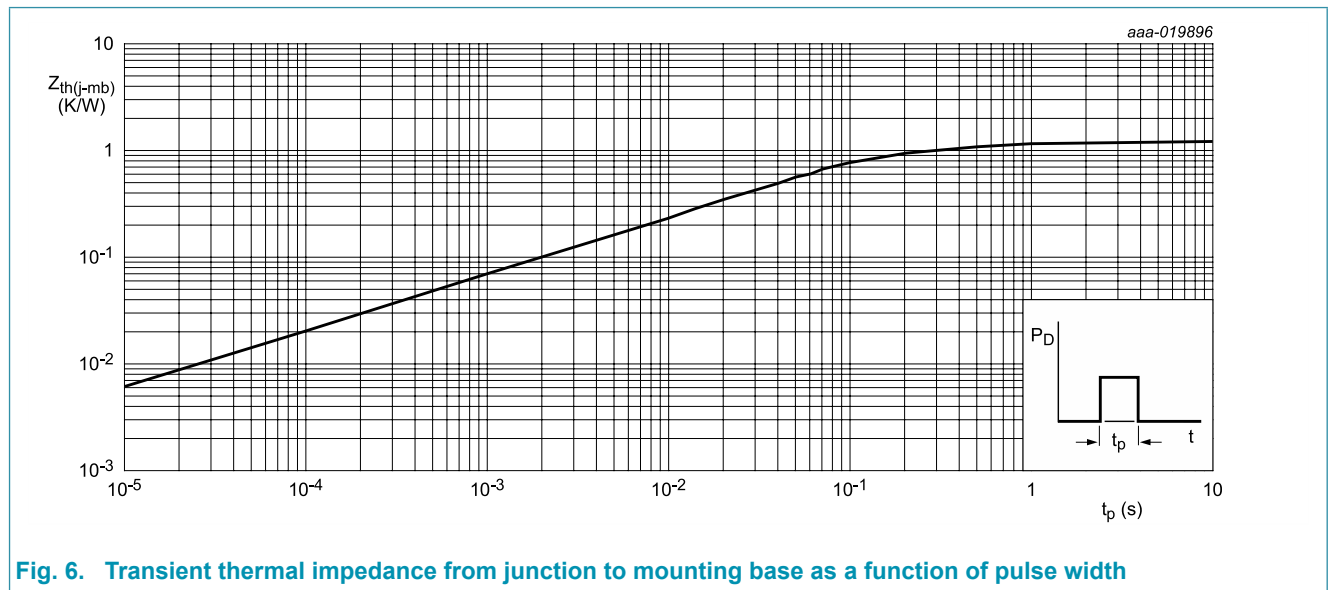
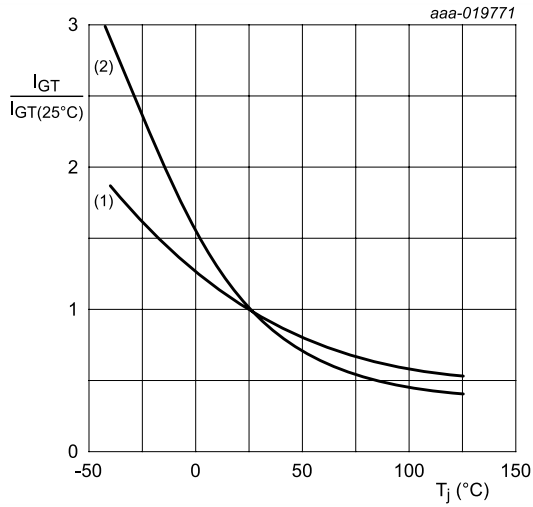

Fig. 6. Transient thermal impedance from junction to mounting base as a function of pulse width

10. Characteristics

Table 7. Characteristics

Symbol	Parameter	Conditions	Min	Typ	Max	Unit
Static characteristics						
I_{GT}	gate trigger current	$V_D = 12\text{ V}$; $I_T = 100\text{ mA}$; LD+ G-; $T_J = 25\text{ °C}$; Fig. 7	5	-	35	mA
		$V_D = 12\text{ V}$; $I_T = 100\text{ mA}$; LD- G-; $T_J = 25\text{ °C}$; Fig. 7	5	-	35	mA
I_L	latching current	$V_D = 12\text{ V}$; $I_G = 100\text{ mA}$; LD+ G-; $T_J = 25\text{ °C}$; Fig. 8	-	-	60	mA
		$V_D = 12\text{ V}$; $I_G = 100\text{ mA}$; LD- G-; $T_J = 25\text{ °C}$; Fig. 8	-	-	50	mA
I_H	holding current	$V_D = 12\text{ V}$; $T_J = 25\text{ °C}$; Fig. 9	-	-	35	mA
V_T	on-state voltage	$I_T = 18\text{ A}$; $T_J = 25\text{ °C}$; Fig. 10	-	1.3	1.5	V
V_{GT}	gate trigger voltage	$V_D = 12\text{ V}$; $I_T = 100\text{ mA}$; $T_J = 25\text{ °C}$; Fig. 11	-	1.4	2.3	V
		$V_D = 400\text{ V}$; $I_T = 100\text{ mA}$; $T_J = 125\text{ °C}$; Fig. 11	0.5	-	-	V
I_D	off-state current	$V_D = 800\text{ V}$; $T_J = 125\text{ °C}$	-	0.1	0.5	mA
Dynamic characteristics						
dV_D/dt	rate of rise of off-state voltage	$V_{DM} = 536\text{ V}$; $T_J = 125\text{ °C}$; ($V_{DM} = 67\%$ of V_{DRM}); exponential waveform; gate open circuit	500	-	-	V/ μs
dI_{com}/dt	rate of change of commutating current	$V_D = 400\text{ V}$; $I_{T(RMS)} = 16\text{ A}$; $dV_{com}/dt = 20\text{ V}/\mu\text{s}$; (snubberless condition); gate open circuit;	15	-	-	A/ms
Over-temperature protection characteristics						
T_{trip}	trip junction temperature	see application information	125	-	150	°C
$V_{G(trip)}$	trip gate voltage	$I_G = 2\text{ mA}$; see application information	0.3	-	-	V
		$I_G = 50\text{ mA}$; see application information	-	-	0.9	V
Operating requirement for pulsed gate triggering						
$I_{G(bl)}$	gate bleed current	$T_J = 25\text{ °C}$; $V_G = V_{G(trip)}$; circuit-applied current requirement; see application information section	0.5	-	-	mA
		$T_J < 150\text{ °C}$; $V_G = V_{GT}$; circuit-applied current requirement; see application information section	-	-	2	mA



(1) LD+ G-
(2) LD- G-

Fig. 7. Normalized gate trigger current as a function of junction temperature

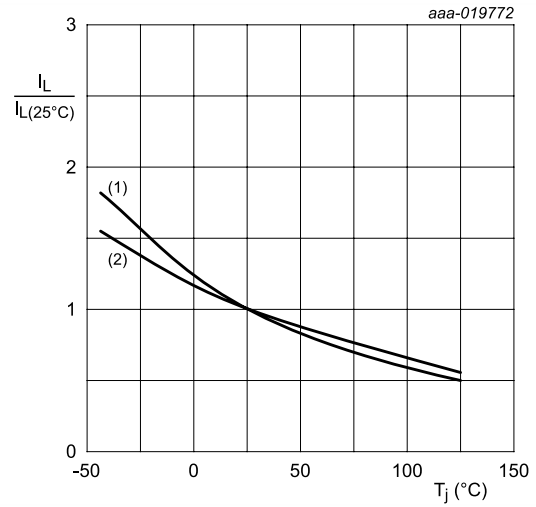

(1) LD+ G-
(2) LD- G-

Fig. 8. Normalized latching current as a function of junction temperature

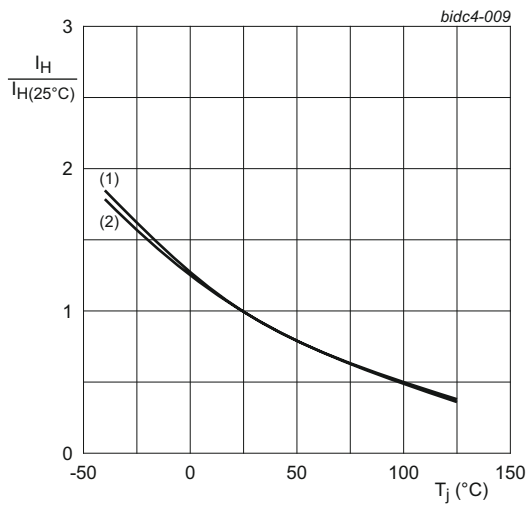

(1) LD+ G-
(2) LD- G-

Fig. 9. Normalized holding current as a function of junction temperature

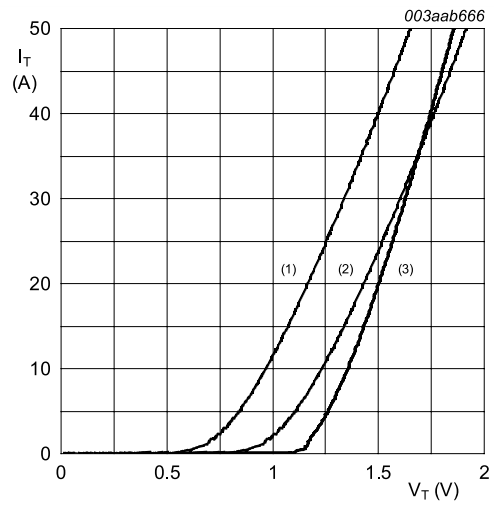

$V_o = 1.024 \text{ V}; R_s = 0.021 \Omega$
 (1) $T_j = 125 \text{ }^\circ\text{C}$; typical values
 (2) $T_j = 125 \text{ }^\circ\text{C}$; maximum values
 (3) $T_j = 25 \text{ }^\circ\text{C}$; maximum values

Fig. 10. On-state current as a function of on-state voltage

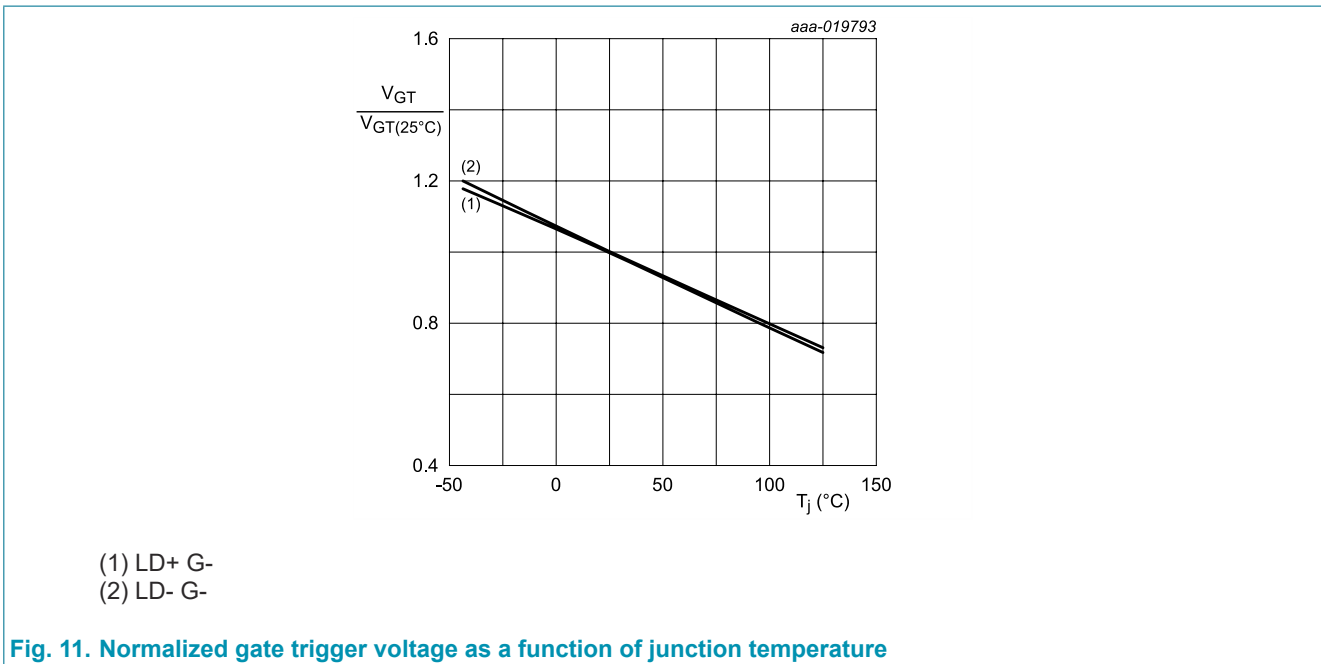

11. Application information

TOPTriac is a three terminal device that will plug into existing triac circuits. There are some unique features that must be understood to gain its full benefits.

11.1 The Gate terminal is also a Feedback terminal

TOPTriac can be triggered like any normal triac. In this conventional mode, the Gate acts as an input. However, the Gate can also be an output, since it provides voltage signatures that indicate the status of TopTriac. The controlling microcontroller can analyse the feedback and act upon it, according to the needs of the application.

11.2 Normal triggering

TOPTriac is triggered with negative gate current and may be triggered from 5 V logic or higher voltage supply with suitable series gate resistor. V_{GT} is higher than for standard triacs, so series gate resistors will be a little lower. For 35 mA I_{GT} and 5 V trigger voltage, the current-limiting resistance will typically be 82 Ω instead of 100 Ω for standard triacs.

DC gate triggering is the simplest method that automatically achieves safe latch-off after the over-temperature trip protection has been activated.

Alternatively, pulse triggering may be applied to the gate in combination with a low level bleed current ($I_{G(bl)}$), to sustain the trip condition after the over-temperature trip protection has been activated.

11.3 Over-temperature protection

If an overload current or insufficient cooling causes the junction temperature to rise above T_{trip} , TOPTriac will disable its gate drive to prevent further conduction before it loses control or becomes damaged. When the over-temperature trip is activated, the Gate-to-Common voltage V_{G-CM} reduces from the V_{GT} to the $V_{G(trip)}$ level (please refer to the V_{GT} and $V_{G(trip)}$ characteristics).

Continuous DC gate drive sustains continued safe latch-off even after TOPTriac temperature has dropped below T_{trip} . This allows a controlled reset by removing and reapplying gate drive after the fault condition has been removed.

Pulsed gate drive, which may be preferred for phase control or for efficiency reasons, is combined with a low level bleed current $I_{G(bl)}$ to sustain latch-off when the over-temperature trip is activated. (Please refer to the $I_{G(bl)}$ limiting values for the minimum and maximum allowable bleed current that may be applied during pulse triggering).

11.4 Resetting after over-temperature

As long as continuous gate current is applied after over-temperature trip, TOPTriac will remain deactivated even after the TOPTriac temperature has dropped below T_{trip} . This is the safest protection method that allows the removal of the fault condition before controlled reset is implemented.

The simplest reset is user-controlled, where TOPTriac will remain in the safe shutdown condition until gate drive or power is removed and reapplied.

Automatic reset will not require user intervention, but it may be 'unintelligent/dumb' open loop that does not involve a feedback stimulus, or 'intelligent/smart' closed loop that does respond to gate feedback.

User-controlled reset. The user removes and reapplies power to the application or presses a 'reset' button that momentarily removes the gate drive.

Open loop automatic reset. If there is a known or predictable overload condition in the application that may cause an occasional overheat, a periodic discontinuity may be programmed into the gate drive (e.g. at the end of the program stage, once per hour, day or week, depending on the application) that allows automatic reset. For DC gate drive, removal of the gate drive achieves reset. For pulsed gate drive, $I_{G(b)}$ must be removed and reapplied.

The previous two examples will work for applications that do not require immediate reaction to a fault condition, hence gate feedback monitoring is not needed.

Closed loop automatic reset. Applications where an immediate reaction to an over-temperature trip is needed will require monitoring of TOPTriac status. This is possible by monitoring V_{G-CM} while gate drive is being applied. During normal conduction, the higher level V_{GT} will be apparent with a square wave at mains frequency superimposed upon it. (The square wave on the gate results from the load current.) During the over-temperature trip condition, the lower level $V_{G(trip)}$ will be apparent and there will be no AC ripple because no load current is flowing. The difference can be detected by the microcontroller, which can take the appropriate action that has been programmed according to the needs of the application.

The following four figures show oscilloscope current and voltage waveforms for the four principal operating modes of TOPTriac: DC triggering, normal conduction and over-temperature tripped; pulse triggering, normal conduction and over-temperature tripped. The pulse triggering waveforms show phase control at the peak of the mains sine wave at half power setting.

Channel 1 shows gate current (20mA/div).

Channel 2 shows load current (5A/div).

Channel 3 shows gate voltage V_{G-CM} (1V/div).

Channel 4 shows load voltage V_{LD-CM} (200V/div).

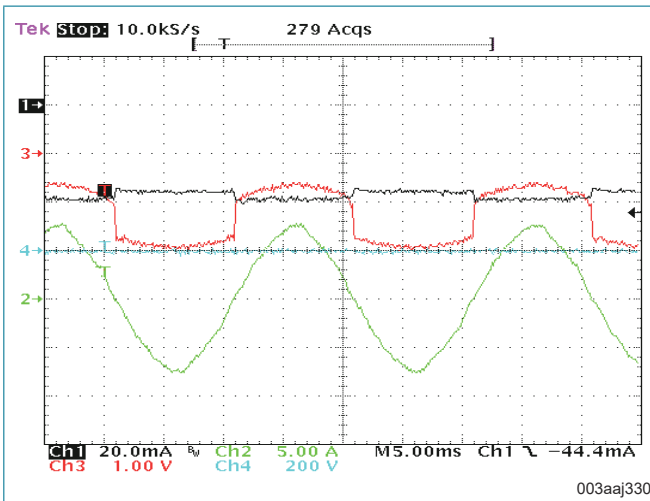

Fig. 12. DC triggering, normal conduction

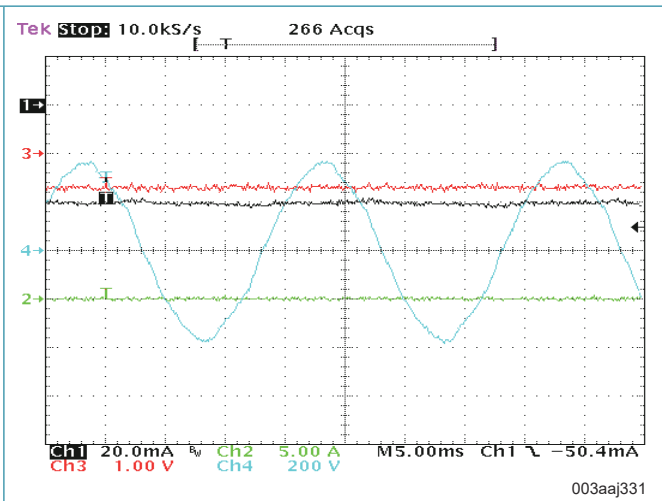

Fig. 13. DC triggering, over-temperature tripped

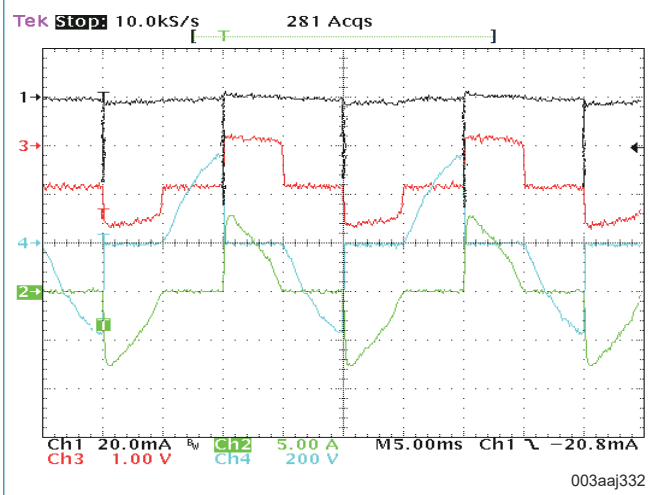

Fig. 14. Pulse triggering, normal conduction

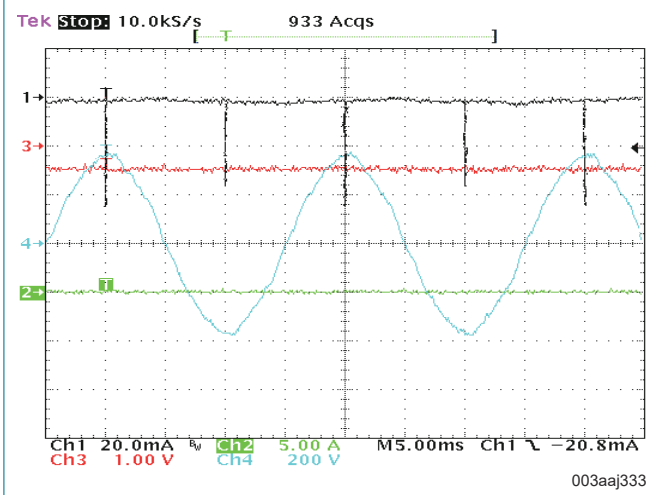

Fig. 15. Pulse triggering, over-temperature tripped

11.5 Important characteristics

T_{trip} is the junction temperature at which TOPTriac will disable itself. It will be above 125 °C and below 150 °C .

V_{GT} is the gate voltage characteristic during normal triggering. It is higher than for normal triacs. V_{GT} is used in the calculation of R_G to set the gate trigger current.

$V_{G(trip)}$ is the gate voltage characteristic when in the over-temperature trip condition. It is lower than V_{GT} . $V_{G(trip)}$ is used in the calculation of $R_{G(b)}$ to set the gate bleed current $I_{G(b)}$.

$I_{G(b)}$ is used during pulse triggering. It is the continuous DC bleed current that must flow out of the gate to achieve clean latch-off at the trip point and maintain this safe latch-off condition as TOPTriac cools down to ambient temperature.

The min $I_{G(b)}$ value is the minimum bleed current to sustain latch-off after cooling.

The max $I_{G(b1)}$ value is the maximum bleed current that will not trigger TOPTriac up to maximum trip temperature.

11.6 How to calculate the bleed resistor $R_{G(b1)}$

When pulse triggering it is critical that the bleed current is set correctly.

If $I_{G(b1)}$ is too low (lower than 0.5 mA), TOPTriac may not be able to provide reliable over-temperature protection during continuous fault conditions. Normal trip may be achieved at T_{trip} , but self-reset may occur as it cools, leading to on-off cycling. This constitutes a loss of control and should be avoided.

If $I_{G(b1)}$ is too high (higher than 2 mA), TOPTriac may trigger uncontrollably at elevated temperature that is below the trip temperature (This is another form of loss of control that must not be allowed). However, it will still self-protect as intended above trip temperature.

The following examples show how to calculate the minimum and maximum $R_{G(b1)}$. The chosen value should be approximately mid-way between the two extremes.

Example 1 (3.3 V logic supply)

Maximum $I_{G(b1)}$ is 2 mA. During normal conduction when $I_{G(b1)}$ must not be high enough to cause false triggering, V_{GT} applies and should be used in our calculations. Minimum V_{GT} @ $T_{j(max)}$ is 0.5 V.

Therefore minimum $R_{G(b1)}$:

$$R_{G(b1)} = (3.3 - 0.5) / 2 \text{ mA} = 1.4 \text{ k}\Omega$$

Minimum $I_{G(b1)}$ is 0.5 mA. When tripped, $V_{G(trip)}$ applies and should be used in our calculations. $I_{G(b1)}$ must remain high enough to maintain the trip condition, even when $V_{G(trip)}$ is at a maximum. Maximum $V_{G(trip)}$ is 0.9 V.

Therefore minimum $R_{G(b1)}$:

$$R_{G(b1)} = (3.3 - 0.9) / 0.5 \text{ mA} = 4.8 \text{ k}\Omega$$

Suggested $R_{G(b1)}$ is 3 k Ω .

Example 2 (5 V logic supply)

Min $R_{G(b1)}$:

$$R_{G(b1)} = (5 - 0.5) / 2 \text{ mA} = 2.25 \text{ k}\Omega$$

Max $R_{G(b1)}$:

$$R_{G(b1)} = (5 - 0.9) / 0.5 \text{ mA} = 8.2 \text{ k}\Omega$$

Suggested $R_{G(b1)}$ is 5.1 k Ω .

Example 3 (12 V auxiliary gate drive supply)

Min $R_{G(b1)}$:

$$R_{G(b1)} = (12 - 0.5) / 2 \text{ mA} = 5.75 \text{ k}\Omega$$

Max $R_{G(b1)}$:

$$R_{G(b1)} = (12 - 0.9) / 0.5 \text{ mA} = 22.2 \text{ k}\Omega$$

Suggested $R_{G(bl)}$ is 15 k Ω .

11.7 Application schematics

The following schematics show possible implementations of TOPTriac. Gate trigger current is from a 5 V minimum logic supply. It is possible to trigger from a 3.3 V microcontroller by using a transistor level shifter to a higher voltage gate drive power supply, which may be 5 V minimum or the 12 V supply that may already be available for other loads such as lighting, indication and sounders.

For **DC triggering**, reset is achieved by removing the gate drive at any time and reapplying it after TOPTriac temperature has dropped below T_{trip} .

For **pulse triggering**, reset is achieved by removing and reapplying the gate bleed current $I_{G(bl)}$ after TOPTriac temperature has dropped below T_{trip} .

$I_{G(bl)}$ is set by $R_{G(bl)}$. It is best derived directly from the low voltage microcontroller supply (up to 5V max) and will most likely be direct drive from the microcontroller output.

In all of the following circuits, gate trigger and gate bleed current are applied by logic zero drive from the microcontroller.

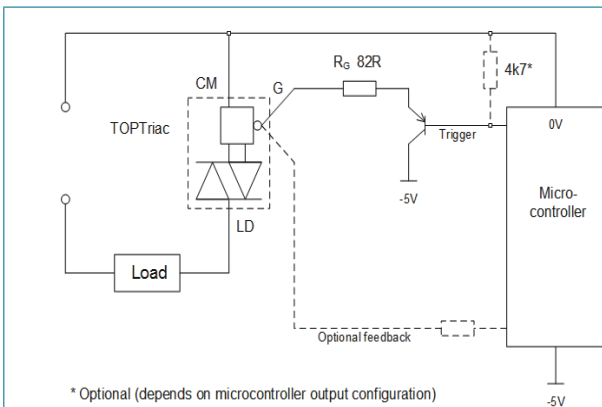

Fig. 16. DC triggering from 5 V microcontroller

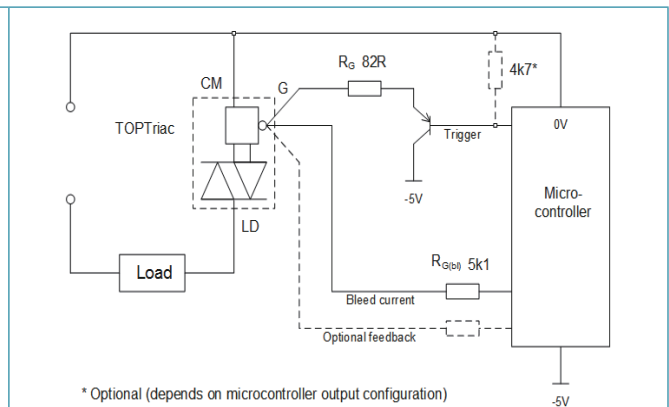

Fig. 17. Pulse triggering from 5 V microcontroller

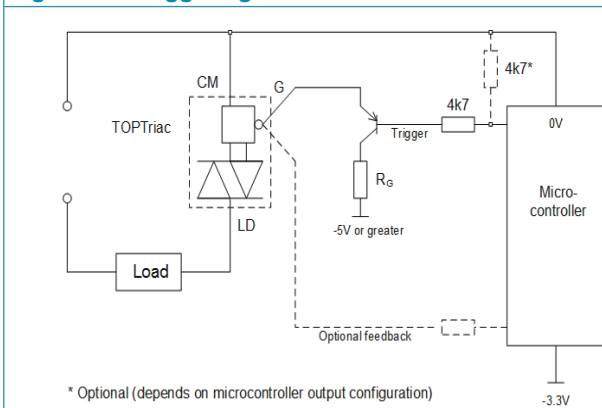

Fig. 18. DC triggering from 3.3 V microcontroller

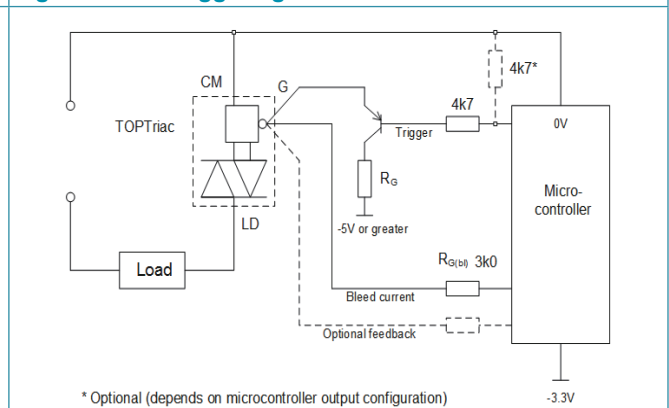
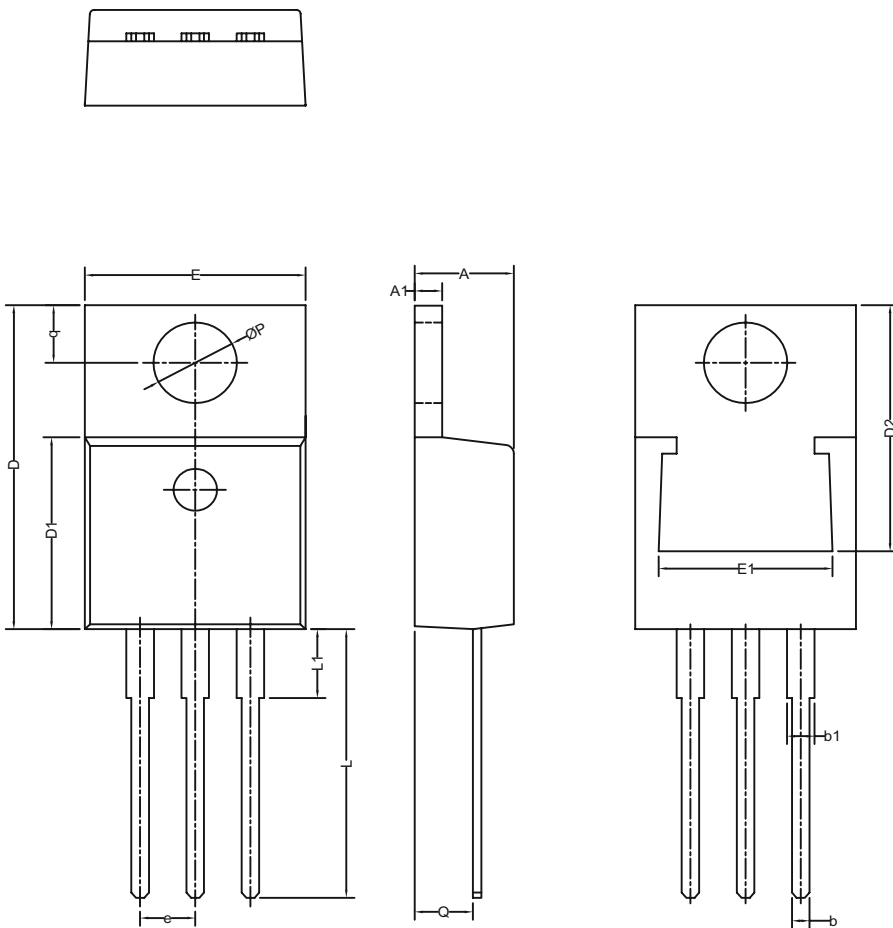

Fig. 19. Pulse triggering from 3.3 V microcontroller

12. Package outline

Plastic single-ended package;heatsink mounted;1 mounting hole; 3 leads TO-220AB

TO220



Unit	A	A1	b	b1	c	D	D1	D2	E	E1	e	L	L1	P	Q	q
min	4.10	1.22	0.60	1.00	0.34	15.15	9.05	11.40	9.70	6.86	2.54 (BSC)	12.70	2.79	3.50	2.20	2.60
max	4.70	1.40	0.90	1.60	0.70	16.00	9.25		10.36			15.00	3.90	3.88	2.79	3.00

13. Legal information

Data sheet status

Document status [1][2]	Product status [3]	Definition
Objective [short] data sheet	Development	This document contains data from the objective specification for product development.
Preliminary [short] data sheet	Qualification	This document contains data from the preliminary specification.
Product [short] data sheet	Production	This document contains the product specification.

- [1] Please consult the most recently issued document before initiating or completing a design.
- [2] The term 'short data sheet' is explained in section "Definitions".
- [3] The product status of device(s) described in this document may have changed since this document was published and may differ in case of multiple devices. The latest product status information is available on the Internet at URL <http://www.ween-semi.com>.

Definitions

Draft — The document is a draft version only. The content is still under internal review and subject to formal approval, which may result in modifications or additions. WeEn Semiconductors does not give any representations or warranties as to the accuracy or completeness of information included herein and shall have no liability for the consequences of use of such information.

Short data sheet — A short data sheet is an extract from a full data sheet with the same product type number(s) and title. A short data sheet is intended for quick reference only and should not be relied upon to contain detailed and full information. For detailed and full information see the relevant full data sheet, which is available on request via the local WeEn Semiconductors sales office. In case of any inconsistency or conflict with the short data sheet, the full data sheet shall prevail.

Product specification — The information and data provided in a Product data sheet shall define the specification of the product as agreed between WeEn Semiconductors and its customer, unless WeEn Semiconductors and customer have explicitly agreed otherwise in writing. In no event however, shall an agreement be valid in which the WeEn Semiconductors product is deemed to offer functions and qualities beyond those described in the Product data sheet.

Disclaimers

Limited warranty and liability — Information in this document is believed to be accurate and reliable. However, WeEn Semiconductors does not give any representations or warranties, expressed or implied, as to the accuracy or completeness of such information and shall have no liability for the consequences of use of such information. WeEn Semiconductors takes no responsibility for the content in this document if provided by an information source outside of WeEn Semiconductors.

In no event shall WeEn Semiconductors be liable for any indirect, incidental, punitive, special or consequential damages (including - without limitation - lost profits, lost savings, business interruption, costs related to the removal or replacement of any products or rework charges) whether or not such damages are based on tort (including negligence), warranty, breach of contract or any other legal theory.

Notwithstanding any damages that customer might incur for any reason whatsoever, WeEn Semiconductors' aggregate and cumulative liability towards customer for the products described herein shall be limited in accordance with the *Terms and conditions of commercial sale* of WeEn Semiconductors.

Right to make changes — WeEn Semiconductors reserves the right to make changes to information published in this document, including without limitation specifications and product descriptions, at any time and without notice. This document supersedes and replaces all information supplied prior to the publication hereof.

Suitability for use — WeEn Semiconductors products are not designed, authorized or warranted to be suitable for use in life support, life-critical or safety-critical systems or equipment, nor in applications where failure or malfunction of an WeEn Semiconductors product can reasonably be expected to result in personal injury, death or severe property or environmental damage. WeEn Semiconductors and its suppliers accept no liability for inclusion and/or use of WeEn Semiconductors products in such equipment or applications and therefore such inclusion and/or use is at the customer's own risk.

Quick reference data — The Quick reference data is an extract of the product data given in the Limiting values and Characteristics sections of this document, and as such is not complete, exhaustive or legally binding.

Applications — Applications that are described herein for any of these products are for illustrative purposes only. WeEn Semiconductors makes no representation or warranty that such applications will be suitable for the specified use without further testing or modification.

Customers are responsible for the design and operation of their applications and products using WeEn Semiconductors products, and WeEn Semiconductors accepts no liability for any assistance with applications or customer product design. It is customer's sole responsibility to determine whether the WeEn Semiconductors product is suitable and fit for the customer's applications and products planned, as well as for the planned application and use of customer's third party customer(s). Customers should provide appropriate design and operating safeguards to minimize the risks associated with their applications and products.

WeEn Semiconductors does not accept any liability related to any default, damage, costs or problem which is based on any weakness or default in the customer's applications or products, or the application or use by customer's third party customer(s). Customer is responsible for doing all necessary testing for the customer's applications and products using WeEn Semiconductors products in order to avoid a default of the applications and the products or of the application or use by customer's third party customer(s). WeEn does not accept any liability in this respect.

Limiting values — Stress above one or more limiting values (as defined in the Absolute Maximum Ratings System of IEC 60134) will cause permanent damage to the device. Limiting values are stress ratings only and (proper) operation of the device at these or any other conditions above those given in the Recommended operating conditions section (if present) or the Characteristics sections of this document is not warranted. Constant or repeated exposure to limiting values will permanently and irreversibly affect the quality and reliability of the device.

No offer to sell or license — Nothing in this document may be interpreted or construed as an offer to sell products that is open for acceptance or the grant, conveyance or implication of any license under any copyrights, patents or other industrial or intellectual property rights.

Export control — This document as well as the item(s) described herein may be subject to export control regulations. Export might require a prior authorization from competent authorities.

Non-automotive qualified products — Unless this data sheet expressly states that this specific WeEn Semiconductors product is automotive qualified, the product is not suitable for automotive use. It is neither qualified nor tested in accordance with automotive testing or application requirements. WeEn Semiconductors accepts no liability for inclusion and/or use of non-automotive qualified products in automotive equipment or applications.

In the event that customer uses the product for design-in and use in automotive applications to automotive specifications and standards, customer (a) shall use the product without WeEn Semiconductors' warranty of the product for such automotive applications, use and specifications, and (b) whenever customer uses the product for automotive applications beyond WeEn Semiconductors' specifications such use shall be solely at customer's own risk, and (c) customer fully indemnifies WeEn Semiconductors for any liability, damages or failed product claims resulting from customer design and use of the product for automotive applications beyond WeEn Semiconductors' standard warranty and WeEn Semiconductors' product specifications.

Translations — A non-English (translated) version of a document is for reference only. The English version shall prevail in case of any discrepancy between the translated and English versions.

Trademarks

Notice: All referenced brands, product names, service names and trademarks are the property of their respective owners.

14. Contents

1. General description.....	1
2. Features and benefits	1
3. Applications	1
4. Quick reference data	1
5. Pinning information.....	2
6. Ordering information.....	2
7. Marking.....	2
8. Limiting values	3
9. Thermal characteristics	6
10. Characteristics.....	7
11. Application information	10
12. Package outline	15
13. Legal information	16
14. Contents.....	18

© WeEn Semiconductors Co., Ltd. 2018. All rights reserved

For more information, please visit: <http://www.ween-semi.com>

For sales office addresses, please send an email to: salesaddresses@ween-semi.com

Date of release: 22 August 2018
