

MAX9729

Stereo Headphone Amplifier with BassMax, Volume Control, and Input Mux

General Description

The MAX9729 stereo DirectDrive® headphone amplifier features bass boost, volume control, an input mux, and an I²C/SMBus-compatible serial interface. This makes the MAX9729 ideal for portable audio applications where space is at a premium and performance is essential. The MAX9729 operates from a single 1.8V to 3.6V, and uses Maxim's DirectDrive architecture, eliminating the need for large DC-blocking capacitors. The headphone amplifiers deliver 52mW into a 32Ω load, feature low 0.03% THD+N, and high 90dB PSRR. Maxim's industry-leading click-and-pop suppression circuitry reduces audible transients during power and shutdown cycles.

The BassMax feature boosts the bass response of the amplifier, improving audio reproduction for low-end headphones. The integrated volume control features 32 discrete volume levels along with a ramping function to ensure smooth transitions during shutdown cycles and input selection. The MAX9729's eight programmable maximum gain settings allow for a wide range of input signal levels. A 3:1 multiplexer/mixer allows the selection and summation of multiple stereo input signal sources. The MAX9729 also includes a dedicated BEEP input with independent attenuation control. BassMax, volume control, gain settings, and input selection are controlled using the I²C/SMBus-compatible serial interface. A lowpower, 5μA shutdown mode is controlled through an external logic input or the serial interface.

The MAX9729 consumes only 4.8mA of supply current, provides short-circuit and thermal-overload protection, and is specified over the -40°C to +85°C extended temperature range. The MAX9729 is available in a spacesaving 28-pin thin QFN package (5mm x 5mm x 0.8mm).

Pin Configuration appears at end of data sheet.

Simplified Block Diagram

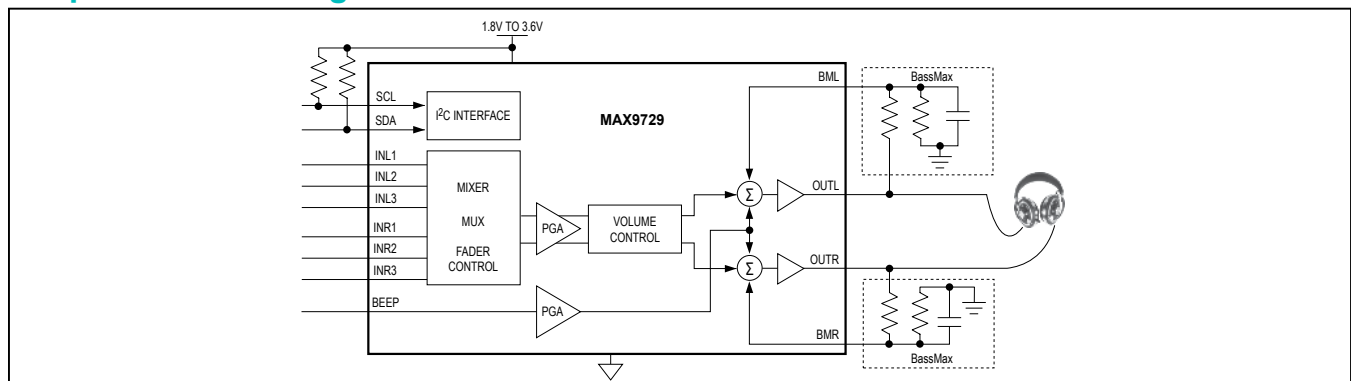

Features

- DirectDrive Headphone Amplifier Eliminates
- Bulky DC-Blocking Capacitors
- 3:1 Input Multiplexer with Digital-Fade Circuitry
- Software-Enabled Bass Boost
- 32-Step Integrated Volume Control
- Beep Input with Programmable Output Level
- Low Quiescent Current
- Industry-Leading Click-and-Pop Suppression
- I²C-Compatible 2-Wire Interface
- Short-Circuit Protection
- 1.8V to 3.6V Single-Supply Operation
- Available in Space-Saving, Thermally Efficient 28-Pin TQFN-EP (5mm x 5mm x 0.8mm)

Applications

- Portable CD/DVD/MD Players
- MP3/PMP Players
- Flat-Panel TVs
- Cell Phones

Ordering Information

PART	PIN-PACKAGE	SLAVE ADDRESS*
MAX9729ETI+	28 TQFN-EP**	101000_

Note: This device operates over the -40°C to +85°C operating temperature range.

+Denotes lead-free package.

*Last digit of slave address is pin programmable.

**EP = Exposed pad.

DirectDrive is a registered trademark of Maxim Integrated Products, Inc.

Absolute Maximum Ratings

V_{DD}, PV_{DD} to PGND or SGND.....-0.3V to +4V
 V_{DD} to PV_{DD}..... Internally Connected
 PV_{SS} to SV_{SS}.....±0.3V
 SGND to PGND.....±0.3V
 C1P to PGND.....-0.3V to (V_{DD} + 0.3V)
 C1N to PGND..... (PV_{SS} - 0.3V) to +0.3V
 PV_{SS}, SV_{SS} to PGND..... +0.3V to -4V
 INL_, INR_, BEEP to SGND.....(SV_{SS} - 0.3V) to (V_{DD} + 0.3V)
 SDA, SCL, BEEP_EN to PGND.....-0.3V to +4V
 SHDN to PGND.....-0.3V to (V_{DD} + 0.3V)
 OUT_ to PGND.....-3V to +3V
 BM_ to SGND.....-2V to +2V
 Duration of OUT_ Short Circuit to PGND..... Continuous

Continuous Current Into/Out of:
 V_{DD}, C1P, C1N, PGND, PV_{SS}, SV_{SS}, or OUT_±0.85A
 All other pins.....±20mA
 Continuous Power Dissipation (T_A = +70°C, multilayer board)
 28-Pin Thin QFN (derate 28.6mW/°C above +70°C) 0.2286mW
 Junction-to-Ambient Thermal Resistance (θ_{JA})
 28-Pin TQFN35°C/W
 Operating Temperature Range.....-40°C to +85°C
 Junction Temperature.....+150°C
 Storage Temperature Range.....-65°C to +150°C
 OUT_ ESD Protection (Human Body Model).....±8kV
 ESD Protection of All Other Pins.....±2kV
 Lead Temperature (soldering, 10s)+300°C

Stresses beyond those listed under "Absolute Maximum Ratings" may cause permanent damage to the device. These are stress ratings only, and functional operation of the device at these or any other conditions beyond those indicated in the operational sections of the specifications is not implied. Exposure to absolute maximum rating conditions for extended periods may affect device reliability.

Electrical Characteristics (3V Supply)

(V_{DD} = PV_{DD} = SHDN = 3V, PGND = SGND = 0V, C1 = C2 = C3 = 1µF, BM_ = 0V, maximum gain setting = 6dB, volume attenuation setting = -16dB (overall gain = -10dB), BassMax disabled. Load connected between OUT_ and PGND where specified. THD+N measurement BW = 22Hz to 22kHz. T_A = T_{MIN} to T_{MAX}, unless otherwise noted. Typical values are at T_A = +25°C.) (Note 1)

PARAMETER	SYMBOL	CONDITIONS	MIN	TYP	MAX	UNITS
GENERAL						
Supply Voltage Range	V _{DD}	(Note 2)	1.8		3.6	V
Charge-Pump and Logic Supply Voltage	PV _{DD}	(Note 2)	1.8		3.6	V
Quiescent Supply Current	I _{DD}	No load, BEEP_EN = V _{DD} (Note 3)		5.5	8	mA
Shutdown Supply Current	I _{DD_SHDN}	V _{SHDN} = 0V		5	10	µA
Turn-On Time	t _{ON}	From shutdown mode to full operation		200		µs
Beep Enable Time	t _{ON_BEEP}			12		µs
Thermal Shutdown Threshold	T _{THRES}			146		°C
Thermal Shutdown Hysteresis	T _{HYST}			13		°C
HEADPHONE AMPLIFIER						
Input Resistance	R _{IN}	Applicable to all maximum gain and volume settings	14	25	35	kΩ
Output Offset Voltage	V _{OSHP}	Measured between OUT_ and SGND, overall gain = -10dB (Note 3)		±0.7	±3.5	mV
BMR, BML Input Bias Current	I _{BIAS_BM}			±10	±100	nA

Electrical Characteristics (3V Supply) (continued)

($V_{DD} = PV_{DD} = \overline{SHDN} = 3V$, $PGND = SGND = 0V$, $C1 = C2 = C3 = 1\mu F$, $BM_ = 0V$, maximum gain setting = 6dB, volume attenuation setting = -16dB (overall gain = -10dB), BassMax disabled. Load connected between $OUT_$ and $PGND$ where specified. THD+N measurement BW = 22Hz to 22kHz. $T_A = T_{MIN}$ to T_{MAX} , unless otherwise noted. Typical values are at $T_A = +25^\circ C$.) (Note 1)

PARAMETER	SYMBOL	CONDITIONS		MIN	TYP	MAX	UNITS
Power-Supply Rejection Ratio	PSRR	(Note 3)	$V_{DD} = 1.8V$ to $3.6V$, overall gain = 6dB	72	95		dB
			$f = 217Hz$, $100mV_{P-P}$ ripple, overall gain = 26dB		90		
			$f = 1kHz$, $100mV_{P-P}$ ripple, overall gain = 26dB		82		
			$f = 20kHz$, $100mV_{P-P}$ ripple, overall gain = 26dB		58		
Output Power	P_{OUT}	THD+N = 1%, $f_{IN} = 1kHz$, overall gain = 1.8dB, $T_A = +25^\circ C$ (Note 4)	$R_L = 16\Omega$	12	49		mW
			$R_L = 32\Omega$	21	52		
Total Harmonic Distortion Plus Noise	THD+N	$f_{IN} = 1kHz$, overall gain = 3.5dB (Note 4)	$R_L = 16\Omega$, $P_{OUT} = 42mW$		0.04		%
			$R_L = 32\Omega$, $P_{OUT} = 40mW$		0.04		
Maximum Gain	A_{VMAX}	Register 0x01, B[2:0] = 000			3.5		dB
		Register 0x01, B[2:0] = 001			6		
		Register 0x01, B[2:0] = 010			8		
		Register 0x01, B[2:0] = 011			10		
		Register 0x01, B[2:0] = 100			19.5		
		Register 0x01, B[2:0] = 101			22		
		Register 0x01, B[2:0] = 110			24		
		Register 0x01, B[2:0] = 111			26		
Beep Input Attenuation	A_{V_BEEP}	Register 0x01, B[7:5] = 000			10		dB
		Register 0x01, B[7:5] = 001			20		
		Register 0x01, B[7:5] = 010			30		
		Register 0x01, B[7:5] = 011			40		
		Register 0x01, B[7:5] = 100			50		
		Register 0x01, B[7:5] = 101			52		
		Register 0x01, B[7:5] = 110			54		
		Register 0x01, B[7:5] = 111			56		
Signal-to-Noise Ratio	SNR	$R_L = 32\Omega$, $V_{OUT} = 1V_{RMS}$	BW = 22Hz to 22kHz		99		dB
			BW = 22Hz to 22kHz and A-weighted		101		
Slew Rate	SR				0.5		V/ μs
Capacitive Drive		No sustained oscillations			200		pF
Output Resistance in Shutdown	R_{OUT_SHDN}	$V_{\overline{SHDN}} = 0V$, measured from $OUT_ $ to $SGND$			20		k Ω

Electrical Characteristics (3V Supply) (continued)

($V_{DD} = PV_{DD} = \overline{SHDN} = 3V$, $PGND = SGND = 0V$, $C1 = C2 = C3 = 1\mu F$, $BM_+ = 0V$, maximum gain setting = 6dB, volume attenuation setting = -16dB (overall gain = -10dB), BassMax disabled. Load connected between OUT_+ and $PGND$ where specified. THD+N measurement BW = 22Hz to 22kHz. $T_A = T_{MIN}$ to T_{MAX} , unless otherwise noted. Typical values are at $T_A = +25^\circ C$.) (Note 1)

PARAMETER	SYMBOL	CONDITIONS	MIN	TYP	MAX	UNITS
Click-and-Pop Level	K_{CP}	Peak voltage, A-weighted, 32 samples per second (Notes 3 and 5)	Into shutdown		81	dBV
			Out of shutdown		80	
Charge-Pump Switching Frequency	f_{CP}		505	600	730	kHz
Crosstalk		L to R, or R to L, $f = 10kHz$, $V_{OUT} = 1V_{RMS}$, $R_L = 32\Omega$, both channels loaded		78		dB
DIGITAL INPUTS (SHDN, SDA, SCL, BEEP_EN)						
Input High Voltage	V_{IH}		1.4			V
Input Low Voltage	V_{IL}				0.4	V
Input Leakage Current			-1		+1	μA
DIGITAL OUTPUTS (SDA)						
Output Low Voltage	V_{OL}	$I_{OL} = 3mA$			0.4	V
Output High Current	I_{OH}	$V_{SDA} = V_{DD}$			1	μA

Electrical Characteristics (2.4V Supply)

($V_{DD} = PV_{DD} = \overline{SHDN} = 2.4V$, $PGND = SGND = 0V$, $C1 = C2 = C3 = 1\mu F$, $BM_+ = 0V$, maximum gain setting = 6dB, volume attenuation setting = -16dB (overall gain = -10dB), BassMax disabled. Load connected between OUT_+ and $PGND$ where specified. THD+N measurement BW = 22Hz to 22kHz. $T_A = T_{MIN}$ to T_{MAX} , unless otherwise noted. Typical values are at $T_A = +25^\circ C$.) (Note 1)

PARAMETER	SYMBOL	CONDITIONS	MIN	TYP	MAX	UNITS
Quiescent Current	I_{DD}	No load (Note 3)		4.5		mA
Shutdown Current	I_{SHDN}	$V_{\overline{SHDN}} = 0V$		4		μA
Output Power	P_{OUT}	THD+N = 1%, $f_{IN} = 1kHz$, overall gain = 3.5dB, $T_A = +25^\circ C$ (Note 4)	$R_L = 16\Omega$		32	mW
			$R_L = 32\Omega$		32	
Total Harmonic Distortion Plus Noise	THD+N	$f_{IN} = 1kHz$, overall gain = 3.5dB (Note 4)	$R_L = 16\Omega$, $P_{OUT} = 23mW$		0.03	%
			$R_L = 32\Omega$, $P_{OUT} = 23mW$		0.03	
Power-Supply Rejection Ratio	PSRR	100mV _{p-p} ripple (Note 3)	$f = 217Hz$		90	dB
			$f = 1kHz$		85	
			$f = 10kHz$		61	

Electrical Characteristics (2.4V Supply) (continued)

($V_{DD} = PV_{DD} = \overline{SHDN} = 2.4V$, $PGND = SGND = 0V$, $C1 = C2 = C3 = 1\mu F$, $BM_ = 0V$, maximum gain setting = 6dB, volume attenuation setting = -16dB (overall gain = -10dB), BassMax disabled. Load connected between $OUT_$ and $PGND$ where specified. THD+N measurement BW = 22Hz to 22kHz. $T_A = T_{MIN}$ to T_{MAX} , unless otherwise noted. Typical values are at $T_A = +25^\circ C$.) (Note 1)

PARAMETER	SYMBOL	CONDITIONS		MIN	TYP	MAX	UNITS
Signal-to-Noise Ratio	SNR	$R_L = 32\Omega$, $V_{OUT} = 1V_{RMS}$, overall gain = 3.5dB	BW = 22Hz to 22kHz		98		dB
			BW = 22Hz to 22kHz and A-weighted		101		
Click-and-Pop Level	K_{CP}	Peak voltage, A-weighted, 32 samples per second (Notes 3 and 5)	Into shutdown		79		dBV
			Out of shutdown		79		

Timing Characteristics

($V_{DD} = PV_{DD} = \overline{SHDN} = 3V$, $PGND = SGND = 0V$, $C1 = C2 = C3 = 1\mu F$, $BM_ = 0V$, maximum gain setting = 6dB, volume setting = -16dB (overall gain = -10dB), BassMax disabled. Load connected between $OUT_$ and $PGND$ where specified. $T_A = T_{MIN}$ to T_{MAX} , unless otherwise noted. Typical values are at $T_A = +25^\circ C$.) (Notes 1 and 6)

PARAMETER	SYMBOL	CONDITIONS	MIN	TYP	MAX	UNITS
Serial Clock Frequency	f_{SCL}		0		400	kHz
Bus Free Time Between a STOP and a START Condition	t_{BUF}		1.3			μs
Hold Time Repeated for a START Condition	$t_{HD:STA}$		0.6			μs
Low Period of the SCL Clock	t_{LOW}		1.3			μs
High Period of the SCL Clock	t_{HIGH}		0.6			μs
Setup Time for a Repeated START Condition	$t_{SU:STA}$		0.6			μs
Data Hold Time	$t_{HD:DAT}$		0		0.9	μs
Data Setup Time	$t_{SU:DAT}$		100			ns
Rise Time of Both SDA and SCL Signals	t_r				300	ns
Fall Time of Both SDA and SCL Signals	t_f				300	ns
Setup Time for STOP Condition	$t_{SU:STO}$		0.6			μs
Pulse Width of Suppressed Spike	t_{SP}			50		ns
Capacitive Load for Each Bus Line	C_{L_BUS}				400	pF

Note 1: All specifications are 100% tested at $T_A = +25^\circ C$. Temperature limits are guaranteed by design.

Note 2: V_{DD} and PV_{DD} must be connected together.

Note 3: Inputs AC-coupled to $SGND$.

Note 4: Both channels loaded and driven in phase.

Note 5: Headphone testing performed with a 32Ω resistive load connected to $PGND$. Mode transitions are controlled by \overline{SHDN} . KCP level is calculated as $20\log[(\text{peak voltage during mode transition, no input signal})/1V_{RMS}]$. Units are expressed in dBV.

Note 6: Guaranteed by design.

Typical Operating Characteristics

($V_{DD} = PV_{DD} = \overline{SHDN} = 3V$, $PGND = SGND = 0V$, $C1 = C2 = C3 = 1\mu F$, $C_{IN} = 1\mu F$ (1206 case size, X7R dielectric ceramic capacitor), $BM_{-} = 0V$, maximum gain setting = 3.5dB, volume attenuation setting = 0dB (total voltage gain = 3.5dB), BassMax disabled. Load connected between OUT_{-} and $PGND$ where specified. THD+N measurement BW = 22Hz to 22kHz. Both channels loaded and driven in phase. $T_A = +25^{\circ}C$, unless otherwise noted.)

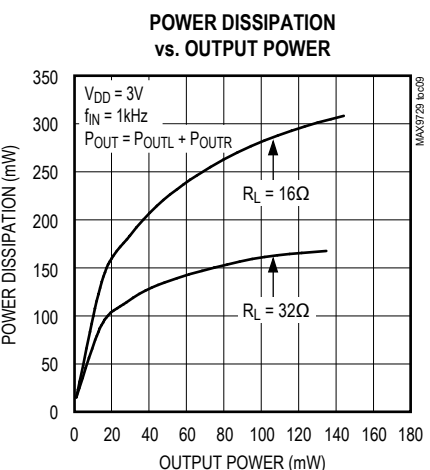
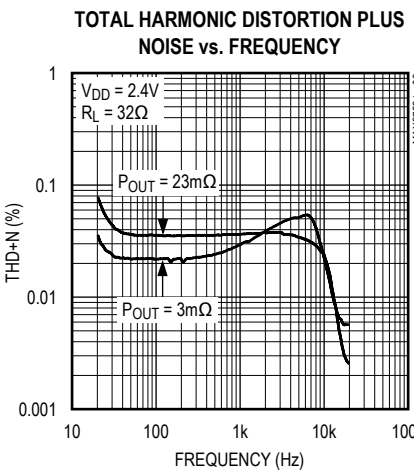
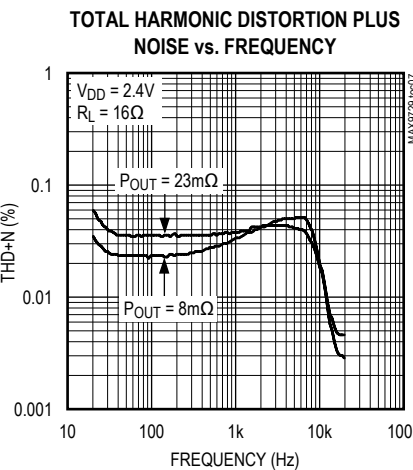
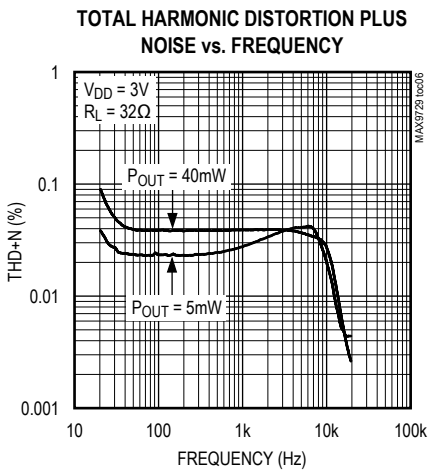
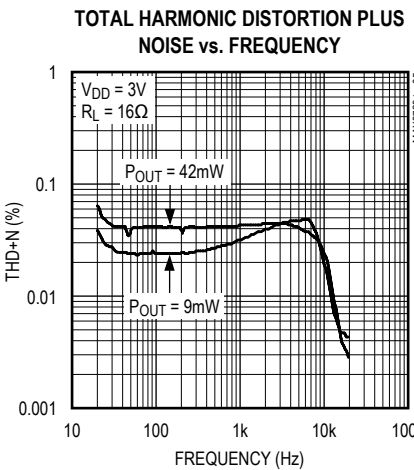
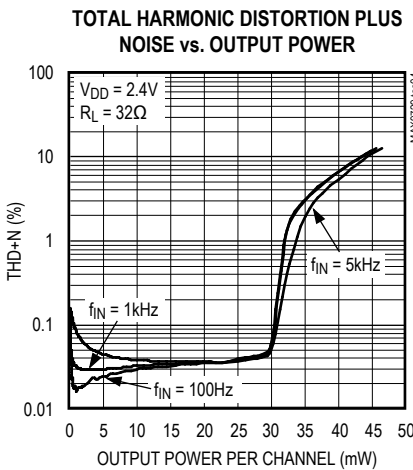
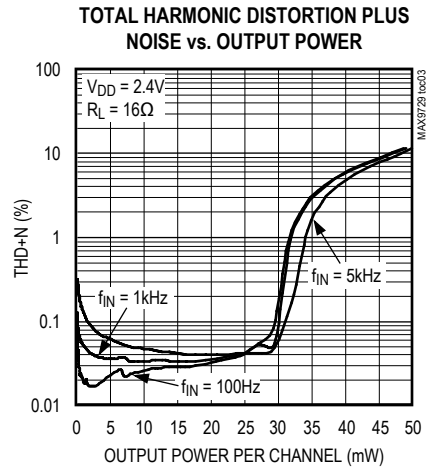
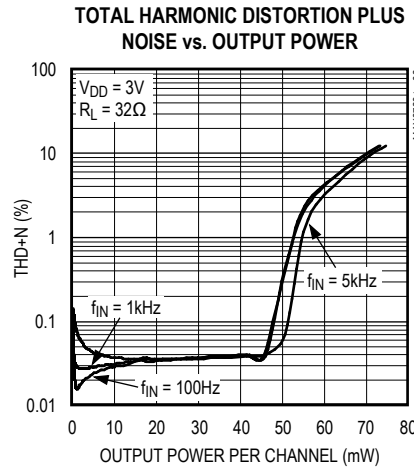
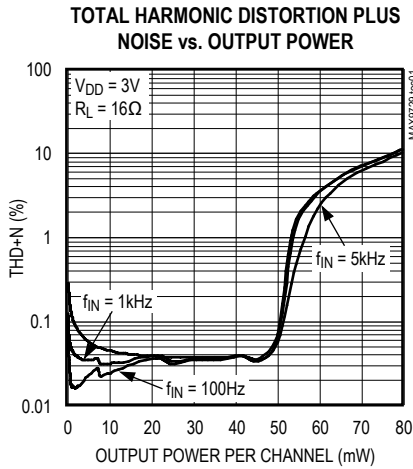

Typical Operating Characteristics (continued)

($V_{DD} = PV_{DD} = \overline{SHDN} = 3V$, $PGND = SGND = 0V$, $C1 = C2 = C3 = 1\mu F$, $C_{IN} = 1\mu F$ (1206 case size, X7R dielectric ceramic capacitor), $BM_{-} = 0V$, maximum gain setting = 3.5dB, volume attenuation setting = 0dB (total voltage gain = 3.5dB), BassMax disabled. Load connected between OUT_{-} and $PGND$ where specified. THD+N measurement BW = 22Hz to 22kHz. Both channels loaded and driven in phase. $T_A = +25^{\circ}C$, unless otherwise noted.)

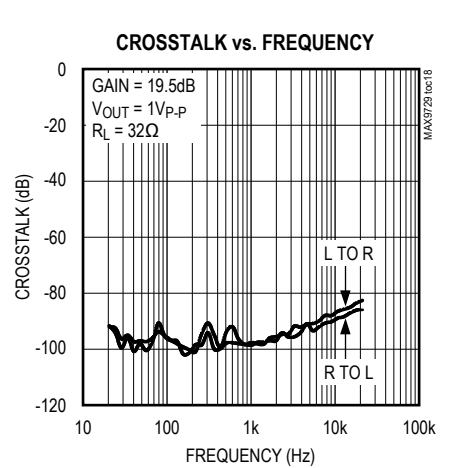
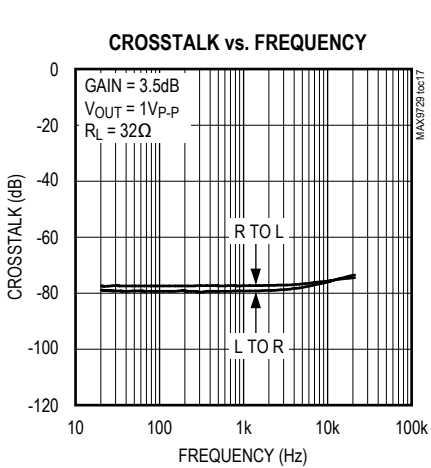
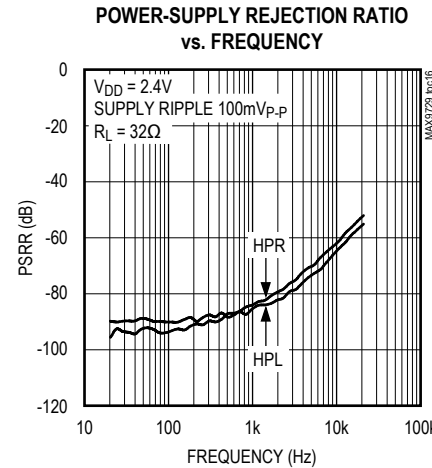
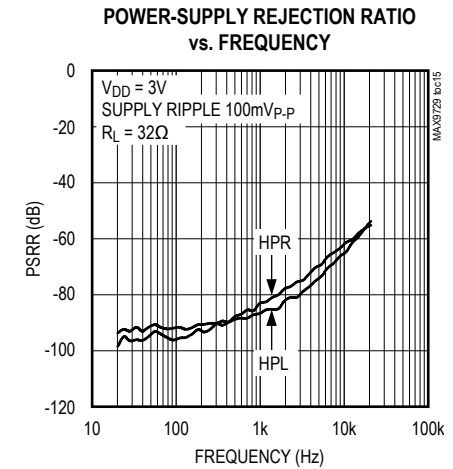
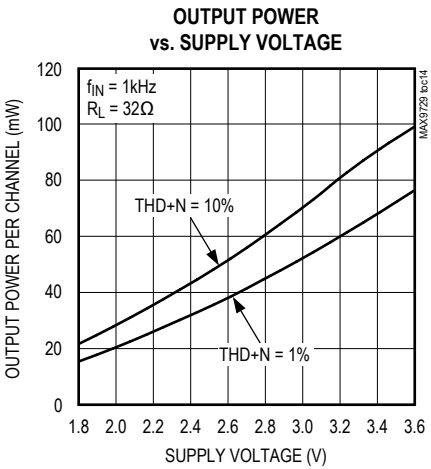
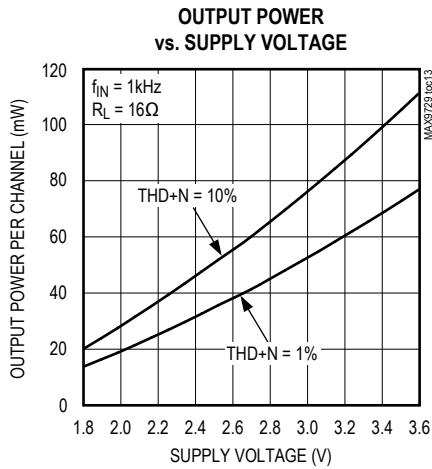
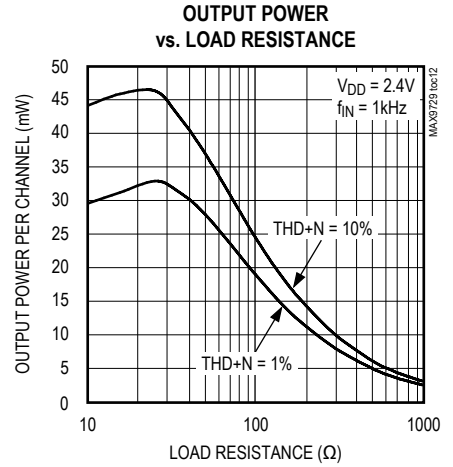
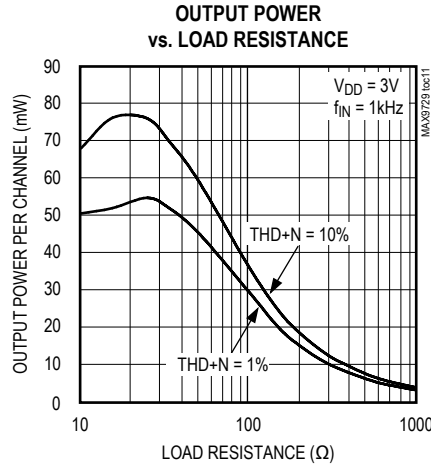
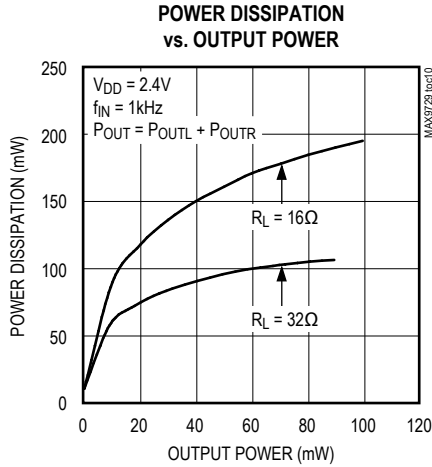

Typical Operating Characteristics (continued)

($V_{DD} = PV_{DD} = \overline{SHDN} = 3V$, $PGND = SGND = 0V$, $C1 = C2 = C3 = 1\mu F$, $C_{IN} = 1\mu F$ (1206 case size, X7R dielectric ceramic capacitor), $BM_{-} = 0V$, maximum gain setting = 3.5dB, volume attenuation setting = 0dB (total voltage gain = 3.5dB), BassMax disabled. Load connected between OUT_{-} and $PGND$ where specified. THD+N measurement BW = 22Hz to 22kHz. Both channels loaded and driven in phase. $T_A = +25^{\circ}C$, unless otherwise noted.)

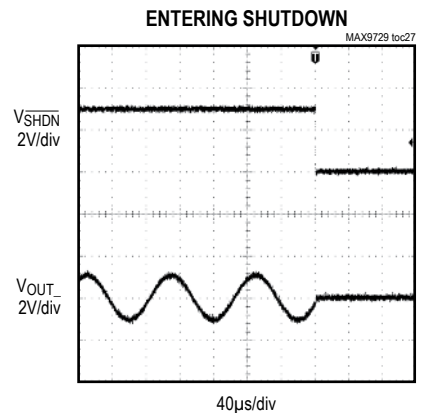
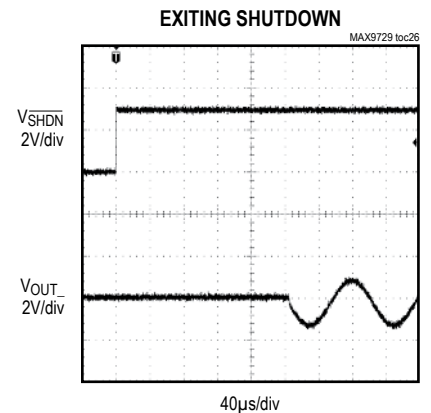
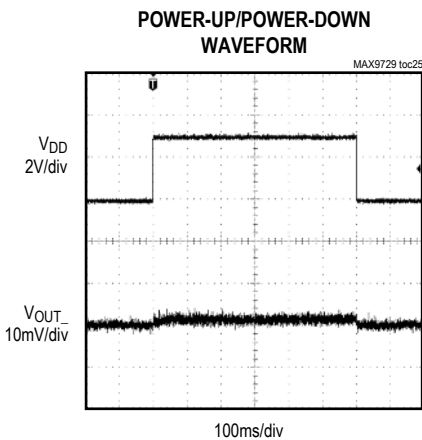
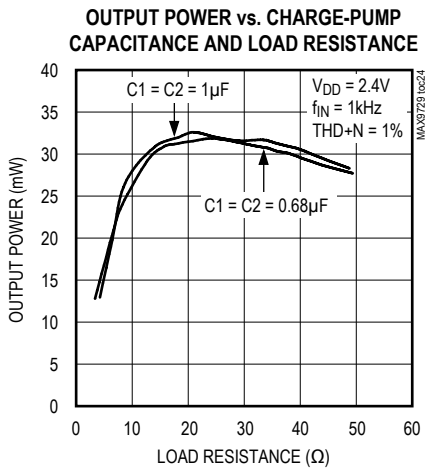
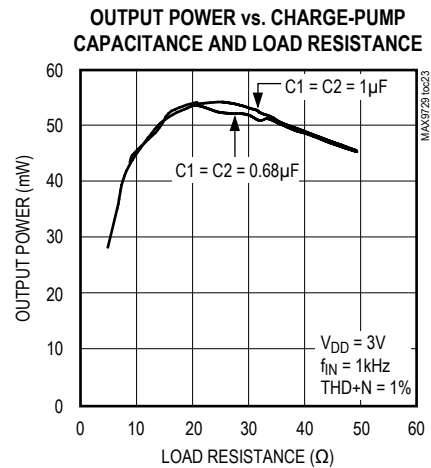
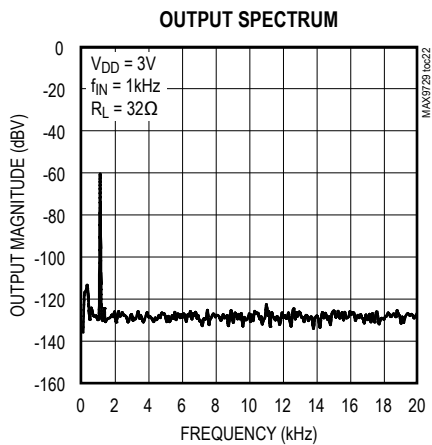
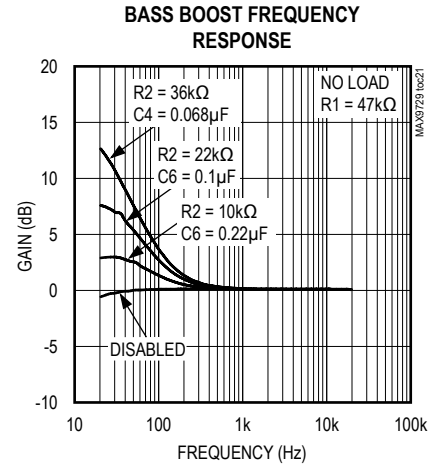
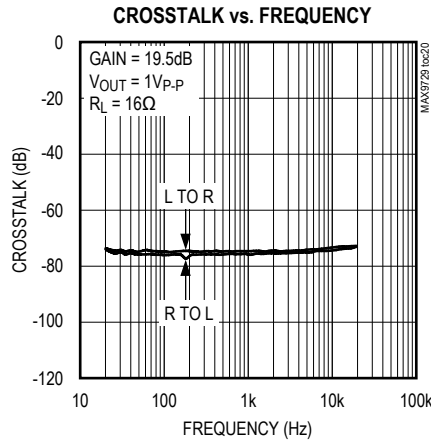
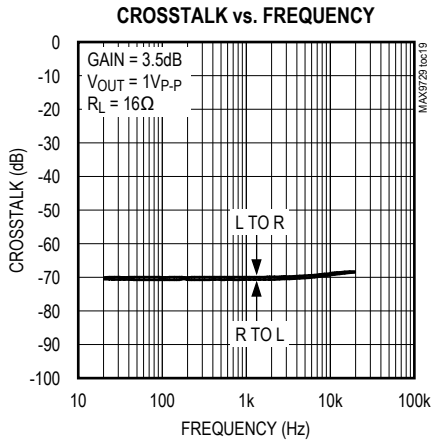

Typical Operating Characteristics (continued)

($V_{DD} = PV_{DD} = \overline{SHDN} = 3V$, $PGND = SGND = 0V$, $C1 = C2 = C3 = 1\mu F$, $C_{IN} = 1\mu F$ (1206 case size, X7R dielectric ceramic capacitor), $BM_{-} = 0V$, maximum gain setting = 3.5dB, volume attenuation setting = 0dB (total voltage gain = 3.5dB), BassMax disabled. Load connected between OUT_{-} and $PGND$ where specified. THD+N measurement BW = 22Hz to 22kHz. Both channels loaded and driven in phase. $T_A = +25^{\circ}C$, unless otherwise noted.)

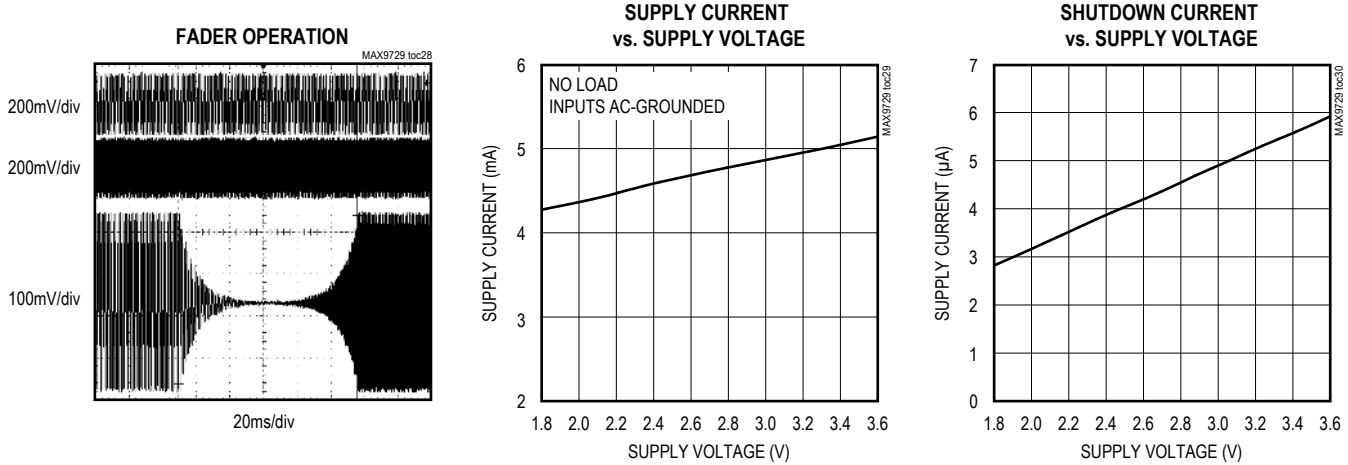

Pin Description

PIN	NAME	FUNCTION
1	INR2	Right-Channel Input 2
2	INR3	Right-Channel Input 3
3	SGND	Signal Ground. Connect SGND to PGND at a single point on the PCB near the device.
4, 8, 15, 22	N.C.	No Connection. Not internally connected.
5	ADD	Slave Address Selection Input. Connect ADD to V_{DD} to set the device slave address to 1010001 or to PGND to set the device slave address to 1010000.
6	PV _{SS}	Charge-Pump Output. Connect to SV _{SS} .
7	SDA	Serial Data Input. Connect a pullup resistor greater than 500 Ω from SDA to PV _{DD} .
9	C1N	Charge-Pump Flying Capacitor Negative Terminal. Connect a 1 μF capacitor between C1P and C1N.
10	PGND	Power Ground. Connect PGND to SGND at a single point on the PCB near the device.
11	C1P	Charge-Pump Flying Capacitor Positive Terminal. Connect a 1 μF capacitor between C1P and C1N.
12	SCL	Serial Clock Input. Connect a pullup resistor greater than 500 Ω from SCL to PV _{DD} .
13	PV _{DD}	Charge-Pump and Logic Power-Supply Input. Bypass PV _{DD} to PGND with a 1 μF capacitor and connect to V_{DD} . PV _{DD} and V_{DD} are internally connected and should each have a 1 μF bypass capacitor located as close to the device as possible.
14	SV _{SS}	Headphone Amplifier Negative Power-Supply Input. Connect to PV _{SS} and bypass with a 1 μF capacitor to PGND.

Pin Description (continued)

PIN	NAME	FUNCTION
16	BMR	Right BassMax Input. Connect an external passive network between OUTR and BMR to apply bass boost to the right-channel output. See the <i>BassMax Gain-Setting Components</i> section. Connect BMR to SGND if BassMax is not used.
17	OUTR	Right Headphone Output
18	OUTL	Left Headphone Output
19	BML	Left BassMax Input. Connect an external passive network between OUTL and BML to apply bass boost to the left-channel output. See the <i>BassMax Gain-Setting Components</i> section. Connect BML to SGND, if BassMax is not used.
20	BEEP_EN	Beep Enable Input. Connect BEEP_EN to PV _{DD} to enable the beep amplifier or to PGND to disable the beep amplifier.
21	$\overline{\text{SHDN}}$	Active-Low Shutdown Input. Drive SHDN low to disable the MAX9729. Connect $\overline{\text{SHDN}}$ to V _{DD} while B7 in command register 0x00 is equal to 1 for normal operation (see <i>Command Registers</i> section).
23	V _{DD}	Power-Supply Input. Bypass V _{DD} to PGND with a 1 μ F capacitor and connect to PV _{DD} . V _{DD} and PV _{DD} are internally connected and should each have a 1 μ F bypass capacitor located as close to the device as possible.
24	BEEP	Beep Input
25	INL1	Left-Channel Input 1
26	INL2	Left-Channel Input 2
27	INL3	Left-Channel Input 3
28	INR1	Right-Channel Input 1
EP	EP	Exposed Paddle. Connect EP to SV _{SS} or leave unconnected.

Detailed Description

The MAX9729 stereo headphone amplifier features Maxim's DirectDrive architecture, eliminating the large output-coupling capacitors required by conventional single-supply headphone amplifiers. The MAX9729 consists of two 52mW Class AB headphone amplifiers, 3:1 stereo input multiplexer/mixer, two adjustable gain preamplifiers, a dedicated beep amplifier with independent gain control, hardware/software shutdown control, inverting charge pump, integrated 32-level volume control, BassMax circuitry, comprehensive click-and-pop suppression circuitry, and an I²C/SMBus-compatible interface (see the *Functional Diagram/Typical Operating Circuit*). A negative power supply (PV_{SS}) is created internally by inverting the positive supply (PV_{DD}). Powering the amplifiers from V_{DD} and PV_{SS} increases the dynamic range of the amplifiers to almost twice that of other single-supply amplifiers, increasing the total available output power.

An I²C/SMBus-compatible interface allows serial communication between the MAX9729 and a microcontroller. The MAX9729's slave address is programmed to one of

two different values using the ADD input allowing two MAX9729 ICs to share the same bus (see Table 1). The internal command registers control the shutdown mode of the MAX9729, select/mix input signal sources, enable the BassMax circuitry, headphone and beep amplifier gains, and set the volume level (see Table 2). The MAX9729's BassMax circuitry improves audio reproduction by boosting the bass response of the amplifier, compensating for any low-frequency attenuation introduced by the headphone. External components set the MAX9729's overall gain allowing for custom gain settings (see the *BassMax Gain-Setting Components* section).

DirectDrive

Traditional single-supply headphone amplifiers have their outputs biased about a nominal DC voltage, typically half the supply, for maximum dynamic range. Large coupling capacitors are needed to block this DC bias from the headphone. Without these capacitors, a significant amount of DC current flows to the headphone, resulting in unnecessary power dissipation and

possible damage to both headphone and headphone amplifier. In addition to the cost and size disadvantages, the DC-blocking capacitors required by conventional headphone amplifiers limit low-frequency response and can distort the audio signal.

Maxim's DirectDrive architecture uses a charge pump to create an internal negative supply voltage. This allows the MAX9729 headphone amplifier outputs to be biased about ground, almost doubling the dynamic range while operating from a single supply (see Figure 1). With no DC component, there is no need for the large DC-blocking capacitors. Instead of two large (up to 220 μ F) tantalum capacitors, the MAX9729 charge pump requires only two small 1 μ F ceramic capacitors, conserving board space, reducing cost, and improving the frequency response of the headphone amplifier. See the Output Power vs. Charge-Pump Capacitance and Load Resistance graph in the *Typical Operating Characteristics* for details of the possible capacitor sizes.

Charge Pump

The MAX9729 features a low-noise charge pump. The 610kHz switching frequency is well beyond the audio range, and does not interfere with the audio signals. This enables the MAX9729 to achieve an SNR of 99dB. The switch drivers feature a controlled switching speed that minimizes noise generated by turn-on and turn-off transients. Limiting the switching speed of the charge pump also minimizes di/dt noise caused by the parasitic bond wire and trace inductances.

Click-and-Pop Suppression

In conventional single-supply headphone amplifiers, the output-coupling capacitor is a major contributor of audible clicks and pops. The amplifier charges the coupling capacitor to its output bias voltage at startup. During shutdown, the capacitor is discharged. The charging and discharging results in a DC shift across the capacitor, which appears as an audible transient at the headphone speaker. Since the MAX9729 headphone amplifier does not require output-coupling capacitors, no audible transients occur.

Additionally, the MAX9729 features extensive click-and-pop suppression that eliminates any audible transient sources internal to the device. The Power-Up/Power-Down Waveform in the *Typical Operating Characteristics* shows that there are minimal transients at the output upon startup or shutdown.

In most applications, the preamplifier driving the MAX9729 has a DC bias of typically half the supply. The input-

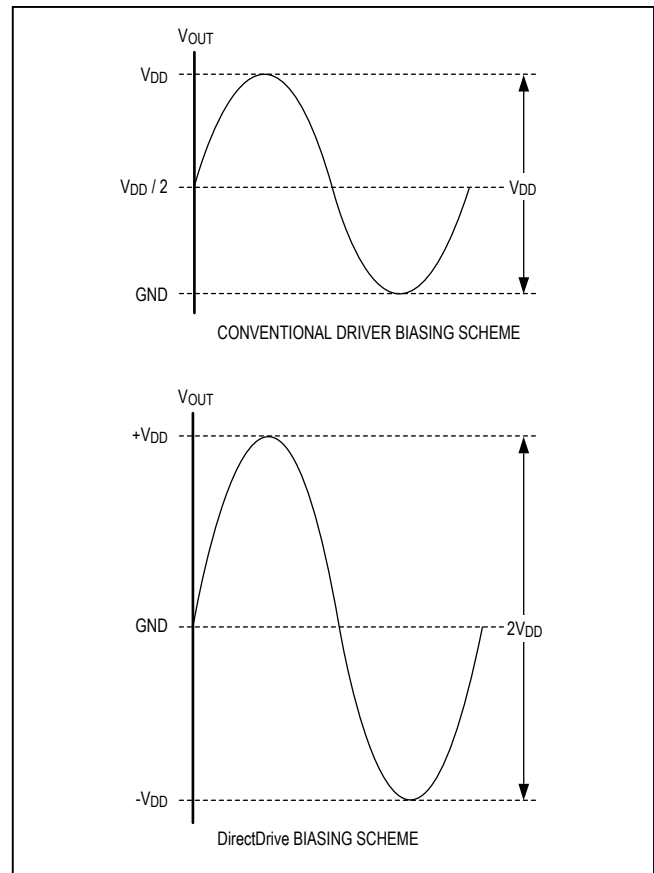

Figure 1. Traditional Amplifier Output vs. MAX9729 DirectDrive Output

coupling capacitor is charged to the preamplifier's bias voltage through the MAX9729's input resistor (R_{IN}) during startup. The resulting shift across the capacitor creates a voltage transient that must settle before the 50ms turn-on time has elapsed. Delay the rise of \overline{SHDN} by at least 4 time constants ($4 \times R_{IN} \times C_{IN}$) relative to the start of the preamplifier to avoid clicks/pops caused by the input filter.

Shutdown

The MAX9729 features a 5 μ A, low-power shutdown mode that reduces quiescent current consumption and extends battery life. Shutdown is controlled by the \overline{SHDN} logic input or software interface. Driving the \overline{SHDN} input low disables the drive amplifiers, bias circuitry, charge pump, and sets the headphone amplifier output resistance to 20k Ω . Similarly, the MAX9729 enters shutdown when bit seven (B7) in the command register, 0x00, is set to 0 (see the *Command Registers* section). \overline{SHDN} and B7 must be high to enable the MAX9729. The I²C/SMBus interface is active and the contents of the command register are not

affected when in shutdown. This allows the master device to write to the MAX9729 while in shutdown.

When a shutdown is activated, either hardware ($\overline{\text{SHDN}}$ pin) or software (I²C register), the volume is smoothly reduced, according to a constant slope ramp. Similarly, when a shutdown is deactivated, either hardware or software, the volume is smoothly increased, according to a constant slope ramp, until the volume programmed in the register file is reached.

BassMax (Bass Boost)

Typical headphones do not have a flat-frequency response. The small physical size of the diaphragm does not allow the headphone speaker to efficiently reproduce low frequencies. This physical limitation results in attenuated bass response. The MAX9729 includes a bass boost feature that compensates for the headphone's poor bass response by increasing the amplifier gain at low frequencies.

The DirectDrive output of the MAX9729 has more headroom than typical single-supply headphone amplifiers. This additional headroom allows boosting the bass frequencies without the output signal clipping.

Program the BassMax gain and cutoff frequency with external components connected between OUT₋ and BM₋ (see the *BassMax Gain-Setting Components* section and the *Functional Diagram/Typical Operating Circuit*). Use the I²C-compatible interface to program the command register to enable/disable the BassMax circuit.

BM₋ is connected to the noninverting input of the output amplifier when BassMax is enabled. BM₋ is pulled to SGND when BassMax is disabled. The typical application of the BassMax circuit involves feeding a lowpass-filtered version of the output signal back to the amplifier. This is

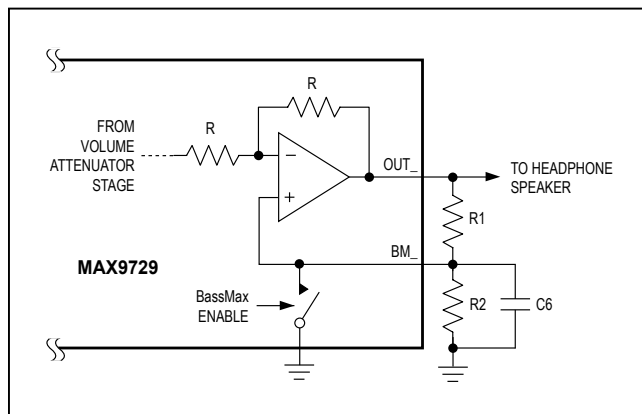

Figure 2. BassMax External Connections

realized using positive feedback from OUT₋ to BM₋. Figure 2 shows the connections needed to implement BassMax.

Maximum Gain Control

The MAX9729 features eight different programmable maximum gain settings ranging from +3.5dB to +26dB (see Table 8). Bits [2:0] in command register 0x01 control the maximum gain setting (AV₋MAX).

Volume Control

The MAX9729 includes a 32-level volume control that adjusts the total voltage gain of the headphone amplifier according to the values of bits [4:0] in the 0x00 command register. With BassMax disabled, the total voltage gain of the MAX9729 is equal to:

$$AV_{\text{TOTAL}} = AV_{\text{MAX}} - \text{ATTEN}(\text{dB})$$

where AV₋TOTAL is the total voltage gain in dB, AV₋MAX is the maximum gain setting in dB, and ATTEN is the volume attenuation in dB.

Tables 5a, 5b, 5c show all the possible volume attenuation settings and the resulting AV₋TOTAL with BassMax disabled. Figure 8 shows the volume control transfer function. Mute attenuation is typically better than 100dB when driving a 32Ω load. To perform smooth-sounding volume changes, step through all intermediate volume settings at a rate of approximately 2ms per step when a volume change occurs.

Automatic Volume Ramping During Mode Transitions and Input Source Selection

The MAX9729 implements an automatic volume rampup/ramp-down function when exiting/entering shutdown and when selecting different input signal paths with the internal 3:1 multiplexer. The automatic volume rampup/ramp-down function steps through each intermediate volume setting at a rate of 1.5ms per step allowing for smooth sounding volume transitions. When exiting/entering shutdown, the volume ramp-up/rampdown function is implemented regardless of whether the shutdown command is initiated by an I²C command or the $\overline{\text{SHDN}}$ input. When exiting shutdown, the volume is ramped up to the value stored in register 0x00 (see Table 2). When selecting a new input signal path with the multiplexer, the MAX9729 first ramps down the volume, selects the new input source, and then ramps the volume back up to the value stored in register 0x00. This prevents any audible clicks and pops due to abrupt changes in signal amplitude when selecting a different input signal source.

BEEP Input

The MAX9729 features a BEEP input with eight different attenuation settings (see Table 6). The BEEP input is useful for applications requiring the routing of a system alert signal to the stereo audio path. The attenuation value of the BEEP input is set by bits [7:5] in the 0x01 command register (see Tables 2 and 6). The attenuation settings of the BEEP input are independent of the volume settings stored in register 0x00 (see Table 2). The BEEP input is enabled when BEEP_EN is connected to V_{DD} and disabled when driven low. When BEEP_EN is high, the selected INL_ and INR_ inputs are disconnected from the signal path and the BEEP input signal is routed to both headphone outputs after being attenuated by the value set by bits [7:5] in register 0x01. When BEEP_EN is low, the BEEP input is disconnected from the signal path and the selected INL_ and INR_ inputs are reconnected.

Input Multiplexer/Mixer

The MAX9729 includes a stereo 3:1 multiplexer/mixer, allowing selection and mixing of three different stereo input sources. Bits [6:5] in register 0x00 control the selection/mixing of the input signal sources (see Tables 2 and 4). When all three stereo inputs are selected (Bits [6:5] = 11), the stereo signals are summed (mixed) together and connected to the signal path. The MAX9729 implements the automatic volume ramping function when an input source change occurs to ensure smooth sounding transitions. Clipping may occur if three high level signals are summed. Reprogram the preamplifier maximum gain setting to compensate.

Serial Interface

The MAX9729 features an I²C/SMBus-compatible 2-wire serial interface consisting of a serial data line (SDA) and a serial clock line (SCL). SDA and SCL facilitate bidirection-

al communication between the MAX9729 and the master at clock rates up to 400kHz. Figure 3 shows the 2-wire interface timing diagram. The MAX9729 is a transmit/receive slave-only device, relying upon a master device to generate the clock signal. The master device, typically a microcontroller, initiates data transfer on the bus and generates SCL to permit that transfer.

A master device communicates to the MAX9729 by transmitting the slave address with the Read/Write (R/W) bit followed by the data word. Each transmit sequence is framed by a START (S) or REPEATED START (Sr) condition and a STOP (P) condition. Each word transmitted over the bus is 8 bits long and is always followed by an acknowledge or not acknowledge clock pulse.

The MAX9729 SDA line operates as both an input and an open-drain output. A pullup resistor, greater than 500Ω, is required on the SDA bus. The MAX9729 SCL line operates as an input only. A pullup resistor, greater than 500Ω, is required on SCL unless the MAX9729 is operating in a single-master system where the master device has a push-pull SCL output. Series resistors in line with SDA and SCL are optional. Series resistors protect the digital inputs of the MAX9729 from highvoltage spikes on the bus lines, and minimize crosstalk and undershoot of the bus signals.

Bit Transfer

One data bit is transferred during each SCL cycle. The data on SDA must remain stable during the high period of the SCL pulse since changes in SDA while SCL is high are control signals (see the *START and STOP Conditions* section). SDA and SCL idle high when the I²C bus is not busy.

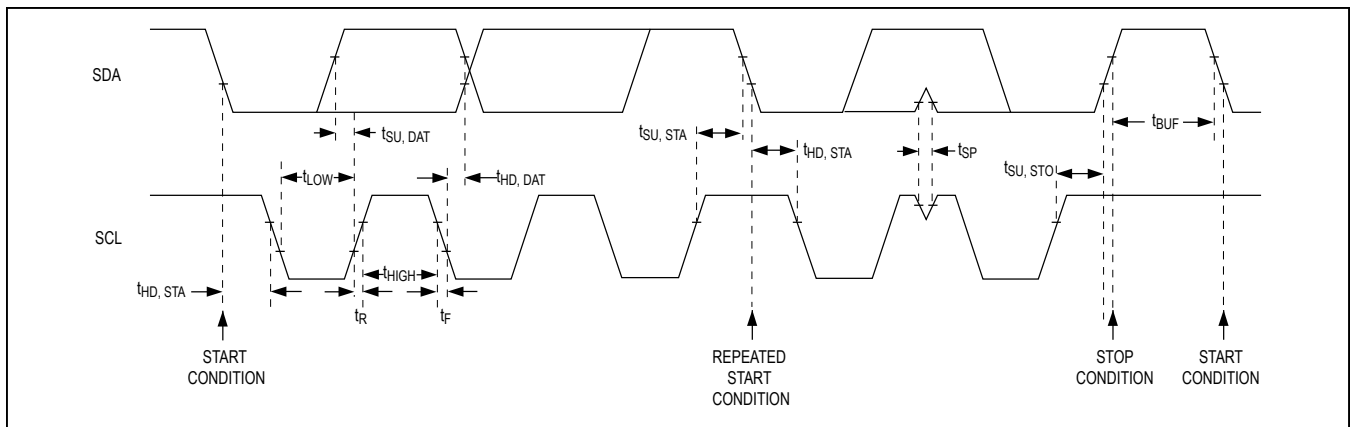

Figure 3. 2-Wire Serial-Interface Timing Diagram

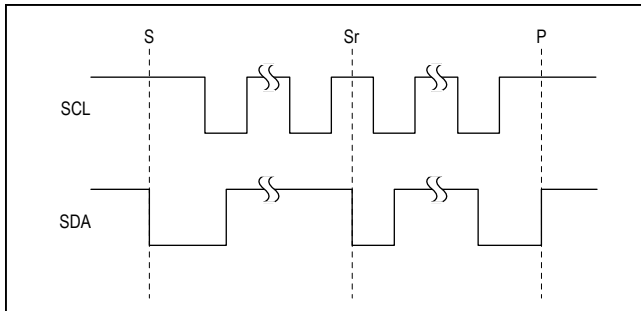

Figure 4. START, STOP, and REPEATED START Conditions

START and STOP Conditions

SDA and SCL idle high when the bus is not in use. A master device initiates communication by issuing a START condition. A START condition is a high-to-low transition on SDA with SCL high. A STOP condition is a low-to-high transition on SDA while SCL is high (see Figure 4). A START condition from the master signals the beginning of a transmission to the MAX9729. The master terminates transmission, and frees the bus, by issuing a STOP condition. The bus remains active if a REPEATED START condition is generated instead of a STOP condition.

Early STOP Conditions

The MAX9729 recognizes a STOP condition at any point during data transmission except if the STOP condition occurs in the same high clock pulse as a START condition. At least one clock pulse must separate any START and STOP conditions.

Slave Address

The slave address of the MAX9729 is pin programmable using the ADD input to one of two different values (see Table 1). The slave address is defined as the 7 most significant bits (MSBs) of the serial data transmission. The first byte of information sent to the MAX9729 after the START condition must contain the slave address and R/W bit. R/W bit indicates whether the master is writing to or reading from the MAX9729 (R/W = 0 selects the write condition, R/W = 1 selects the read condition). After

Table 1. MAX9729 Slave Address with R/W Bit

ADD	MAX9729 SLAVE ADDRESS							R/W
	A6 (MSB)	A5	A4	A3	A2	A1	A0	
GND	1	0	1	0	0	0	0	0
V _{DD}	1	0	1	0	0	0	1	0

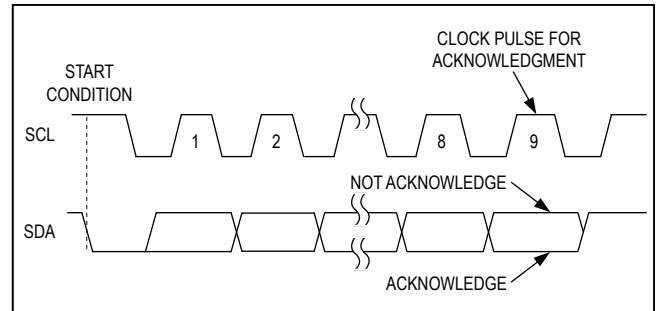

Figure 5. Acknowledge

receiving the proper address, the MAX9729 issues an ACK by pulling SDA low for one clock cycle.

Acknowledge

The acknowledge bit (ACK) is the ninth bit attached to any byte transmitted over the serial interface (see Figure 5). ACK is always generated by the receiving device. The MAX9729 generates an ACK when receiving a slave address or data by pulling SDA low during the ninth clock period. The SDA line must remain stable and low during the high period of the ACK clock pulse. When transmitting data, the MAX9729 waits for the receiving device to generate an ACK. Monitoring ACK allows detection of unsuccessful data transfers. An unsuccessful data transfer occurs if a receiving device is busy or if a system fault has occurred. In the event of an unsuccessful data transfer, the bus master should reattempt communication at a later time.

Write Data Format

A write to the MAX9729 includes transmission of a START condition, the slave address with the R/W bit set to 0 (see Table 1), one or two command bytes to configure the command registers, and a STOP condition. Figure 6a illustrates the proper data transmission for writing to register 0x00 in a single frame. Figure 6b illustrates the proper data transmission for writing to both registers 0x00 and 0x01 in a single frame.

As shown in Figures 6a and 6b, the MAX9729 communicates an ACK after each byte of information is received. The MAX9729 latches each command byte into the respective command registers after an ACK is communicated. The master device terminates the write data transmission by issuing a STOP condition.

When writing to register 0x01, register 0x00 must be written to first in the same data frame as shown in Figure 6b. In other words, when updating register 0x01 both registers must be written to.

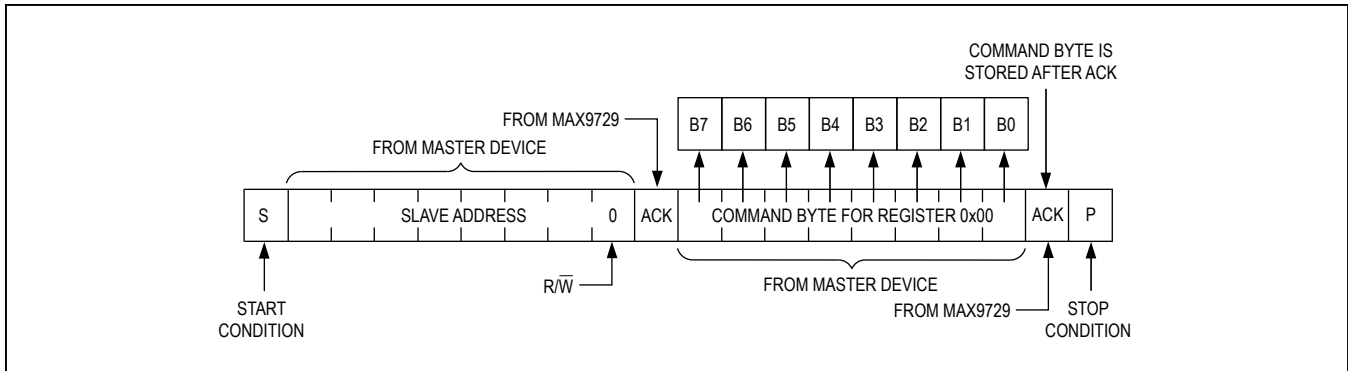

Figure 6a. Write Data Format for Writing to Register 0x00 Only

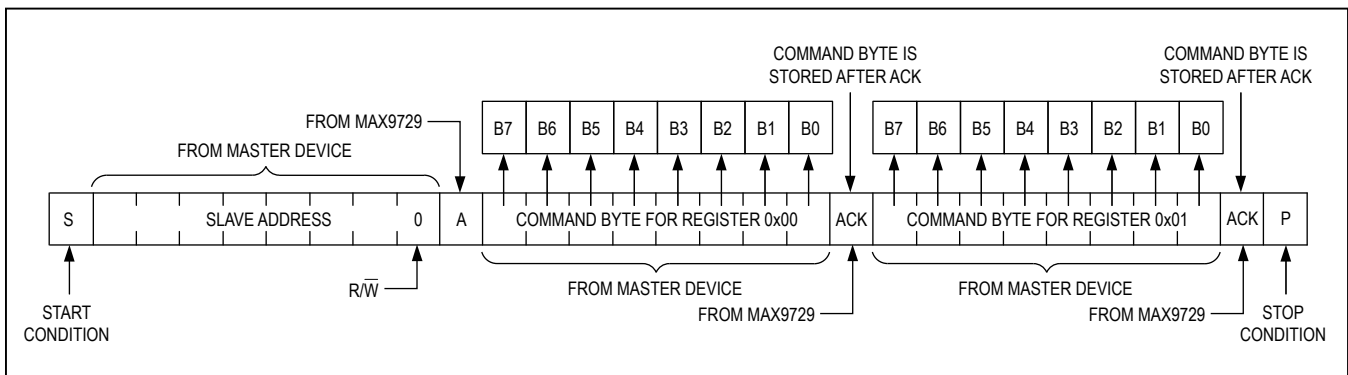

Figure 6b. Write Data Format for Writing to Registers 0x00 and 0x01

Read Data Format

A read from the MAX9729 includes transmission of a START condition, the slave address with the R/W bit set to 1, one or two bytes of register data sent by the MAX9729, and a STOP condition. Once the MAX9729 acknowledges the receipt of the slave address and R/W bit, the data direction of the SDA line reverses and the MAX9729 writes the contents of the command register 0x00 and 0x01 to the bus in that order. Each byte sent by the MAX9729 should be acknowledged by the master device unless the byte is the last data byte of the transmission, in which case, the master device should communicate a not acknowledge (NACK). After the NACK is communicated, the master device terminates the read data transmission by issuing a STOP condition. Figure 7a illustrates the proper data transmission for reading the contents of register 0x00. Figure 7b illustrates the proper data transmission for reading the contents of both registers 0x00 and 0x01 in a single frame. Data sent by the MAX9729 is valid on the rising edge of SCL.

When reading register 0x01, register 0x00 must be read first in the same data frame as shown in Figure 7b.

In other words, when reading register 0x01 both registers must be read.

Command Registers

The MAX9729 utilizes two command registers to enable/disable shutdown, control the multiplexer/mixer, set the volume, set the BEEP input attenuation, enable/disable BassMax, and set the maximum gain. Table 2 describes the function of the bits contained in the command registers.

Set B7 to 0 in register 0x00 to shut down the MAX9729. The MAX9729 exits shutdown when B7 is set to 1 provided SHDN is high. SHDN must be high and B7 must be set to 1 for the MAX9729 to operate normally (see Table 3).

Bits [6:5] in register 0x00 control the input multiplexer/mixer. Select the desired input path and enable mixing of all three stereo input sources with these bits (see Table 4).

Adjust the MAX9729's volume with bits [4:0] in register 0x00. The volume is adjustable to one of 32 steps ranging from full mute to the maximum gain set by bits [B2:B0] in register 0x01. Tables 5a, 5b, 5c list all the possible volume settings and resulting total voltage gains for the

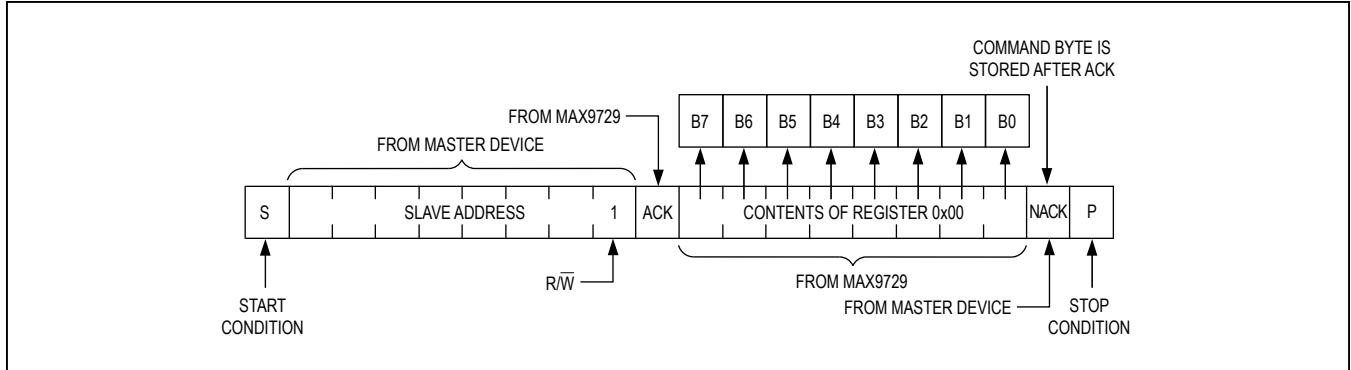

Figure 7a. Read Data Format for Reading Register 0x00 Only

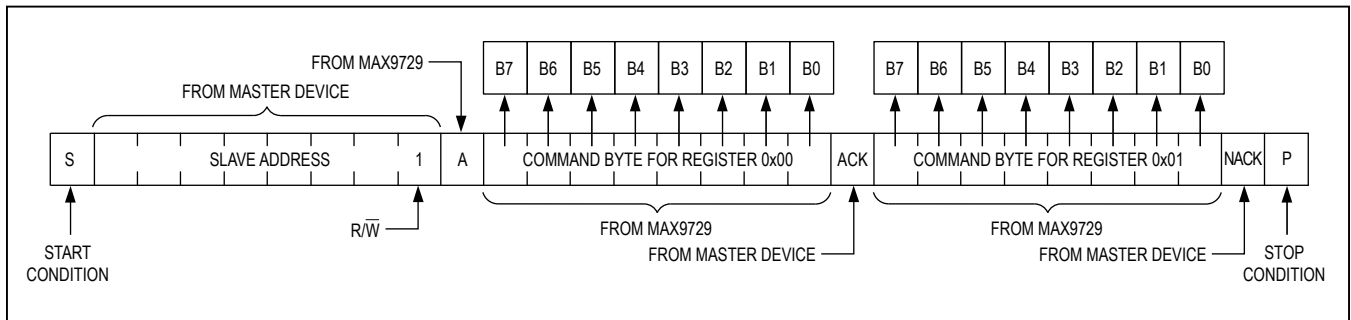

Figure 7b. Read Data Format for Reading Registers 0x00 and 0x01

Table 2. MAX9729 Command Registers

REGISTER	B7	B6	B5	B4	B3	B2	B1	B0
0x00	SHUTDOWN (see Table 3)	MUX/MIXER CONTROL (see Table 4)		VOLUME CONTROL (see Table 5)				
0x01	BEEP INPUT ATTENUATION (see Table 6)			1	BassMax ENABLE (see Table 7)	MAXIMUM GAIN CONTROL (see Table 8)		

X = Don't Care.

Table 3. Shutdown Control (Register 0x00), SHDN = VDD

B7	MODE
0	MAX9729 disabled
1	MAX9729 enabled

MAX9729. Figure 8 shows the volume control transfer function for the MAX9729.

Use bits [B7:B5] in register 0x01 to set the BEEP input attenuation. The BEEP input attenuation is adjustable to one of eight different values ranging from -10dB to -56dB (see Table 6).

Set B3 in register 0x01 to 1 to enable BassMax (see Table 7). The output signal's low-frequency response will be boosted according to the external components connected between OUT_ and BM_. See the *BassMax Gain-Setting Components* section for details on choosing the external components.

Use bits [2:0] in register 0x01 to set the maximum gain of the MAX9729 to one of eight different values ranging from +3.5dB to +26dB (see Table 8). The maximum gain setting in conjunction with the volume setting determines the overall voltage gain of the MAX9729 (see Tables 5a, 5b, 5c).

Table 4. Multiplexer/Mixer Control (Register 0x00)

B6	B5	OUTL	OUTR
0	0	INL1 x A _{V_TOTAL}	INR1 x A _{V_TOTAL}
0	1	INL2 x A _{V_TOTAL}	INR2 x A _{V_TOTAL}
1	0	INL3 x A _{V_TOTAL}	INR3 x A _{V_TOTAL}
1	1	(INL1 + INL2 + INL3) x A _{V_TOTAL}	(INR1 + INR2 + INR3) x A _{V_TOTAL}

Power-On Reset

The MAX9729 features internal power-on reset (POR) circuitry that initializes the device upon power-up. The contents of the MAX9729's command registers at power-on are shown in Table 9.

Applications Information**Power Dissipation and Heat Sinking**

Linear power amplifiers can dissipate a significant amount of power under normal operating conditions. The maximum power dissipation for each package is given in the Absolute Maximum Ratings section under Continuous Power Dissipation or can be calculated by the following equation:

$$P_{D(MAX)} = \frac{T_{J(MAX)} - T_A}{\theta_{JA}}$$

where $T_{J(MAX)}$ is +150°C, T_A is the ambient temperature, and θ_{JA} is the reciprocal of the derating factor in °C/W as specified in the *Absolute Maximum Ratings* section. For example, θ_{JA} for the thin QFN package is +35°C/W.

If the power dissipation exceeds the rated package dissipation, reduce V_{DD} , increase load impedance, decrease the ambient temperature, or add heatsinking. Large output, supply, and ground traces decrease θ_{JA} , allowing more heat to be transferred from the package to surrounding air.

Output Dynamic Range

Dynamic range is the difference between the noise floor of the system and the output level at 1% THD+N. It is essential that a system's dynamic range be known before setting the maximum output gain. Output clipping will occur if the output signal is greater than the dynamic range of the system. The DirectDrive architecture of the MAX9729 has increased dynamic range (for a given V_{DD}) compared to other single-supply amplifiers. Due to the absolute maximum ratings of the MAX9729 and to limit power dissipation, the MAX9729 includes internal circuitry that limits the output voltage to approximately ±2.5V.

Use the THD+N vs. Output Power graph in the *Typical Operating Characteristics* to identify the system's dynamic range. Find the output power that causes 1% THD+N for a given load. This point will indicate what output power causes the output to begin to clip. Use the following equation to determine the peak-to-peak output voltage that causes 1% THD+N for a given load:

$$V_{OUT_(P-P)} = 2\sqrt{2(P_{OUT_1\%} \times R_L)}$$

where $P_{OUT_1\%}$ is the output power that causes 1% THD+N, R_L is the load resistance, and $V_{OUT_(P-P)}$ is the peak-to-peak output voltage. Determine the total voltage gain (A_{V_TOTAL}) necessary to attain this output voltage based on the maximum peak-to-peak input voltage ($V_{IN_(P-P)}$):

$$A_{V_TOTAL} = \frac{V_{OUT_(P-P)}}{V_{IN_(P-P)}}$$

The A_{V_TOTAL} setting is determined by the maximum voltage gain setting, volume setting, and bass boost gain if BassMax is enabled (see the *Maximum Gain Control, Volume Control, and BassMax Gain-Setting Components* sections).

UVLO

The MAX9729 features an undervoltage lockout (UVLO) function that prevents the device from operating if the supply voltage is less than 1.65V. This feature ensures proper operation during brownout conditions and prevents deep battery discharge. Once the supply voltage exceeds the UVLO threshold, the MAX9729 charge pump is turned on, the amplifiers are powered (provided that \overline{SHDN} is high), and the command registers are reset to their POR values (see Table 9).

Component Selection**Charge-Pump Capacitor Selection**

Use ceramic capacitors with a low ESR for optimum performance. For optimal performance over the extended temperature range, select capacitors with an X7R dielectric.

Table 5a. Volume Control (Register 0x00)

B4	B3	B2	B1	B0	ATTEN FROM MAX GAIN SETTING (dB)	AV_TOTAL (dB)		
						WITH AV_MAX = +3.5dB	WITH AV_MAX = +6dB	WITH AV_MAX = +8dB
0	0	0	0	0	-0	+3.5	+6	+8
0	0	0	0	1	-1.7	+1.8	+4.3	+6.3
0	0	0	1	0	-3.4	+0.1	+2.6	+4.6
0	0	0	1	1	-4.8	-1.3	+1.2	+3.2
0	0	1	0	0	-6.2	-2.7	-0.2	+1.8
0	0	1	0	1	-7.6	-4.1	-1.6	+0.4
0	0	1	1	0	-9	-5.5	-3	-1
0	0	1	1	1	-10.4	-6.9	-4.4	-2.4
0	1	0	0	0	-11.8	-8.3	-5.8	-3.8
0	1	0	0	1	-13.2	-9.7	-7.2	-5.2
0	1	0	1	0	-14.6	-11.1	-8.6	-6.6
0	1	0	1	1	-16	-12.5	-10	-8
0	1	1	0	0	-17.4	-13.9	-11.4	-9.4
0	1	1	0	1	-18.8	-15.3	-12.8	-10.8
0	1	1	1	0	-20.2	-16.7	-14.2	-12.2
0	1	1	1	1	-21.6	-18.1	-15.6	-13.6
1	0	0	0	0	-23.1	-19.6	-17.1	-15.1
1	0	0	0	1	-24.4	-20.9	-18.4	-16.4
1	0	0	1	0	-26	-22.5	-20	-18
1	0	0	1	1	-27.1	-23.6	-21.1	-19.1
1	0	1	0	0	-28.6	-25.1	-22.6	-20.6
1	0	1	0	1	-30.1	-26.6	-24.1	-22.1
1	0	1	1	0	-32.3	-28.8	-26.3	-24.3
1	0	1	1	1	-35.1	-31.6	-29.1	-27.1
1	1	0	0	0	-38.6	-35.1	-32.6	-30.6
1	1	0	0	1	-42.1	-38.6	-36.1	-34.1
1	1	0	1	0	-46.2	-42.7	-40.2	-38.2
1	1	0	1	1	-50.7	-47.2	-44.7	-42.7
1	1	1	0	0	-54.2	-50.7	-48.2	-46.2
1	1	1	0	1	-60.2	-56.7	-54.2	-52.2
1	1	1	1	0	-70	-66.5	-64	-62
1	1	1	1	1	MUTE	MUTE	MUTE	MUTE

Table 5b. Volume Control (Register 0x00)

B4	B3	B2	B1	B0	ATTEN FROM MAX GAIN SETTING (dB)	AV_TOTAL (dB)		
						WITH AV_MAX = +10dB	WITH AV_MAX = +19.5dB	WITH AV_MAX = +22dB
0	0	0	0	0	-0	+10	+19.5	+22
0	0	0	0	1	-1.7	+8.3	+17.8	+20.3
0	0	0	1	0	-3.4	+6.6	+16.1	+18.6
0	0	0	1	1	-4.8	+5.2	+14.7	+17.2
0	0	1	0	0	-6.2	+3.8	+13.3	+15.8
0	0	1	0	1	-7.6	+2.4	+11.9	+14.4
0	0	1	1	0	-9	+1	+10.5	+13
0	0	1	1	1	-10.4	-0.4	+9.1	+11.6
0	1	0	0	0	-11.8	-1.8	+7.7	+0.2
0	1	0	0	1	-13.2	-3.2	+6.3	+8.8
0	1	0	1	0	-14.6	-4.6	+4.9	+7.4
0	1	0	1	1	-16	-6	+3.5	+6
0	1	1	0	0	-17.4	-7.4	+2.1	+4.6
0	1	1	0	1	-18.8	-8.8	+0.7	+3.2
0	1	1	1	0	-20.2	-10.2	-0.7	+1.8
0	1	1	1	1	-21.6	-11.6	-2.1	+0.4
1	0	0	0	0	-23.1	-13.1	-3.6	-1.1
1	0	0	0	1	-24.4	-14.4	-4.9	-2.4
1	0	0	1	0	-26	-16	-6.5	-4
1	0	0	1	1	-27.1	-17.1	-7.6	-5.1
1	0	1	0	0	-28.6	-18.6	-9.1	-6.6
1	0	1	0	1	-30.1	-20.1	-10.6	-8.1
1	0	1	1	0	-32.3	-22.3	-12.8	-10.3
1	0	1	1	1	-35.1	-25.1	-15.6	-13.1
1	1	0	0	0	-38.6	-28.6	-19.1	-16.6
1	1	0	0	1	-42.1	-32.1	-22.6	-20.1
1	1	0	1	0	-46.2	-36.2	-26.7	-24.2
1	1	0	1	1	-50.7	-40.7	-31.2	-28.7
1	1	1	0	0	-54.2	-44.2	-34.7	-32.2
1	1	1	0	1	-60.2	-50.2	-40.7	-38.2
1	1	1	1	0	-70	-60	-50.5	-48
1	1	1	1	1	MUTE	MUTE	MUTE	MUTE

Table 5c. Volume Control (Register 0x00)

B4	B3	B2	B1	B0	ATTEN FROM MAX GAIN SETTING (dB)	A _V _TOTAL (dB)	
						WITH A _V _MAX = +24dB	WITH A _V _MAX = +26dB
0	0	0	0	0	-0	+24	+26
0	0	0	0	1	-1.7	+22.3	+24.3
0	0	0	1	0	-3.4	+20.6	+22.6
0	0	0	1	1	-4.8	+19.2	+21.2
0	0	1	0	0	-6.2	+17.8	+19.8
0	0	1	0	1	-7.6	+16.4	+18.4
0	0	1	1	0	-9	+15	+17
0	0	1	1	1	-10.4	+13.6	+15.6
0	1	0	0	0	-11.8	+12.2	+14.2
0	1	0	0	1	-13.2	+10.8	+12.8
0	1	0	1	0	-14.6	+9.4	+11.4
0	1	0	1	1	-16	+8	+10
0	1	1	0	0	-17.4	+6.6	+8.6
0	1	1	0	1	-18.8	+5.2	+7.2
0	1	1	1	0	-20.2	+3.8	+5.8
0	1	1	1	1	-21.6	+2.4	+4.4
1	0	0	0	0	-23.1	+0.9	+2.9
1	0	0	0	1	-24.4	-0.4	+1.6
1	0	0	1	0	-26	-2	+0
1	0	0	1	1	-27.1	-3.1	-1.1
1	0	1	0	0	-28.6	-4.6	-2.6
1	0	1	0	1	-30.1	-6.1	-4.1
1	0	1	1	0	-32.3	-8.3	-6.3
1	0	1	1	1	-35.1	-11.1	-9.1
1	1	0	0	0	-38.6	-14.6	-12.6
1	1	0	0	1	-42.1	-18.1	-16.1
1	1	0	1	0	-46.2	-22.2	-20.2
1	1	0	1	1	-50.7	-26.7	-24.7
1	1	1	0	0	-54.2	-30.2	-28.2
1	1	1	0	1	-60.2	-36.2	-34.2
1	1	1	1	0	-70	-46	-44
1	1	1	1	1	MUTE	MUTE	MUTE

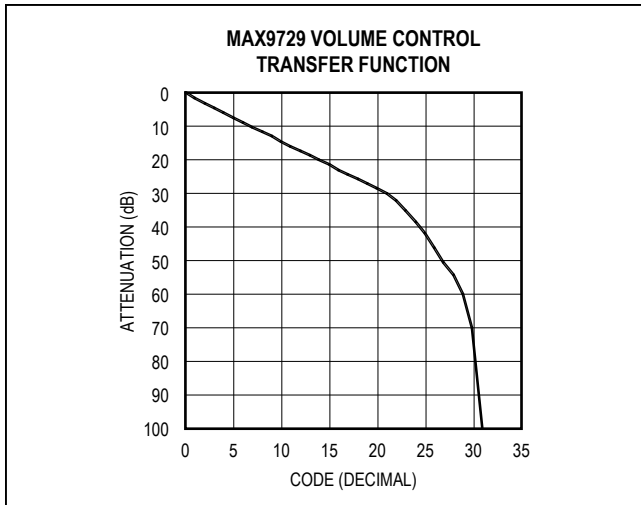

Figure 8. MAX9729 Volume Control Transfer Function

Table 6. Beep Level (Register 0x01)

B7	B6	B5	BEEP LEVEL (dBV)
0	0	0	-10
0	0	1	-20
0	1	0	-30
0	1	1	-40
1	0	0	-50
1	0	1	-52
1	1	0	-54
1	1	1	-56

BEEP level referenced to a 3V BEEP input.

Charge-Pump Flying Capacitor (C1)

The charge-pump flying capacitor connected between C1N and C1P affects the charge pump’s load regulation and output impedance. Choosing too small a flying capacitor degrades the MAX9729’s ability to provide sufficient current drive and leads to a loss of output voltage. Increasing the value of the flying capacitor improves load regulation and reduces the chargepump output impedance. See the Output Power vs. Charge-Pump Capacitance and Load Resistance graph in the *Typical*

Table 7. BassMax Control (Register 0x01)

B3	MODE
0	BassMax Disabled
1	BassMax Enabled

Table 8. Maximum Gain Control (Register 0x01)

B2	B1	B0	MAXIMUM GAIN (dB)
0	0	0	3.5
0	0	1	6
0	1	0	8
0	1	1	10
1	0	0	19.5
1	0	1	22
1	1	0	24
1	1	1	26

Operating Characteristics. Place C1 physically close to C1P and C1N. Use a 1µF capacitor for C1 in most applications.

Charge-Pump Hold Capacitor (C2)

The hold capacitor’s value and ESR directly affect the ripple at PVSS. Ripple is reduced by increasing the value of the hold capacitor. Choosing a capacitor with lower ESR reduces ripple and output impedance. Lower capacitance values can be used in systems with low maximum output power levels. See the Output Power vs. Charge-Pump Capacitance and Load Resistance graph in the *Typical Operating Characteristics*. C2 should be equal to the value of C1. Place C2 physically close to PVSS and SVSS. Connect PVSS and SVSS together at C2. Use a 1µF capacitor for C2 in most applications.

PVDD Bypass Capacitor (C3)

The PVDD bypass capacitor lowers the output impedance of the power supply and reduces the impact of the MAX9729’s charge-pump switching transients. C3 should be greater than or equal to C1. Place C3 physically close to PVDD.

Table 9. Initial Power-Up Command Register Status

REGISTER	B7	B6	B5	B4	B3	B2	B1	B0	POR SETTINGS
0x00	1	0	0	0	1	0	1	1	Shutdown mode disabled (assuming V _{SHDN} = V _{DD}), INL1 and INR1 inputs selected, ATTEN = 16dB (A _{V_TOTAL} = -10dB)
0x01	1	1	1	1	1	0	0	1	Beep input attenuation = 56dB, BassMax enabled, A _{V_MAX} = 6dB

Input-Coupling Capacitor

The AC-coupling capacitor (C_{IN}) and input resistor (R_{IN}) form a highpass filter that removes any DC bias from an input signal. See the *Functional Diagram/Typical Operating Circuit*. C_{IN} prevents any DC components from the input signal source from appearing at the amplifier outputs. The -3dB point of the highpass filter, assuming zero source impedance due to the input signal source, is given by:

$$f_{-3dB} = \frac{1}{2\pi \times R_{IN} \times C_{IN}} \text{ (Hz)}$$

Choose C_{IN} such that f_{-3dB} is well below the lowest frequency of interest. Setting f_{-3dB} too high affects the amplifier’s low-frequency response. Use capacitors with low-voltage coefficient dielectrics. Aluminum electrolytic, tantalum, or film dielectric capacitors are good choices for AC-coupling capacitors. Capacitors with high-voltage coefficients, such as ceramics (non-C0G dielectrics), can result in increased distortion at low zero frequencies. If a ceramic capacitor is selected due to board space or cost constraints, use the largest package possible to minimize voltage coefficient effects. In addition, use X7R dielectrics as opposed to X5R, Y5V, or Z5U.

BassMax Gain-Setting Components

The bass boost, low-frequency response when BassMax is enabled, is set by the ratio of R1 to R2 (see Figure 2), by the following equation:

$$A_{V_BOOST} = 20 \times \log \frac{R1+R2}{R1-R2} \text{ (dB)}$$

where A_{V_BOOST} is the gain boost, in dB, at low frequencies. A_{V_BOOST} is added to the gain realized by the maximum gain setting and the volume setting. The total gain at low frequencies is equal to:

$$A_{V_TOTAL_BM} = A_{V_MAX} - ATTEN + A_{V_BOOST} \text{ (dB)}$$

where A_{V_TOTAL_BM} is the total voltage gain at low frequencies in dB, A_{V_MAX} is the maximum gain setting in dB, and ATTEN is the volume attenuation in dB. To maintain circuit stability, the ratio:

$$\frac{R2}{R1+R2}$$

must not exceed 1/2. A ratio equaling 1/3 is recommended. The switch that shorts BM₋ to SGND, when BassMax is disabled, can have an on-resistance as high as 300Ω.

Choose a value for R1 that is greater than 40kΩ to ensure that positive feedback is negligible when BassMax is

Table 10. BassMax Gain Examples, R1 = 47kΩ

R2 (kΩ)	A _{V_BOOST} (dB)
39	20.6
33	15.1
27	11.3
22	8.8
15	5.7
10	3.7

disabled. Table 10 contains a list of R2 values, with R1 = 47kΩ, and the corresponding low-frequency gain boost values.

The low-frequency boost attained by the BassMax circuit is added to the gain realized by the maximum gain setting and volume setting. Select the BassMax gain so that the output signal will remain within the dynamic range of the MAX9729. Output signal clipping will occur at low frequencies if the BassMax gain boost is excessively large. See the *Output Dynamic Range* section.

Capacitor C4 forms a pole and a zero according to the following equations:

$$f_{POLE} = \frac{R1-R2}{2\pi \times C6 \times R1 \times R2} \text{ (Hz)}$$

$$f_{ZERO} = \frac{R1+R2}{2\pi \times C6 \times R1 \times R2} \text{ (Hz)}$$

f_{POLE} is the frequency at which the gain boost begins to roll off. f_{POLE} is the frequency at which the bass boost gain no longer affects the transfer function. At frequencies greater than or equal to f_{POLE}, the gain set by the maximum gain setting and the volume control attenuation dominate. Table 11 contains a list of capacitor values and the corresponding poles and zeros for a given DC gain. See Figure 9 for an example of a gain profile using BassMax.

Layout and Grounding

Proper layout and grounding are essential for optimum performance. Connect PGND and SGND together at a single point (star ground point) on the PCB near the MAX9729. Connect PV_{SS} and SV_{SS} together at C2. Place C2 physically close to PV_{SS} and SV_{SS} and connect it to PGND. Bypass PV_{DD} to PGND with C3. Connect C3 as close to PV_{DD} as possible. Bypass V_{DD} to SGND with a 1μF capacitor. Place the V_{DD} bypass capacitor as close to V_{DD} as possible. Route PGND and all traces that carry

Table 11. BassMax Pole and Zero Examples for a Gain Boost of 8.8dB (R1 = 47kΩ, R2 = 22kΩ)

C6 (nF)	f _{POLE} (Hz)	f _{ZERO} (Hz)
100	38	106
82	47	130
68	56	156
56	68	190
47	81	230
22	174	490
10	384	1060

switching transients away from SGND and the audio signal path. Route digital signal traces away from the audio signal path. Make traces perpendicular to each other when routing digital signals over or under audio signals.

The thin QFN package features an exposed paddle that improves thermal efficiency. **Ensure that the exposed paddle is electrically isolated from PGND, SGND, and V_{DD}. Connect the exposed paddle to SV_{SS} when the board layout dictates that the exposed paddle cannot be left unconnected.**

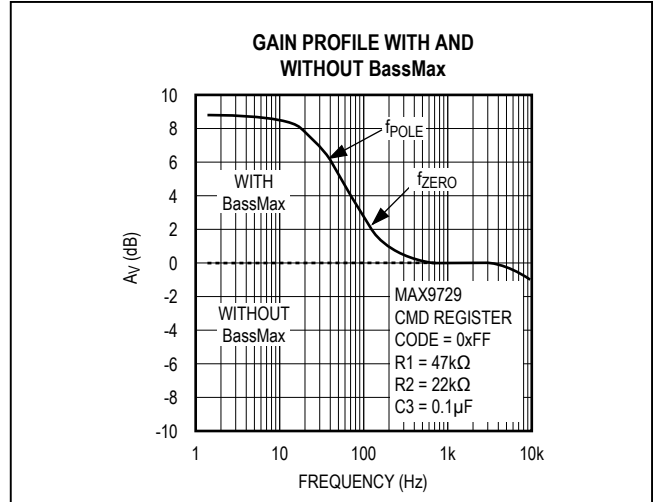
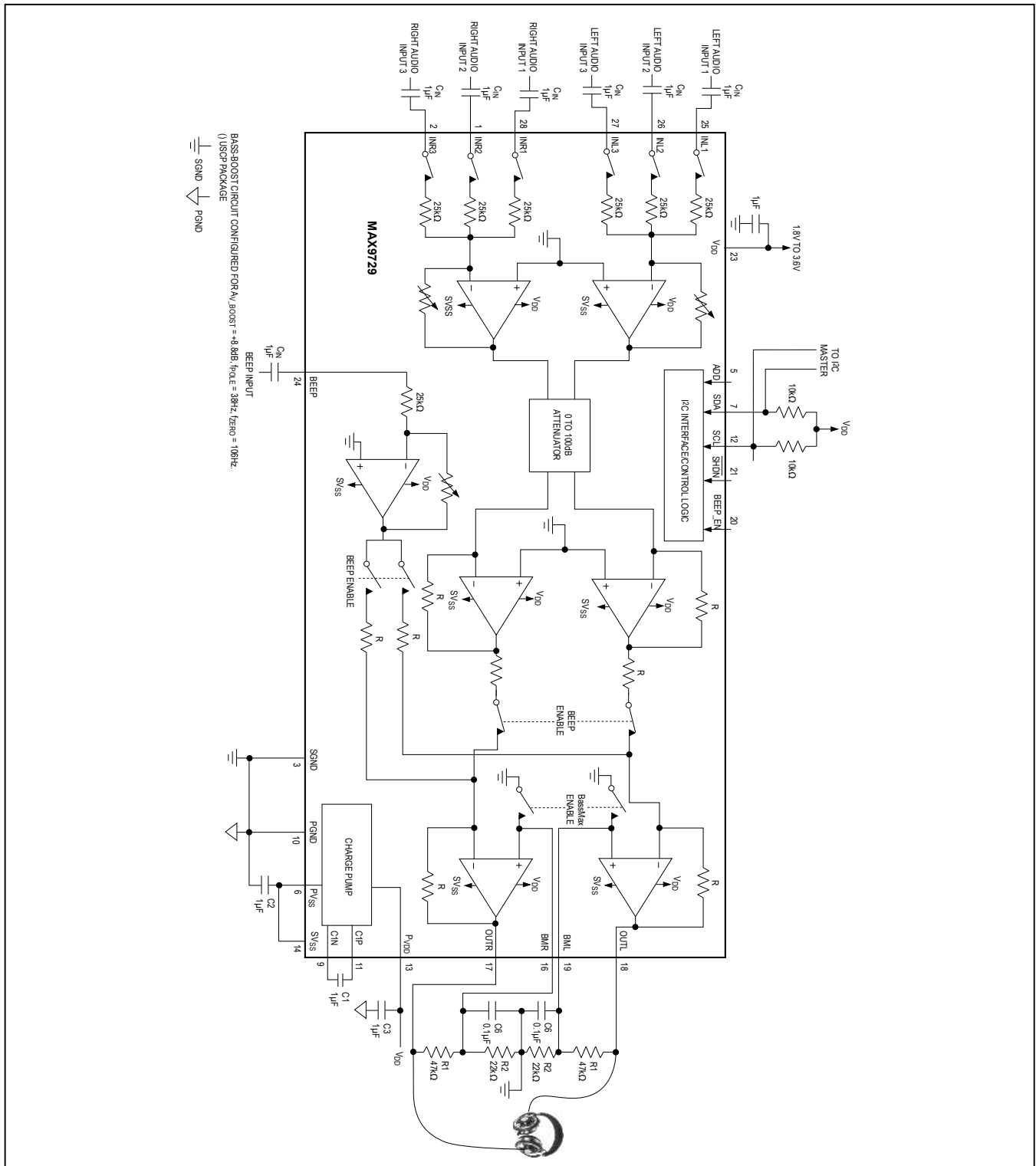
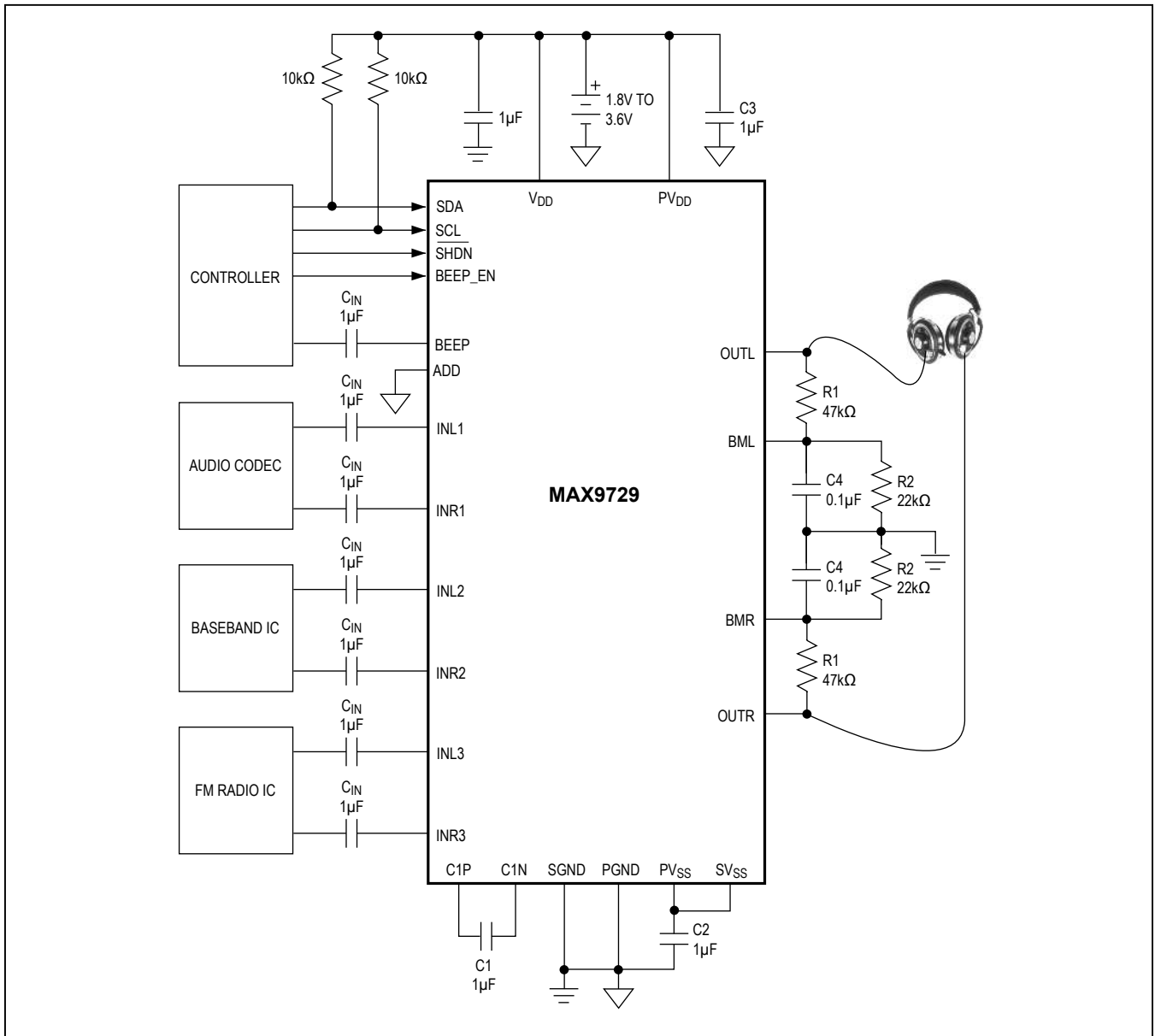

Figure 9. BassMax Gain Profile Example

Functional Diagram/Typical Operating Circuit



System Diagram



Pin Configuration

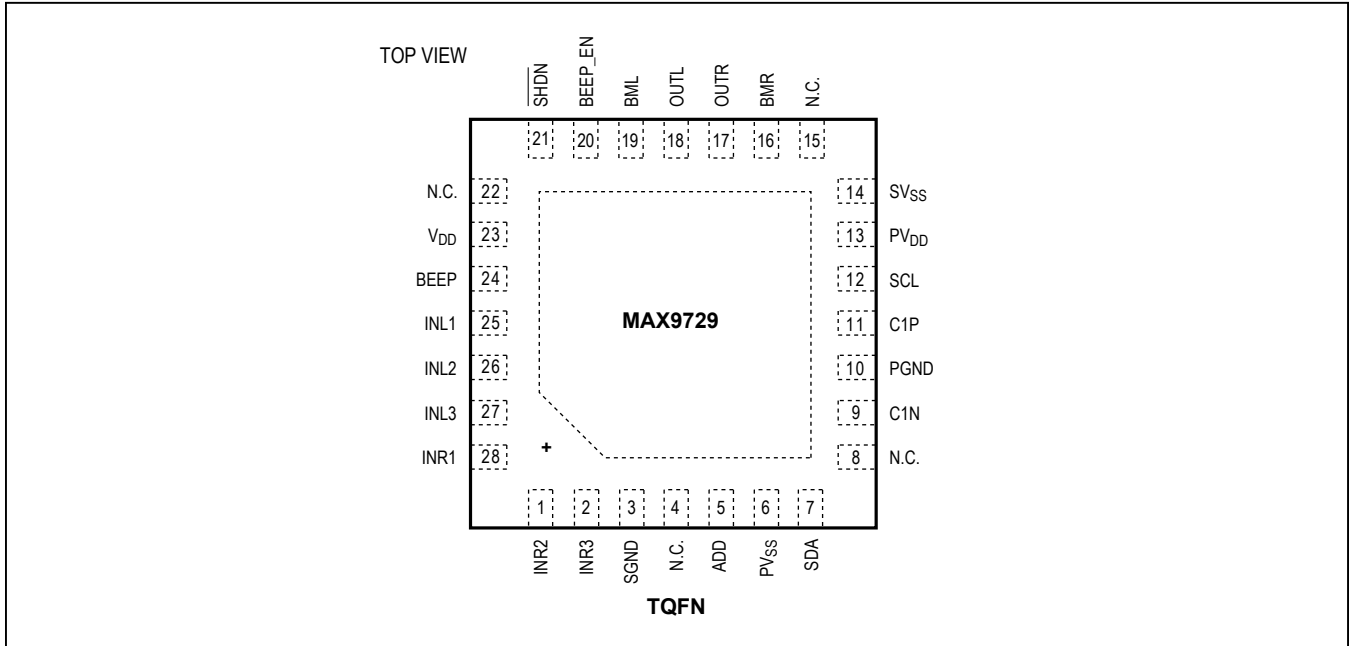

Chip Information

PROCESS: BiCMOS

Package Information

For the latest package outline information and land patterns (footprints), go to www.maximintegrated.com/packages. Note that a “+”, “#”, or “-” in the package code indicates RoHS status only. Package drawings may show a different suffix character, but the drawing pertains to the package regardless of RoHS status.

PACKAGE TYPE	PACKAGE CODE	OUTLINE NO.	LAND PATTERN NO.
28 TQFN-EP	T2855-5	21-0140	90-0025

MAX9729

Stereo Headphone Amplifier with BassMax,
Volume Control, and Input Mux

Revision History

REVISION NUMBER	REVISION DATE	DESCRIPTION	PAGES CHANGED
0	7/07	Initial release	—
1	5/14	Removed automotive reference from <i>Applications</i> section	1

For pricing, delivery, and ordering information, please contact Maxim Direct at 1-888-629-4642, or visit Maxim Integrated's website at www.maximintegrated.com.

Maxim Integrated cannot assume responsibility for use of any circuitry other than circuitry entirely embodied in a Maxim Integrated product. No circuit patent licenses are implied. Maxim Integrated reserves the right to change the circuitry and specifications without notice at any time. The parametric values (min and max limits) shown in the Electrical Characteristics table are guaranteed. Other parametric values quoted in this data sheet are provided for guidance.