

PART NUMBER	REV	FIRST USED
680696-1	A	122500-1
680696-2	A	565435-5
680696-3	A	354500-1

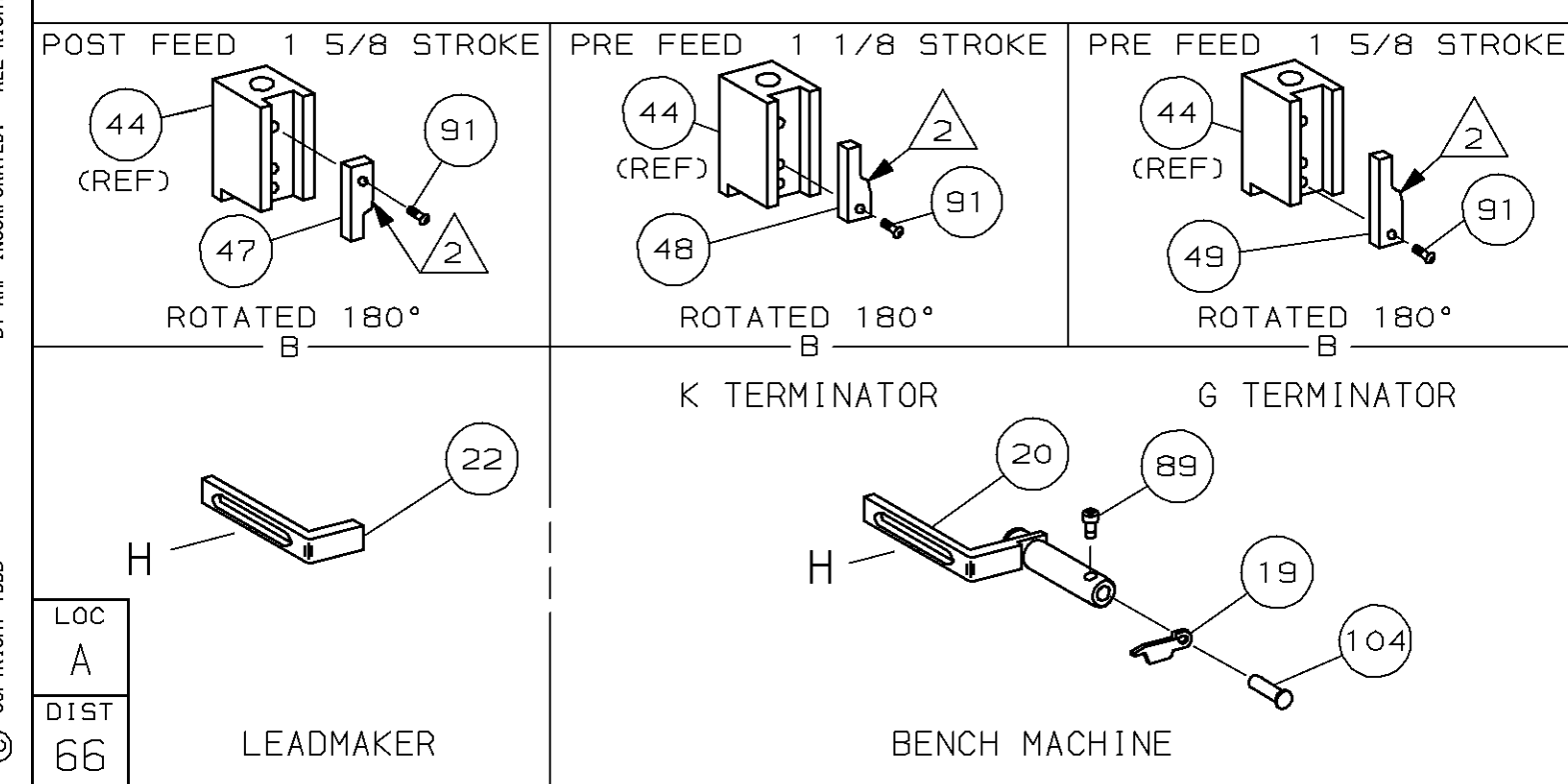
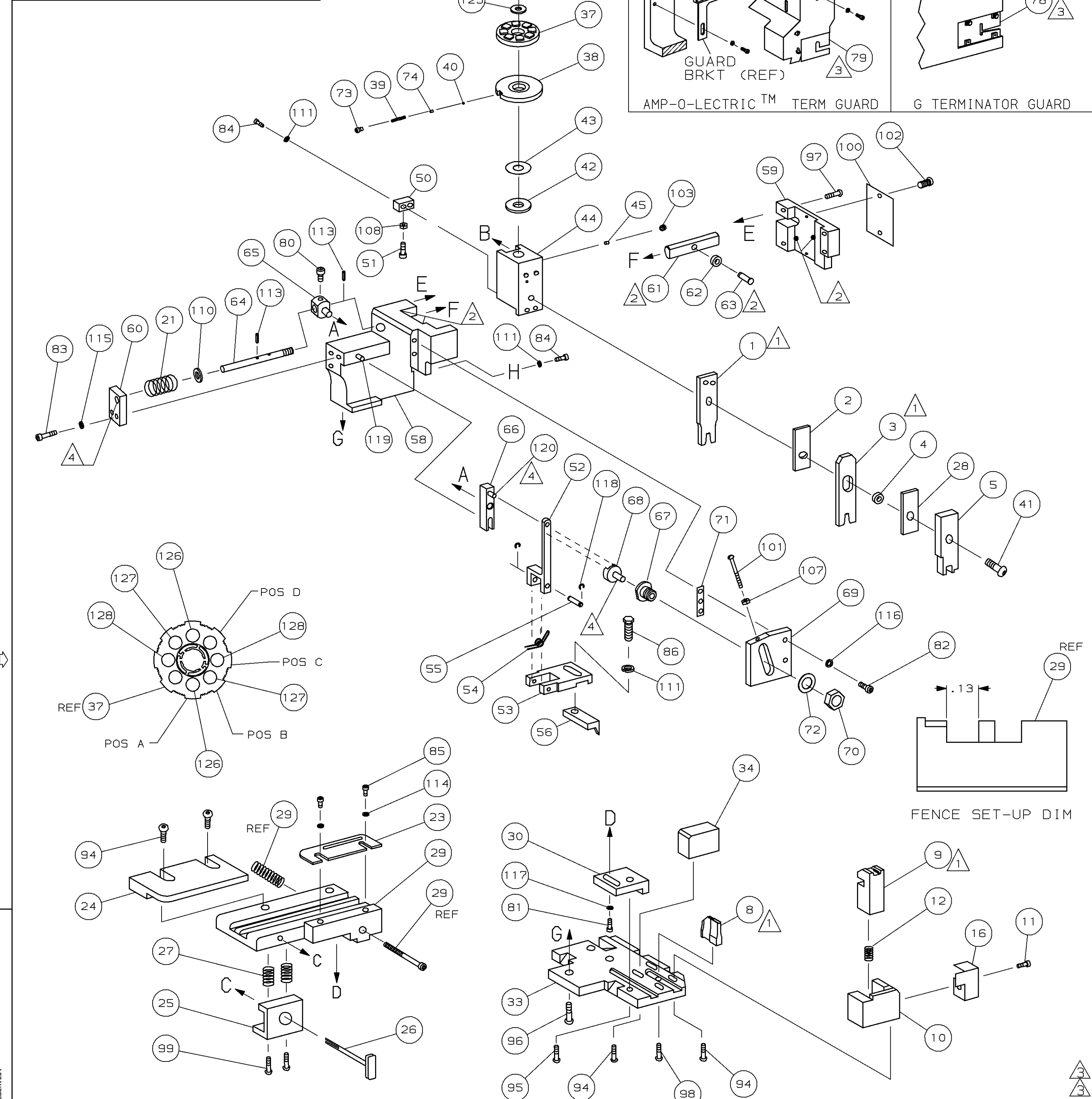

- 1 RECOMMENDED SPARE PARTS.
- 2 GREASE LIGHTLY.
- 3 GUARD MUST BE IN PLACE WHEN OPERATING APPLICATOR IN A BENCH MACHINE.
- 4 LUBRICATE DAILY USING NO. 20 MACHINE OIL.
- 5. ITEMS WITH QTY OF REF SPECIFIED (EXCEPT ITEMS 78 AND 79) ARE USED ON ITEM 46.
- 6 GUIDE OFF INSULATION BARREL

CRIMP DATA (AMP TERMINAL)			
PAD LTR	CRIMP HEIGHT	WIRE SIZE	
A	.042 ±.002 [1.07 ±0.05mm]	22 (0.35mm ²)	
B	.040 ±.002 [1.02 ±0.05mm]	24 (0.25mm ²)	
C	.039 ±.002 [0.99 ±0.05mm]	24 (0.20mm ²)	
D	NOT	USED	
CRIMP	SIZE	TYPE	RANGE
WIRE	.070 [1.78mm]	F	24-22
INSUL	.090 [2.29mm]	OV	.043-.051

QTY REQD PER ASSY	TERM	APPL	SPEC	FEED	APPL INSTRUCTION	SET UP GAGE	LAYOUT	ITEM NO
2	2	2	-	C	5-354779-4	PIN, WIRE DISC (.3260)C		129
2	2	2	-	C	5-354779-2	PIN, WIRE DISC (.3250)B		127
2	2	2	-	C	4-354779-8	PIN, WIRE DISC (.3230)A		126
1	1	1	-	A	986950-1	WASHER, FLAT PRECISION		125
1	1	1	-	A	217238-1	GENERAL INSTRUCTION PACKAGE		124
1	1	1	-	-	4088040	SF APPL INST 408-8040		123
								122
								121
REF	REF	REF	-	A	1-21030-1	PIN, DOWEL (Ø.187x.50) LEVER		120
REF	REF	REF	-	A	1-21030-6	PIN, DOWEL (Ø.187x1.25) HOUSING		119
REF	REF	REF	-	A	21045-3	RING, RET "C" (Ø.187) FD FING PIN		118
1	1	1	-	A	21024-5	WASHER, LOCK (#10) ADJ BLOCK		117
REF	REF	REF	-	A	21024-5	WASHER, LOCK (#10) ADJ PLATE		116
REF	REF	REF	-	A	21024-5	WASHER, LOCK (#10) FEED GDE ROD		115
2	2	2	-	A	21024-2	WASHER, LOCK (#4) FRONT STP GUIDE		114
REF	REF	REF	-	A	5-21028-1	PIN, SLT SPR (Ø.125x.50) ADJ ROD		113
								112
4	4	4	-	A	21024-4	WASHER, LOCK (#8) STRIPPER		111
REF	REF	REF	-	A	21899-4	WASHER, FLAT (Ø5/16) SCREW ADJ		110
								109
1	1	1	-	A	21018-5	NUT, HEX (NO. 6) HOLDDOWN		108
REF	REF	REF	-	A	21068-5	NUT, HEX (6-32) FEED ADJ		107
								106
								105
1	1	-	-	A	992031-1	PIN, CLEVIS		104
1	1	1	-	A	21009-2	SCR, SKT SET (1/4-20x.25 LW) RAM		103
2	2	2	-	A	21017-2	SCR, DRIVE (#2x.19) ID PLATE		102
REF	REF	REF	-	A	6-23715-5	SCR, PAN HD (6-32x1.50) FEED ADJ		101
1	1	1	-	B	461264-1	PLATE, IDENTIFICATION		100
2	2	2	-	A	3-21002-0	SCR, BHC (10-32x.88) DRAG		99
1	1	1	-	A	22733-8	SCR, BHC (8-32x.38 LW) ANVIL		98
REF	REF	REF	-	A	2-21002-9	SCR, BHC (10-32x.75) CAP		97
REF	REF	REF	-	A	2-22733-8	SCR, BHC (1/4-20x.62) HOUSING		96
REF	REF	REF	-	A	2-21002-7	SCR, BHC (10-32x.50) SG ADJ BLOCK		95
6	6	6	-	A	2-21002-2	SCR, BHC (8-32x.50) TERM H DWN		94
								93
								92
1	1	1	-	A	1-21002-7	SCR, BHC (6-32x.38) CAM		91
								90
1	1	-	-	A	7-21000-9	SCR, SHC (4-40x.19) STRIPPER		89
								88
								87
1	1	1	-	A	2-22603-0	SCR, HEX HD (8-32x.31) FEED FINGER		86
2	2	2	-	A	1-21000-3	SCR, SHC (4-40x.25) F ST GUIDE		85
3	3	3	-	A	2-21000-7	SCR, SHC (8-32x.50) STRIPPER		84
REF	REF	REF	-	A	3-21000-7	SCR, SHC (10-32x.75) FEED ROD GD		83
REF	REF	REF	-	A	3-21000-6	SCR, SHC (10-32x.62) FD ADJ BLK		82
1	1	1	-	A	3-21000-4	SCR, SHC (10-32x.38) SG ADJ BL		81
REF	REF	REF	-	A	3-21000-4	SCR, SHC (10-32x.38) PIVOT BLK		80
-	REF	-	-	B	455749-1	GUARD, WINDOW		79
REF	-	-	-	B	679532-1	INSERT, GUARD		78
								77
								76
								75
1	1	1	-	A	690603-1	SPRING, ASSIST		74
1	1	1	-	A	23030-1	SCR, SHC (6-32x.25 SL) INS DISC		73
REF	REF	REF	-	A	458109-1	WASHER, SPECIAL		72
REF	REF	REF	-	A	690517-1	SPACER		71
-3	-2	-1	U/M	DWG SIZE	PART NO	DESCRIPTION		ITEM NO

QTY REQD PER ASSY	TERM	APPL	SPEC	FEED	APPL INSTRUCTION	SET UP GAGE	LAYOUT	ITEM NO
-1								70
-2								69
-3								68
REF	REF	REF	-	B	22594-8	NUT, HEX (1/2-20)		67
REF	REF	REF	-	B	240628-1	PLATE, ADJUSTMENT		66
REF	REF	REF	-	B	240626-1	SHAFT, PIVOT		65
REF	REF	REF	-	B	240633-1	BUSHING		64
REF	REF	REF	-	A	455680-1	LEVER, INTERMEDIATE		63
REF	REF	REF	-	B	240629-1	BLOCK, PIVOT		62
REF	REF	REF	-	A	240632-2	SCREW, ADJ FEED ROD		61
REF	REF	REF	-	B	240659-3	PIN, CAM ROLLER		60
REF	REF	REF	-	B	240658-1	ROLLER, CAM		59
REF	REF	REF	-	B	454398-2	ROD, FEED		58
REF	REF	REF	-	A	454178-1	GUIDE, FEED ROD		57
REF	REF	REF	-	C	454220-1	CAP, RAM		56
REF	REF	REF	-	D	454485-1	HOUSING		55
								54
1	1	1	-	B	1-694433-6	PAWL, FEED		53
REF	REF	REF	-	B	240624-1	PIN, FEED FINGER		52
REF	REF	REF	-	B	691499-1	SPRING, FEED FINGER		51
REF	REF	REF	-	B	690541-1	HOLDER, FEED FINGER		50
REF	REF	REF	-	A	455679-2	LEVER, TERMINAL FEED ARM		49
1	1	1	-	A	811242-2	BUMPER, HOLDDOWN		48
1	1	1	-	A	690753-1	SPACER, TONKER		47
1	-	-	-	B	690602-6	CAM, PRE-FEED 1 5/8 ST		46
-	1	-	-	B	690602-5	CAM, PRE-FEED 1 1/8 ST		45
-	-	-	-	B	690501-4	CAM, POST-FEED 1 5/8 ST		44
1	1	1	-	B	459456-2	APPLICATOR, BASIC (SUBASSY)		43
1	1	1	-	A	690191-1	PLUG, NYLON		42
1	1	1	-	C	455673-1	RAM		41
1	1	1	-	A	690125-1	WASHER, LAMINATED		40
1	1	1	-	A	690124-1	WASHER, RAM		39
1	1	1	-	A	7-21002-9	BOLT, CRIMPER (5/16x1.00)		38
1	1	1	-	A	23241-6	BALL, STEEL		37
1	1	1	-	A	690170-1	SPRING, COMPRESSION		36
1	1	1	-	C	690142-1	DISC, INSULATION		35
1	1	1	-	D	354777-1	WIRE DISC, PLASTIC		34
1	1	1	-	A	22480-5	WASHER, SPRING		33
1	1	1	-	B	690212-1	POST, RAM		32
1	1	1	-	B	690786-4	SUPPORT, TERMINAL		31
REF	REF	REF	-	D	455675-1	PLATE, BASE		30
								29
								28
REF	REF	REF	-	B	455689-1	BLOCK, STRIP GUIDE ADJ		27
1	1	1	-	C	318756-1	STRIP GUIDE PLATE ASSY		26
1	1	1	-	C	2-455888-4	SPACER, FRONT SHEAR DEP		25
1	1	1	-	C	1-22284-0	SPRING, DRAG		24
2	2	2	-	A	690546-1	LEVER, DRAG RELEASE		23
1	1	1	-	B	240792-1	DRAG, TERMINAL		22
1	1	1	-	D	1-90765-3	GUIDE, STRIP (REAR)		21
1	1	1	-	A	690438-1	GUIDE, STRIP (FRONT)		20
-	-	1	-	B	690472-2	STRIPPER		19
REF	REF	REF	-	A	4-22284-9	SPRING, FEED RETURN		18
1	1	-	-	A	679218-1	STRIPPER WIRE STOP ASSY		17
1	1	-	-	B	458949-1	STRIPPER		16
								15
								14
								13
1	1	1	-	A	5-22280-0	SPRING, SHEAR		12
1	1	1	-	B	690461-1	STOP, SHEAR		11
1	1	1	-	C	690459-1	HOLDER, SHEAR (FRONT)		10
1	1	1	-	C	1-454276-9	SHEAR, FLOAT (FRONT)		9
1	1	1	-	C	1-662185-9	ANVIL		8
								7
								6
1	1	1	-	C	1-455889-4	DEPRESSOR, SHEAR (FRONT)		5
1	1	1	-	B	238011-4	SPACER, BLOCK CRIMPER		4
1	1	1	-	C	1-854830-4	CRIMPER, INSULATION		3
1	1	1	-	C	455888-7	SPACER, CRIMPER		2
1	1	1	-	C	3-456404-9	CRIMPER, WIRE		1
-3	-2	-1	U/M	DWG SIZE	PART NO	DESCRIPTION		ITEM NO

REVISION OF EACH ASSY NO (WHEN BLANK, USE DWG REVISION)

QTY REQD PER ASSY PARTS LIST

MATL HT TR FIN

DO NOT SCALE PRINT. TOLERANCES UNLESS OTHERWISE SPECIFIED.
 2 PLC DEC ±.02
 3 PLC DEC ±.01
 4 PLC DEC ±.005
 ANGLES ± -
 SURF TEXTURE: ✓
 REMOVE BURRS, BREAK SHARP EDGES R.015 MAX

DR P.Mathias 010CT98 APP T.ELBIN 010CT98
 CHK 010CT98 REL C.Erismann
 NAME SIDE FEED HDM APPLICATOR MACHINE REF MINI APPL
 SCALE DWG NO 680696 SHEET 1 OF 1 REV A

CAGE CODE 00779 CUSTOMER AND ASSEMBLY DRAWING RESTRICTED TO

THIS DRAWING IS A CONTROLLED DOCUMENT.

RELEASING FOR PUBLICATION
BY AMP INCORPORATED. ALL RIGHTS RESERVED.
AMP 1756 REV 3-92 11-JAN-99 13:08:09 amp05625 7