

THIS DRAWING IS UNPUBLISHED. RELEASED FOR PUBLICATION 20
 © COPYRIGHT 20 BY - ALL RIGHTS RESERVED.

REVISIONS				
P	LTR	DESCRIPTION	DATE	APVD
A		RELEASED ECO-14-003843	31MAR2014	LAW SB

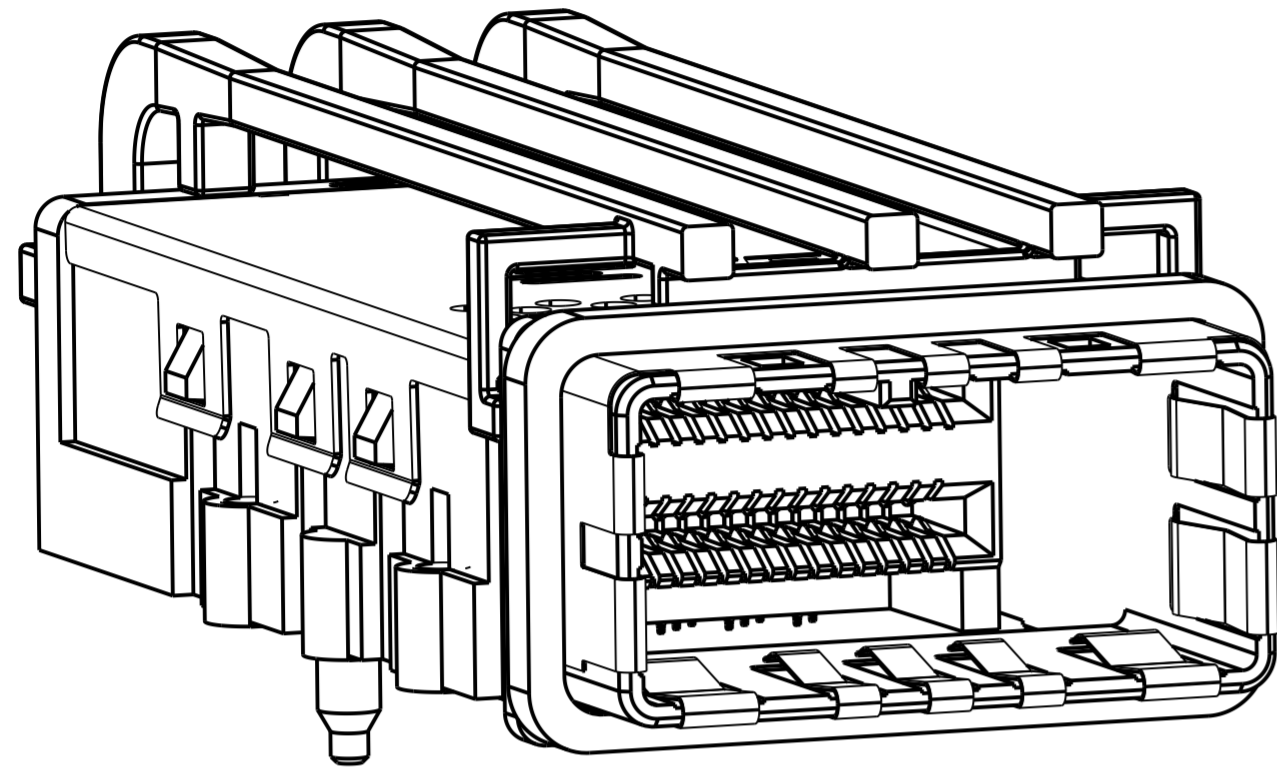

2149159-1
SCALE 4:1

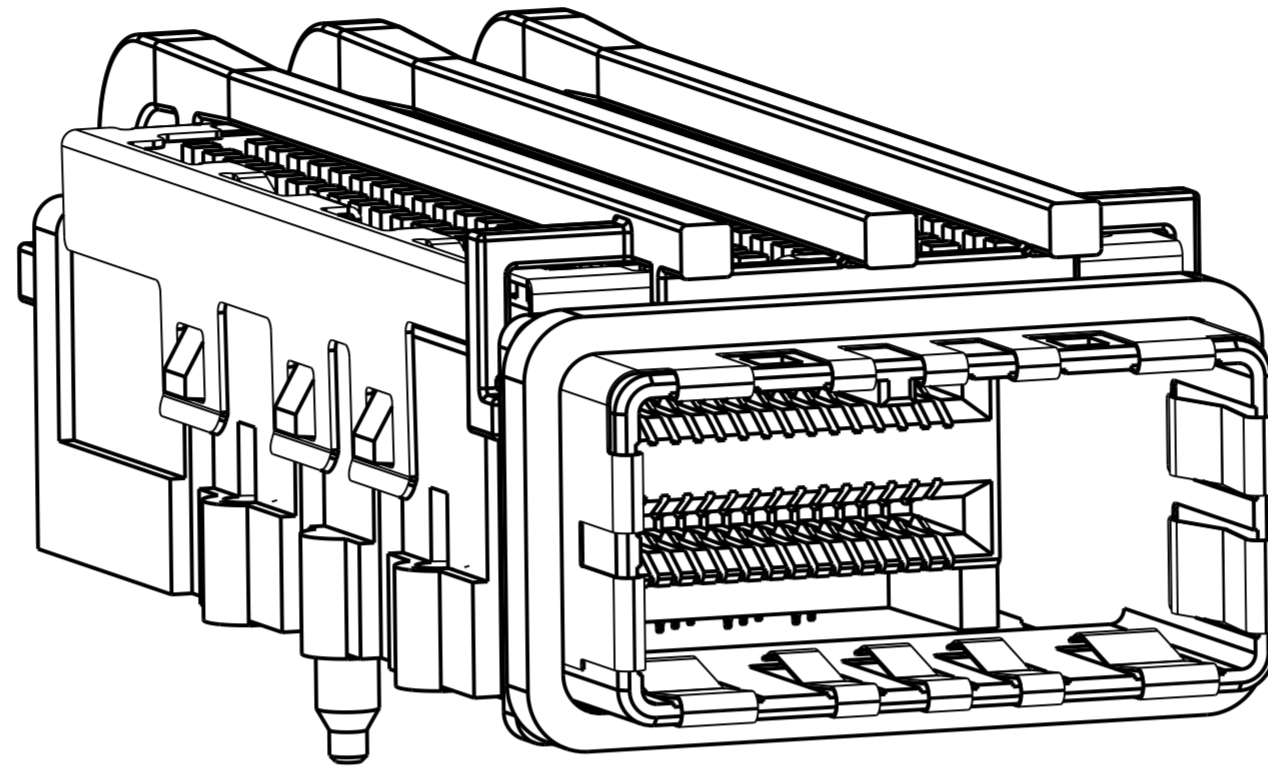

2149159-3
SCALE 4:1

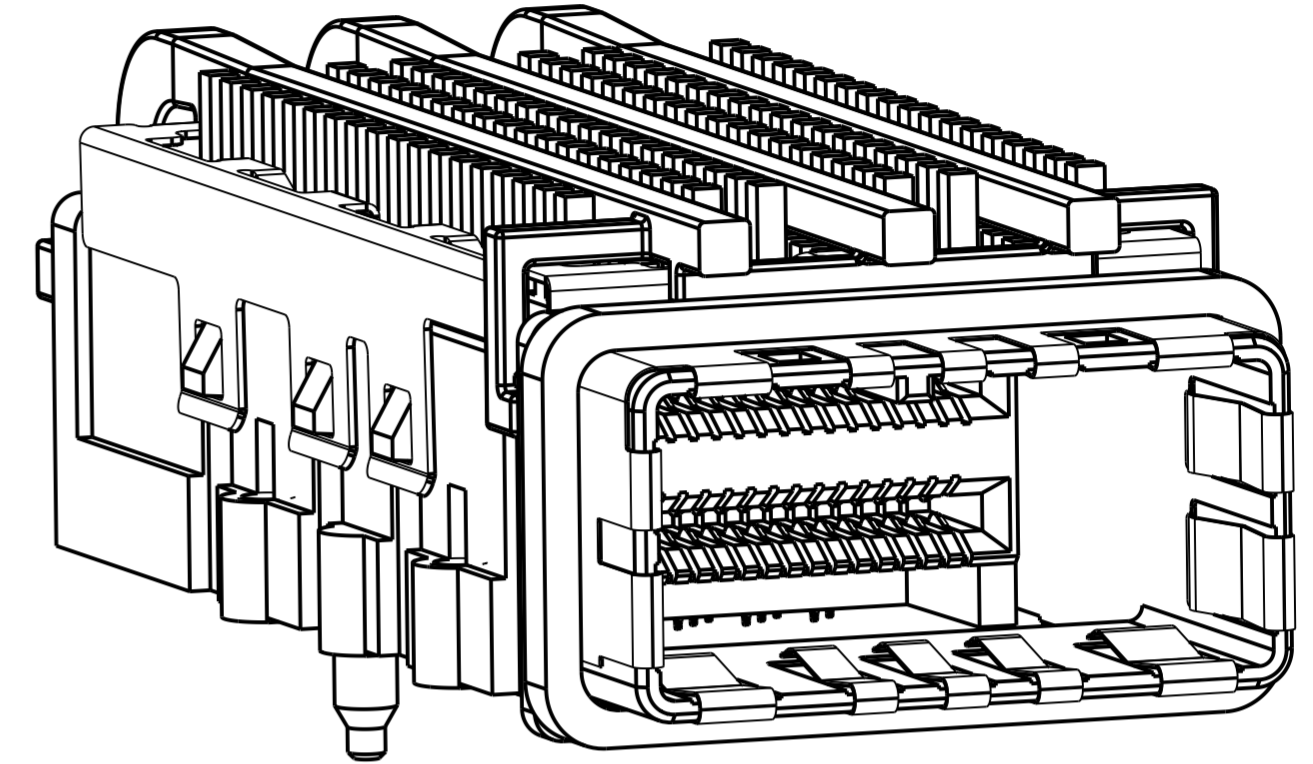

2149159-5
SCALE 4:1

OBSOLETE	23.5	2149448-2	△3	84 POSITION RECEPTACLE ASSEMBLY WITH LIGHTPIPE AND HEAT SINK	2149159-8
	23.5	2149448-1	△2	84 POSITION RECEPTACLE ASSEMBLY WITH LIGHTPIPE AND HEAT SINK	2149159-7
OBSOLETE	16.5	2149448-2	△3	84 POSITION RECEPTACLE ASSEMBLY WITH LIGHTPIPE AND HEAT SINK	2149159-6
	16.5	2149448-1	△2	84 POSITION RECEPTACLE ASSEMBLY WITH LIGHTPIPE AND HEAT SINK	2149159-5
OBSOLETE	14.2	2149448-2	△3	84 POSITION RECEPTACLE ASSEMBLY WITH LIGHTPIPE AND HEAT SINK	2149159-4
	14.2	2149448-1	△2	84 POSITION RECEPTACLE ASSEMBLY WITH LIGHTPIPE AND HEAT SINK	2149159-3
OBSOLETE	-	2149448-2	△3	884 POSITION RECEPTACLE ASSEMBLY WITH LIGHTPIPE	2149159-2
	-	2149448-1	△2	84 POSITION RECEPTACLE ASSEMBLY WITH LIGHTPIPE	2149159-1
E		RECEPTACLE HOUSING SUB-ASSEMBLY	FINISH	DESCRIPTION	PART NUMBER

THIS DRAWING IS A CONTROLLED DOCUMENT. DIMENSIONING AND TOLERANCING PER ASME Y14.5M-2009

DIMENSIONS: mm

TOLERANCES UNLESS OTHERWISE SPECIFIED:

0 PLC	±0.15
1 PLC	±0.15
2 PLC	±0.15
3 PLC	±
4 PLC	±
ANGLES	±
FINISH	±

DWN: M.E. COWHER 09 JUN 2010
 CHK: M.D. MORRISON 10 JUN 2010
 APVD: M.D. MORRISON 10 JUN 2010

PRODUCT SPEC: 108-2426
 APPLICATION SPEC: 114-13283

Customer Drawing

STE TE Connectivity

NAME: RECEPTACLE ASSEMBLY WITH LIGHTPIPE AND HEAT SINK, 84 POSITION, CXP

SIZE: A2 CAGE CODE: 00779 DRAWING NO: 2149159 RESTRICTED TO: -

SCALE: 1:1 SHEET: 1 OF 5 REV: A

THIS DRAWING IS UNPUBLISHED. RELEASED FOR PUBLICATION 20
 © COPYRIGHT 20 BY - ALL RIGHTS RESERVED.

REVISIONS				
P	LTR	DESCRIPTION	DATE	APVD
-		SEE SHEET 1	-	-

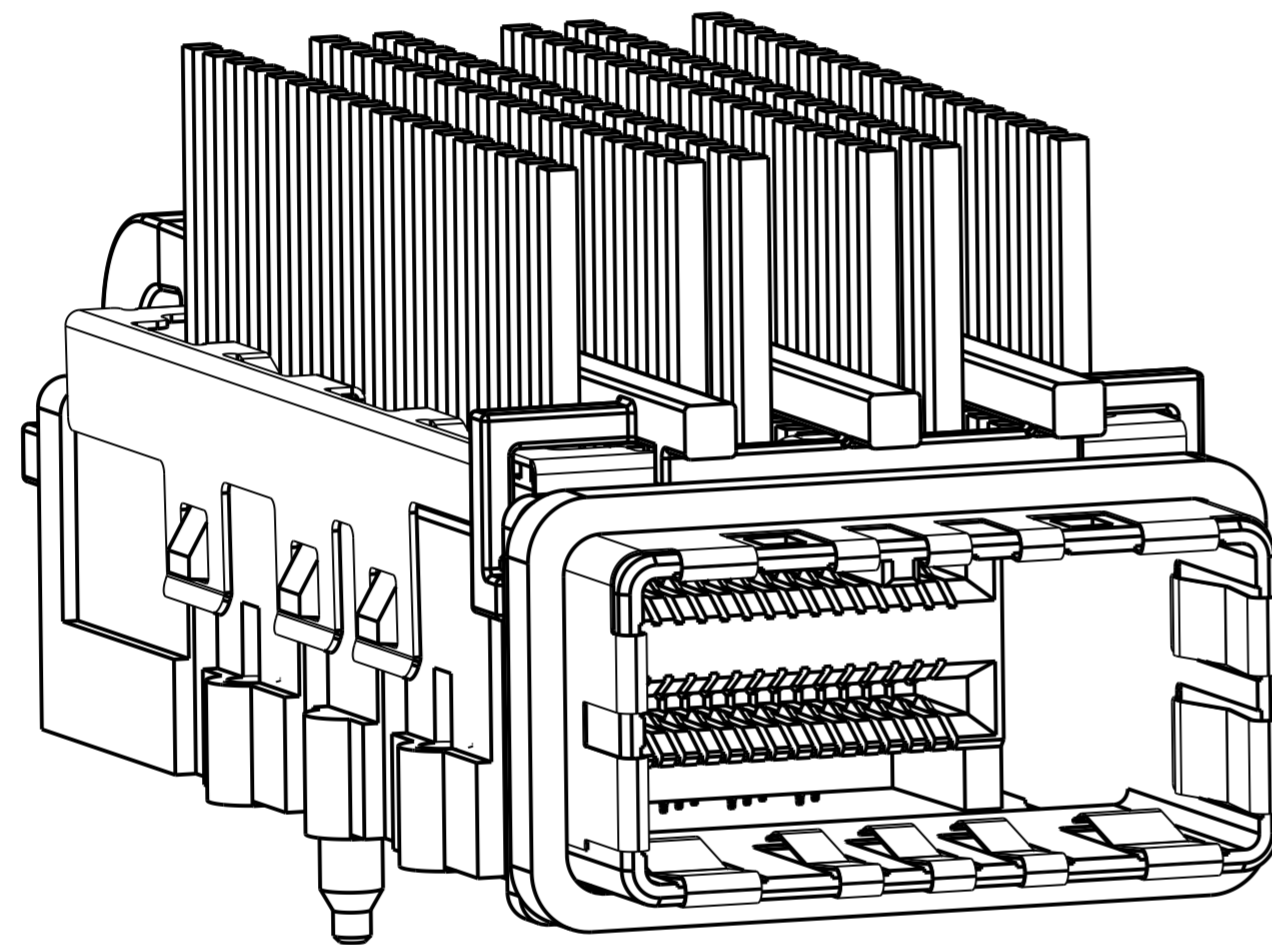

2149159-7
 SCALE 4:1

- 1 MATERIALS:
 HOUSING - ZINC ALLOY
 EMI GASKET - CONDUCTIVE URETHANE FOAM
 RECEPTACLE HOUSING - LCP, BLACK, UL 94V-0 RATED
 CHICKLET - LCP, BLACK, UL 94V-0 RATED
 CONTACT - PHOSPHOR BRONZE
 EMI SPRING - COPPER ALLOY
 HEAT SINK - ALUMINUM
 CLIP, HEAT SINK - STAINLESS STEEL
 LIGHTPIPE - POLYCARBONATE, CLEAR

- 2 FINISH:
 CONTACT - CONFORMS TO THE REQUIREMENTS OF TE
 PRODUCT SPECIFICATION 108-2426, BASED ON EIA/ECA-364-1000.01A,
 (CONTROLLED ENVIRONMENT APPLICATIONS) ON MATING INTERFACE,
 MATTE TIN PLATE OVER NICKEL UNDERPLATE ON COMPLIANT PIN
 HOUSING & HEAT SINK - NICKEL PLATE

3 NOTE DELETED

4 PCB THICKNESS = 1.57 MIN

5 FOR HOLE SIZE AND FINISHES, SEE APPLICATION SPEC 114-13283

6 THE ENTIRE AREA OF THE CONNECTOR FOOTPRINT, INDICATED
 BY CROSSHATCHING, TO BE CONSIDERED THE KEEPOUT AREA FOR
 COMPONENTS AND SIGNAL TRACES, TOP SIDE ONLY, TOP SIDE
 TRACES ALLOWED WITHIN CONNECTOR HOLE PATTERN, CROSSHATCHING
 TO BE CONDUCTIVE

7. MOUNTING HARDWARE REQUIRED:
 M2x0.4 (4)
 MOUNTING SCREW LENGTH = BOARD THICKNESS PLUS 4mm MAX

8. COMPONENTS PACKAGED UNASSEMBLED

THIS DRAWING IS A CONTROLLED DOCUMENT. DIMENSIONING AND TOLERANCING PER ASME Y14.5M-2009		DWN M. E. COWHER 09 JUN 2010	TE Connectivity	
DIMENSIONS: mm		CHK M. D. MORRISON 10 JUN 2010		
TOLERANCES UNLESS OTHERWISE SPECIFIED:		APVD M. D. MORRISON 10 JUN 2010	NAME RECEPTACLE ASSEMBLY WITH LIGHTPIPE AND HEAT SINK, 84 POSITION, CXP	
0 PLC ±0.15 1 PLC ±0.15 2 PLC ±0.15 3 PLC ± 4 PLC ± ANGLES ± FINISH ±		PRODUCT SPEC 108-2426	RESTRICTED TO	
MATERIAL		APPLICATION SPEC 114-13283	SIZE A2	CAGE CODE 00779
		WEIGHT -	DRAWING NO C-2149159	SCALE 1:1
		Customer Drawing	SHEET 2	OF 5
			REV A	

THIS DRAWING IS UNPUBLISHED. RELEASED FOR PUBLICATION 20
 © COPYRIGHT 20 BY - ALL RIGHTS RESERVED.

REVISIONS				
P	LTR	DESCRIPTION	DATE	APVD
-		SEE SHEET 1	-	-

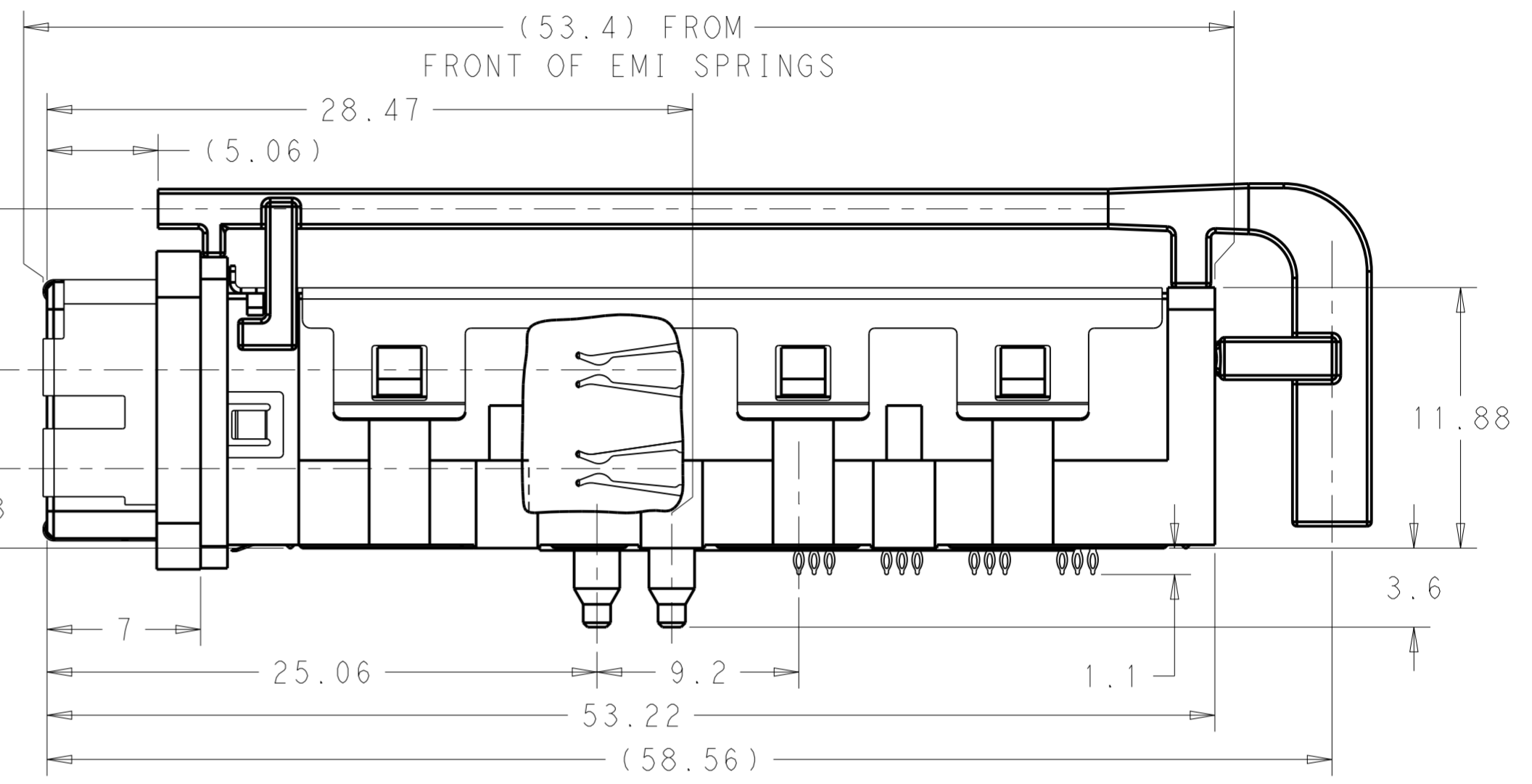
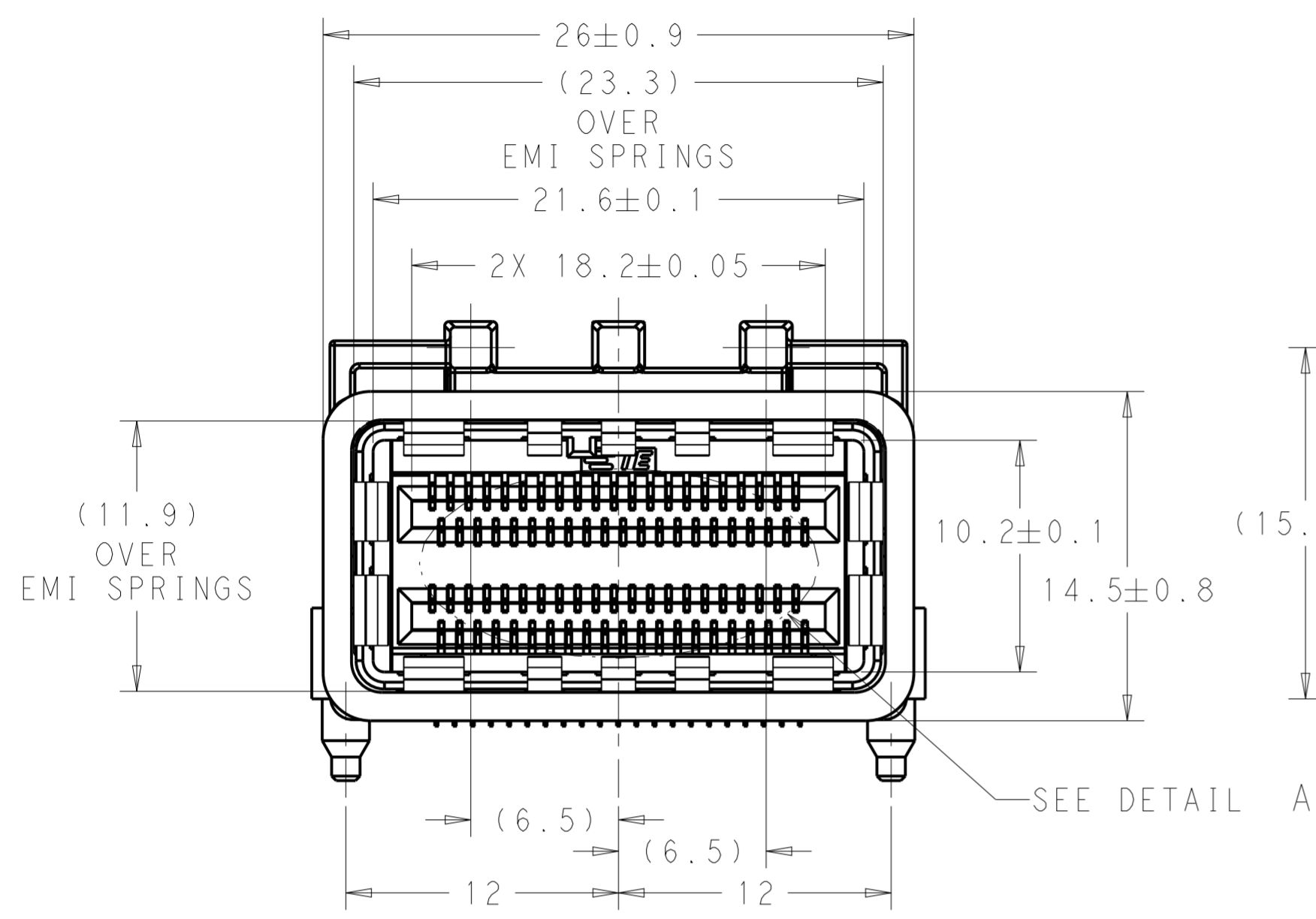

2149159-1
 SCALE 4:1

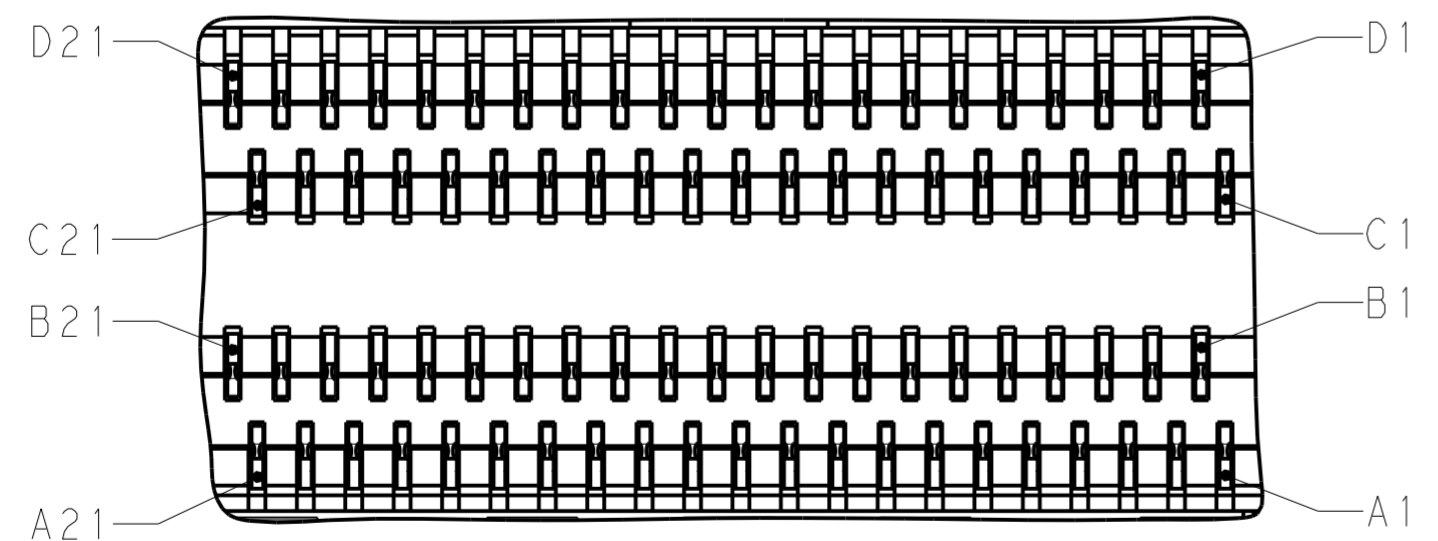

DETAIL A
 RECOMMENDED PIN CALLOUT
 SCALE 8:1

THIS DRAWING IS A CONTROLLED DOCUMENT. DIMENSIONING AND TOLERANCING PER ASME Y14.5M-2009		DWN 09 JUN 2010 M. E. COWHER	 TE Connectivity	NAME		
DIMENSIONS: mm		CHK 10 JUN 2010 M. D. MORRISON		RECEPTACLE ASSEMBLY WITH LIGHTPIPE AND HEAT SINK, 84 POSITION, CXP		
TOLERANCES UNLESS OTHERWISE SPECIFIED:		APVD 10 JUN 2010 M. D. MORRISON		SIZE	CAGE CODE	DRAWING NO
0 PLC ±0.15 1 PLC ±0.15 2 PLC ±0.15 3 PLC ± 4 PLC ± ANGLES ± FINISH ±		PRODUCT SPEC 108-2426		A200779	C-2149159	RESTRICTED TO
MATERIAL		APPLICATION SPEC 114-13283	WEIGHT	SCALE 1:1	SHEET 3 OF 5	
		Customer Drawing			REV A	

THIS DRAWING IS UNPUBLISHED. RELEASED FOR PUBLICATION 20
 © COPYRIGHT 20 BY - ALL RIGHTS RESERVED.

REVISIONS				
P	LTR	DESCRIPTION	DATE	APVD
-	-	SEE SHEET 1	-	-

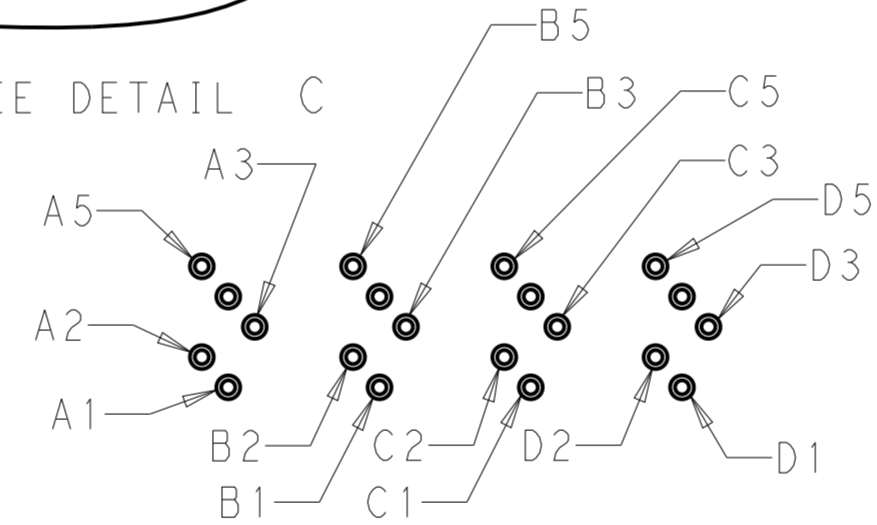
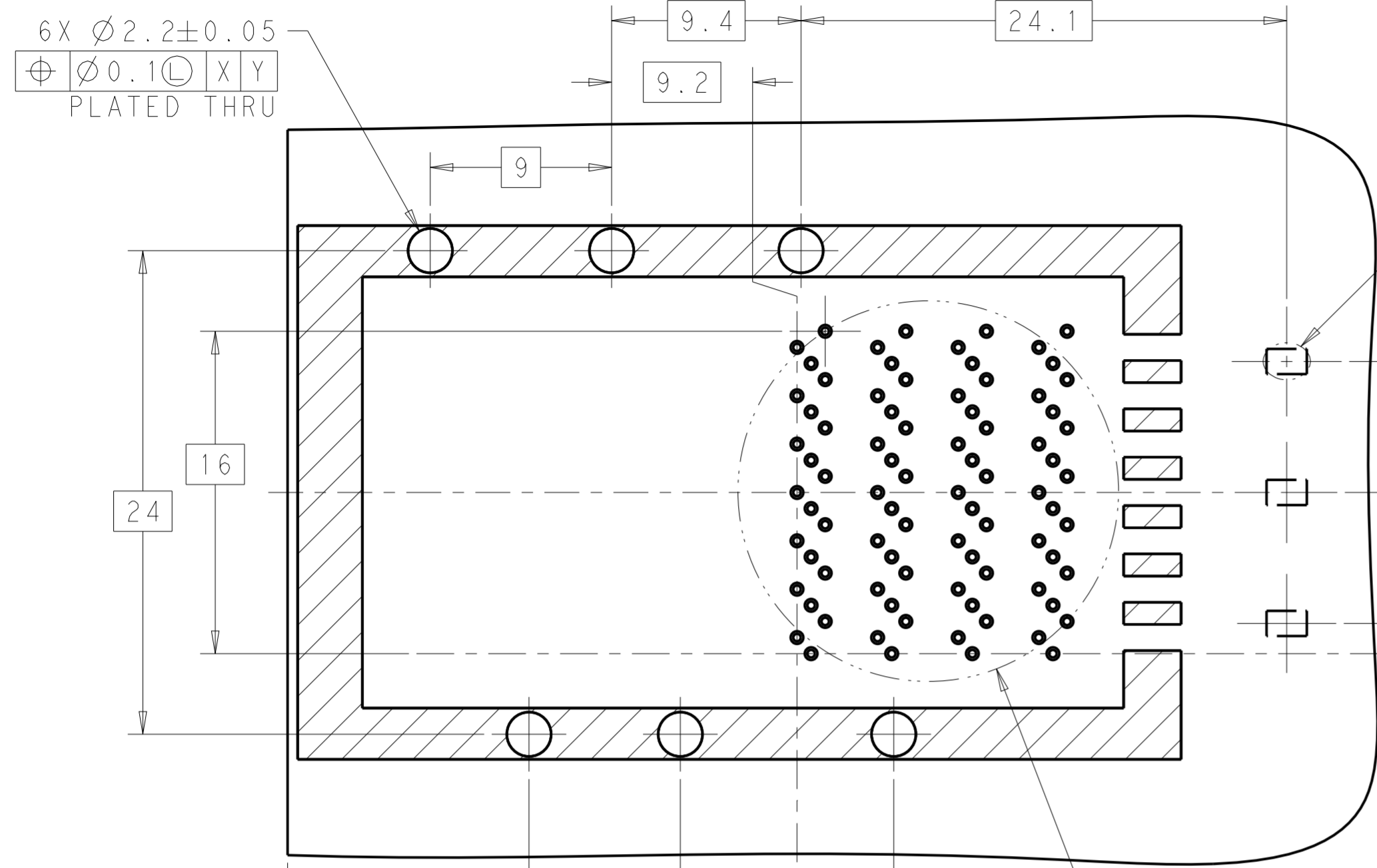

84X $\text{Ø}0.37 \pm 0.05$
 $\text{Ø}0.1 \text{ L X Y}$

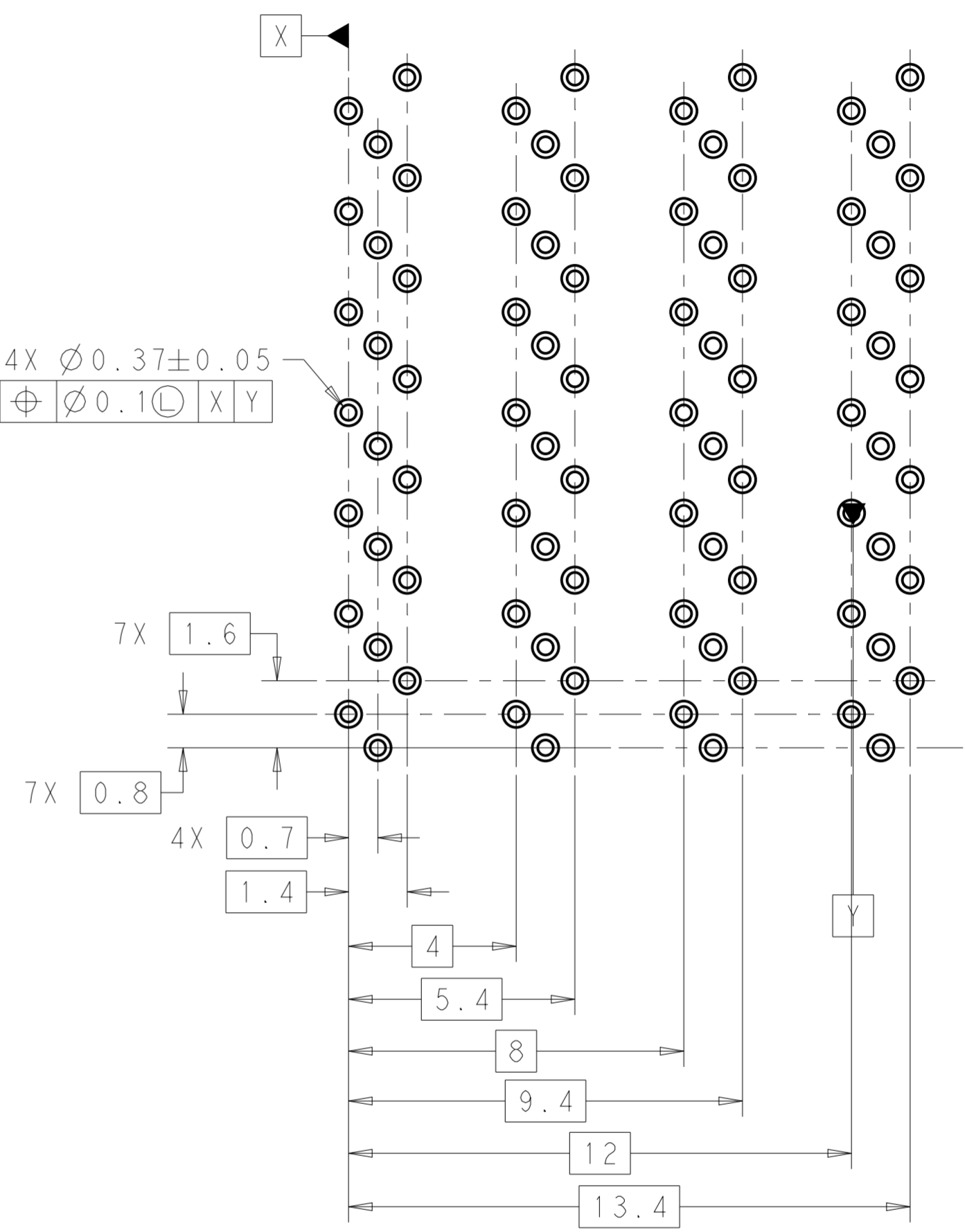

RECOMMENDED PCB LAYOUT
 COMPONENT SIDE SHOWN
 SCALE 4:1

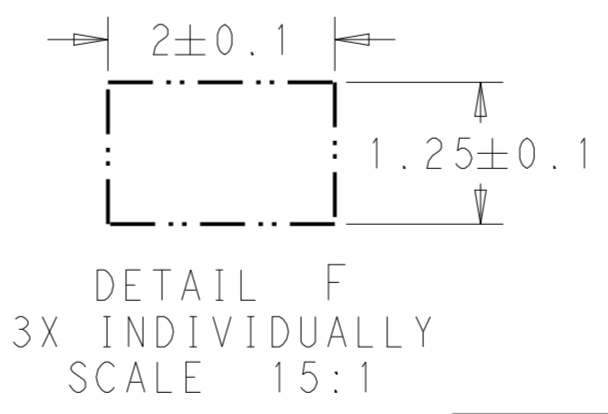
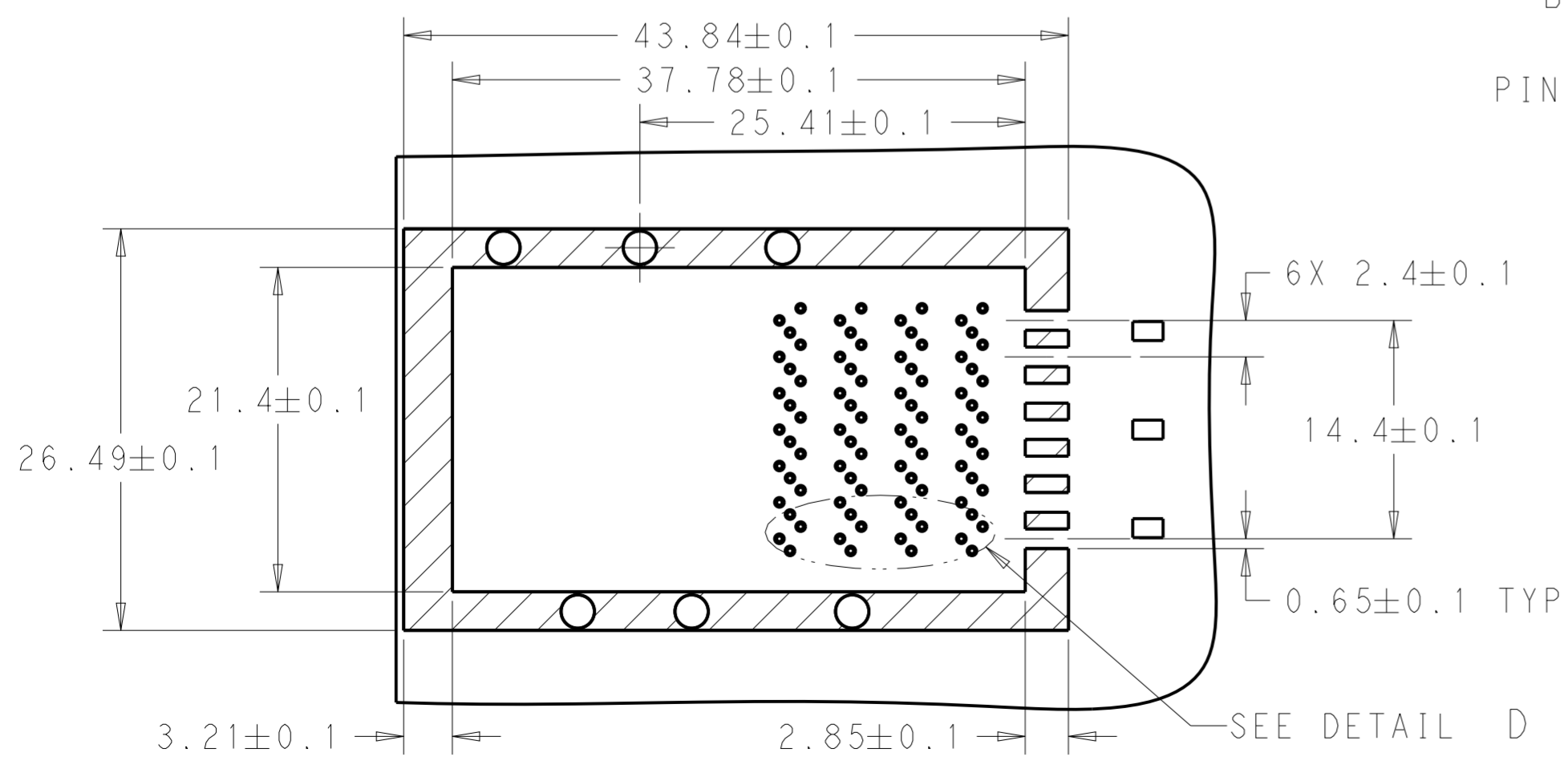

THIS DRAWING IS A CONTROLLED DOCUMENT. DIMENSIONING AND TOLERANCING PER ASME Y14.5M-2009		DWN 09 JUN 2010 M. E. COWHER	TE Connectivity
DIMENSIONS: mm		CHK 10 JUN 2010 M. D. MORRISON	
TOLERANCES UNLESS OTHERWISE SPECIFIED:		APVD 10 JUN 2010 M. D. MORRISON	NAME
0 PLC ±0.15		PRODUCT SPEC	RECEPTACLE ASSEMBLY WITH LIGHTPIPE AND HEAT SINK, 84 POSITION, CXP
1 PLC ±0.15		APPLICATION SPEC	SIZE CAGE CODE DRAWING NO
2 PLC ±0.15		114-13283	A200779 C-2149159
3 PLC ±		WEIGHT	RESTRICTED TO
4 PLC ±		Customer Drawing	SCALE 1:1 SHEET 4 OF 5 REV A
ANGLES ±			
FINISH ±			

THIS DRAWING IS UNPUBLISHED. RELEASED FOR PUBLICATION 20
 © COPYRIGHT 20 BY - ALL RIGHTS RESERVED.

REVISIONS				
P	LTR	DESCRIPTION	DATE	APVD
-	-	SEE SHEET 1	-	-

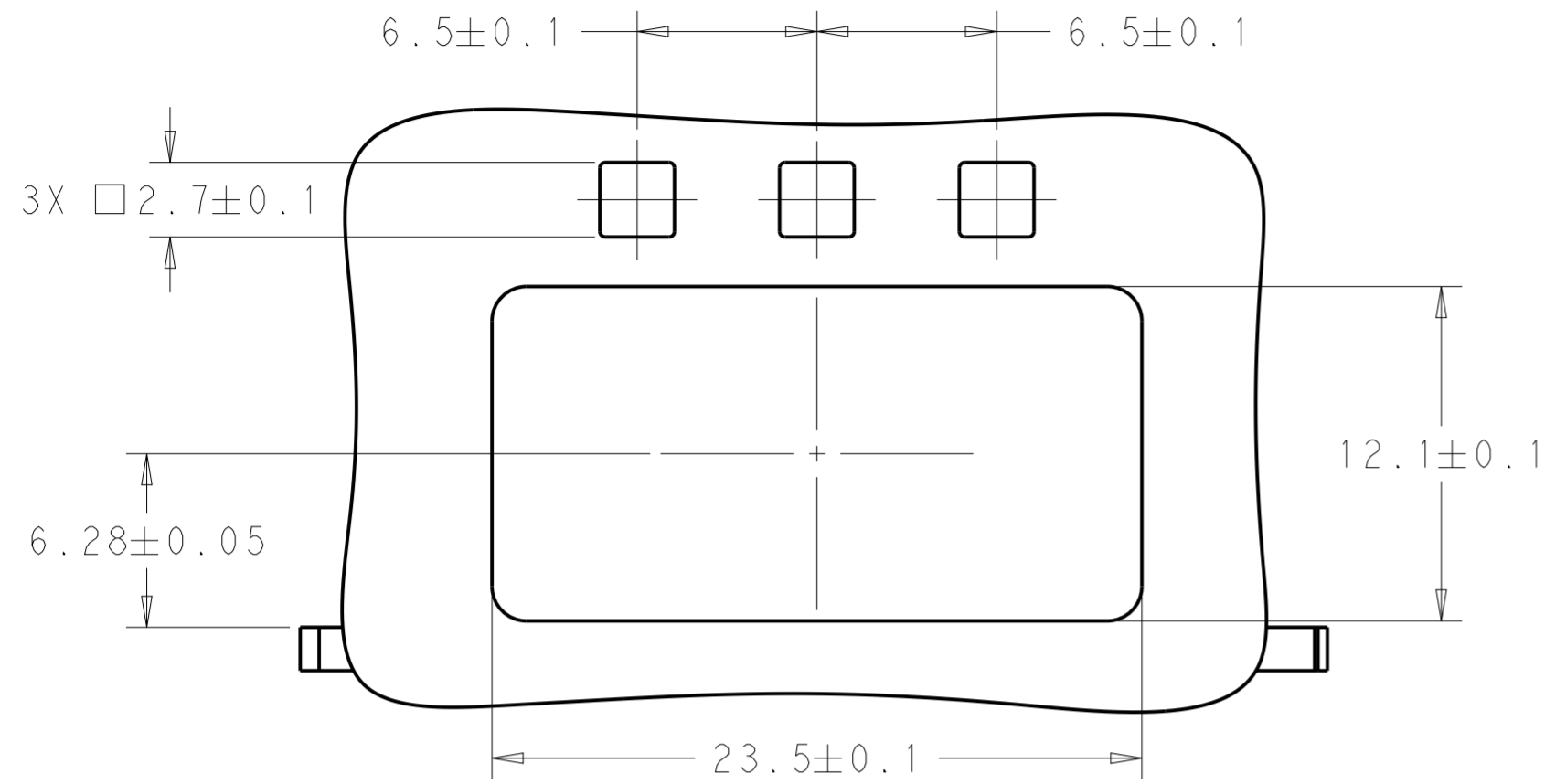

RECOMMENDED BRACKET CUT-OUT
SCALE 4:1

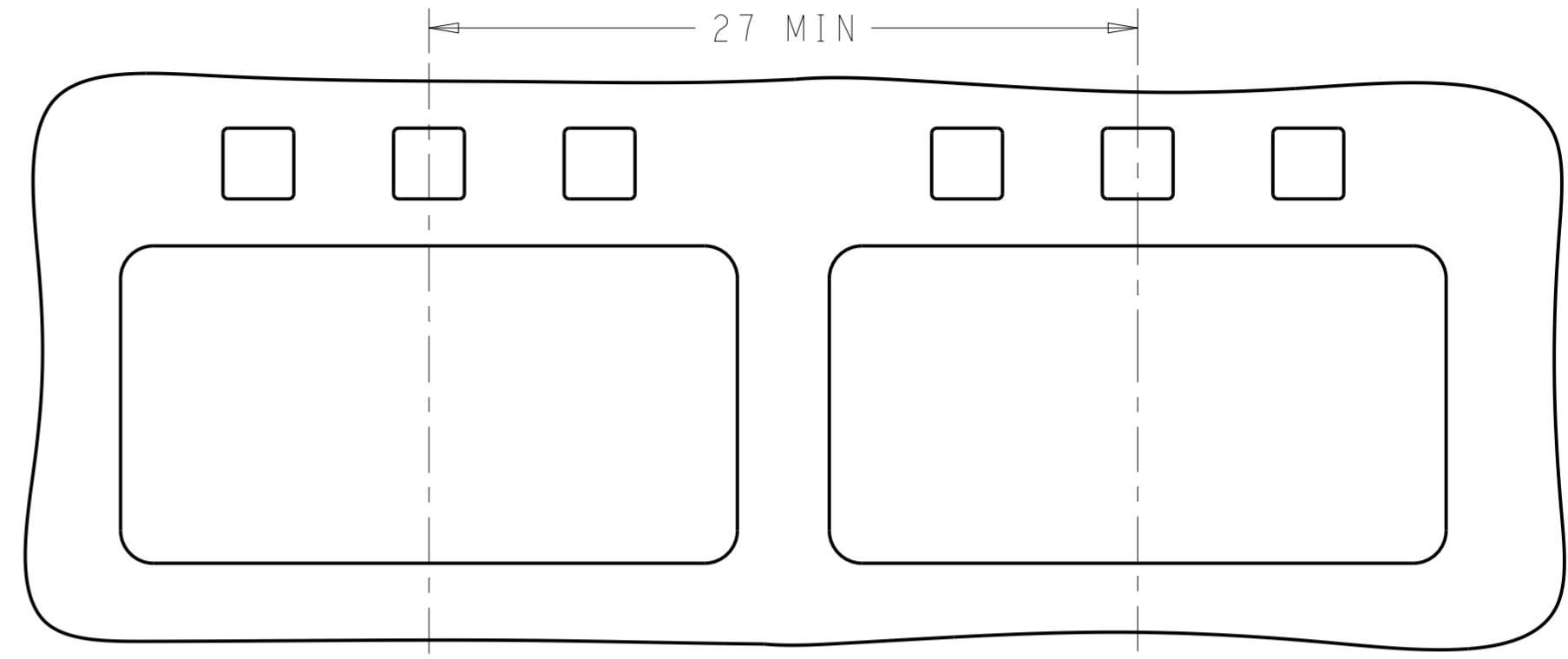

RECOMMENDED BRACKET CUT-OUT SPACING
SCALE 4:1

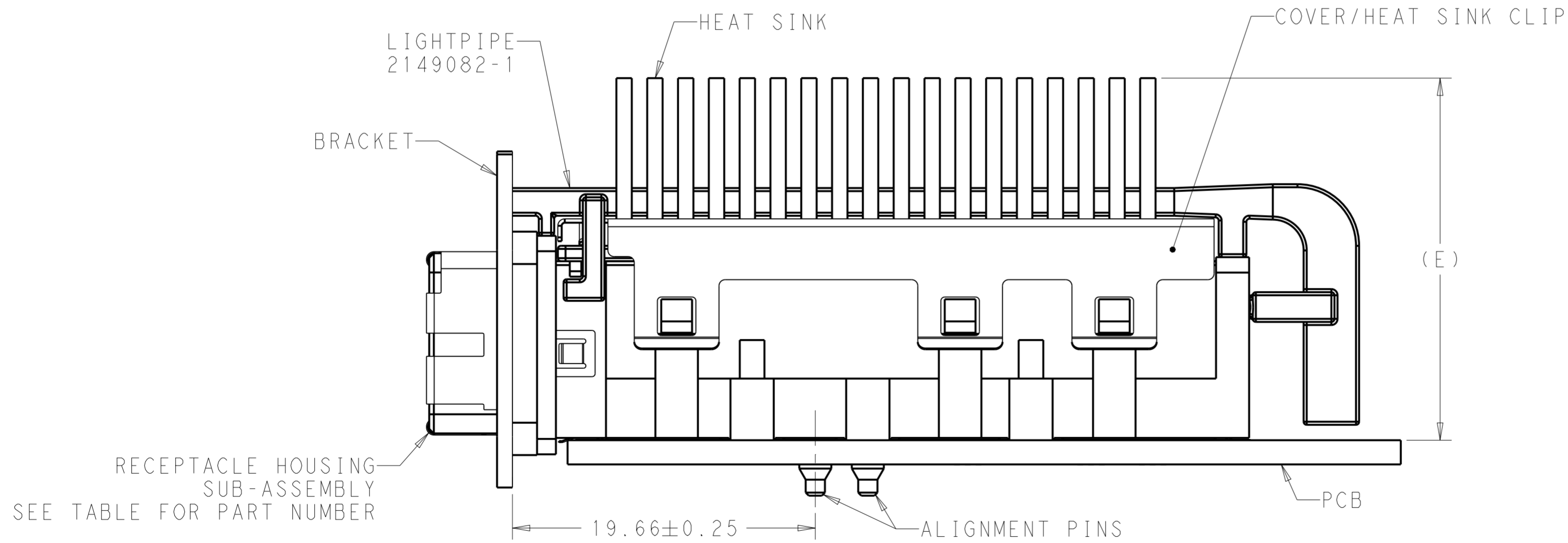

RECOMMENDED BRACKET LOCATION AND
HEIGHT OF HEAT SINK MEASURED FROM PCB
SCALE 4:1

THIS DRAWING IS A CONTROLLED DOCUMENT. DIMENSIONING AND TOLERANCING PER ASME Y14.5M-2009

DIMENSIONS:	TOLERANCES UNLESS OTHERWISE SPECIFIED:
mm	0 PLC ±0.15
	1 PLC ±0.15
	2 PLC ±0.15
	3 PLC ±
	4 PLC ±
	ANGLES ±
	FINISH ±

DWN	09 JUN 2010
CHK	10 JUN 2010
APVD	10 JUN 2010
PRODUCT SPEC	108-2426
APPLICATION SPEC	114-13283
WEIGHT	-
Customer Drawing	

TE Connectivity		NAME	
		RECEPTACLE ASSEMBLY WITH LIGHTPIPE AND HEAT SINK, 84 POSITION, CXP	
SIZE	CAGE CODE	DRAWING NO	RESTRICTED TO
A2	00779	C-2149159	-
SCALE	1:1	SHEET	5 OF 5
REV	A		