

Development Board EPC9080 Quick Start Guide

EPC2045 and EPC2022

100 V Half-bridge with Gate Drive, Using EPC2045 & EPC2022



DESCRIPTION

The EPC9080 development board is a 100 V maximum device voltage, 30 A maximum output current, half bridge with onboard gate drives, featuring the EPC2045 and EPC2022 enhancement mode (eGaN®) field effect transistors (FETs) designed for high step down, high current applications. The purpose of this development board is to simplify the evaluation process of the EPC2045 and EPC2022 eGaN FETs by including all the critical components on a single board that can be easily connected into any existing converter.

The EPC9080 development board is 2" x 2" and contains one high side EPC2045 eGaN FET and one low side EPC2022 eGaN FET in a half bridge configuration using the Texas Instruments LM5113 gate driver. The board also contains all critical components and layout for optimal switching performance. There are also various probe points to facilitate simple waveform measurement and efficiency calculation. A block diagram of the circuit is given in figure 1.

For more information on the EPC2045 and EPC2022 please refer to the datasheet available from EPC at www.epc-co.com. The datasheet should be read in conjunction with this quick start guide.

QUICK START PROCEDURE

Development board EPC9080 is easy to set up to evaluate the performance of EPC2045 and EPC2022 eGaN FETs. Refer to figure 2 for proper connect and measurement setup and follow the procedure below:

1. With power off, connect the input power supply bus to +VIN (J5, J6) and ground / return to -VIN (J7, J8).
2. With power off, connect the switch node (SW) of the half bridge OUT (J3, J4) to your circuit as required (half bridge configuration). The EPC9080 features an optional buck converter configuration, as shown in figure 2, with unpopulated footprints for an output inductor and output capacitors.
3. With power off, connect the gate drive input to +VDD (J1, Pin-1) and ground return to -VDD (J1, Pin-2).
4. With power off, connect the input PWM control signal to PWM (J2, Pin-1) and ground return to any of the remaining J2 pins.
5. Turn on the gate drive supply – make sure the supply is between 7.5 V and 12 V range.
6. Turn on the controller / PWM input source.
7. Turn on the bus voltage to the required value (do not exceed the absolute maximum voltage) and probe switching node to see switching operation.
8. Once operational, adjust the PWM control, bus voltage, and load within the operating range and observe the output switching behavior, efficiency and other parameters.
9. For shutdown, please follow steps in reverse.

Table 1: Performance Summary (T_A = 25°C) EPC9080

Symbol	Parameter	Conditions	Min	Max	Units
V _{DD}	Gate Drive Input Supply Range		7.5	12	V
V _{IN}	Bus Input Voltage Range ⁽¹⁾			80	V
I _{OUT}	Switch Node Output Current ⁽²⁾			30	A
V _{PWM}	PWM Logic Input Voltage Threshold	Input 'High' Input 'Low'	3.5 0	6 1.5	V V
	Minimum 'High' State Input Pulse Width	V _{PWM} rise and fall time < 10ns	50		ns
	Minimum 'Low' State Input Pulse Width ⁽³⁾	V _{PWM} rise and fall time < 10ns	200		ns

(1) Maximum input voltage depends on inductive loading, maximum switch node ringing must be kept under 100 V for EPC2045 and EPC2022.

(2) Maximum current depends on die temperature – actual maximum current will be subject to switching frequency, bus voltage and thermal cooling.

(3) Limited by time needed to 'refresh' high side bootstrap supply voltage.

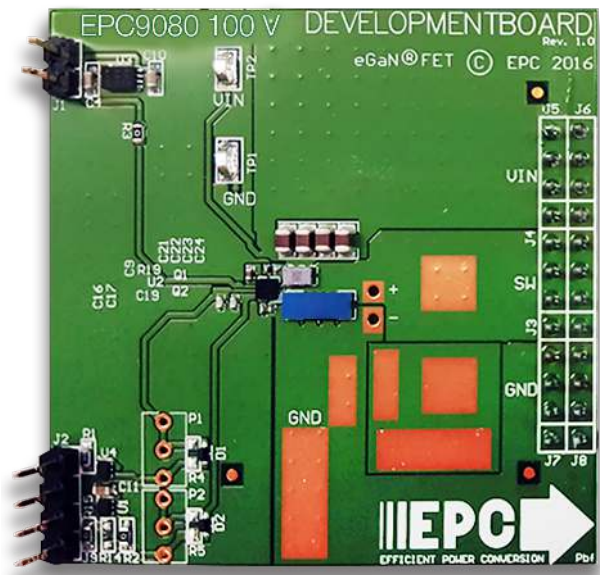

EPC9080 development board

NOTE. When measuring the high frequency content switch node, care must be taken to provide an accurate high speed measurement. An optional two pin header (J10) is included for switch node measurement. It is recommended to install measurement point on backside of board to prevent contamination of the top side components.

For information about measurement techniques, please review the how to GaN series: HTG09- Measurement

<http://epc-co.com/epc/DesignSupport/TrainingVideos/HowtoGaN/>

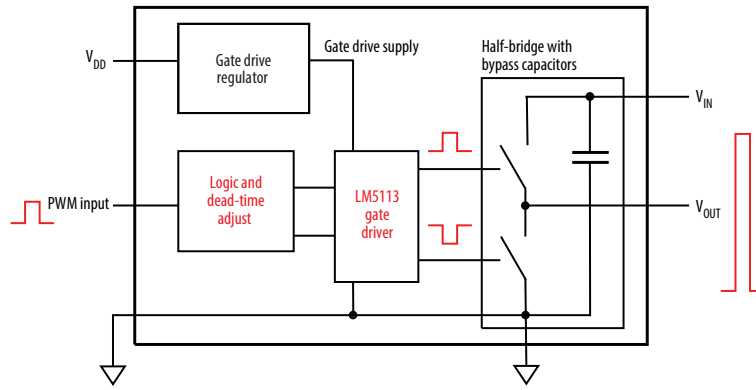

Figure 1: Block diagram of EPC9080 development board.

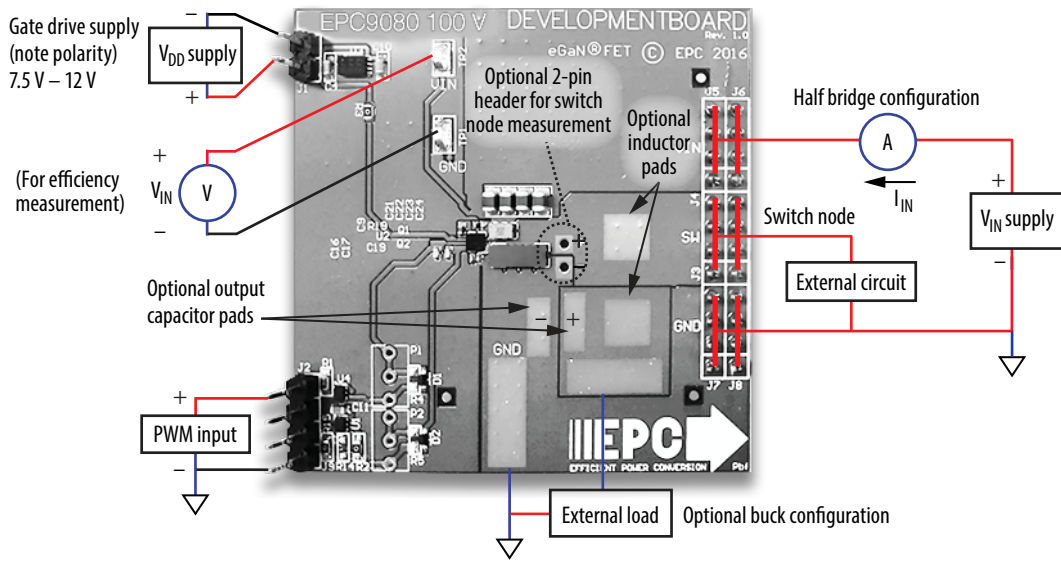
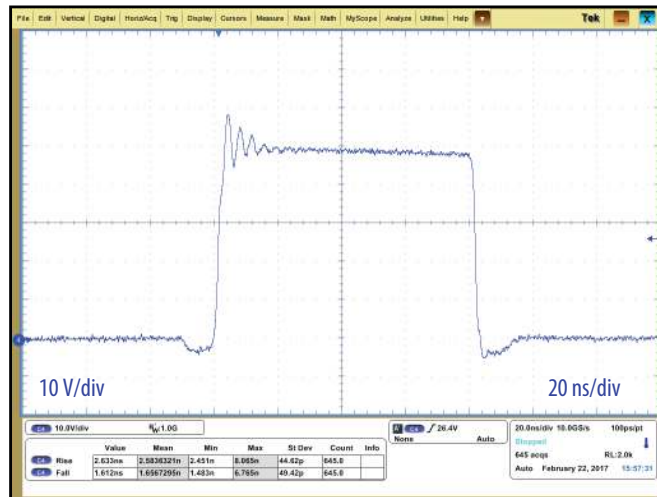

Figure 2: Proper connection and measurement setup.



$$V_{IN} = 48 \text{ V}, V_{OUT} = 1.8 \text{ V}, I_{OUT} = 20 \text{ A}, f_{SW} = 500 \text{ kHz}$$

Figure 3: Typical Waveform for $V_{IN} = 48 \text{ V}$ to 1.8 V_{OUT} , 20 A (500 kHz) Buck Converter.

THERMAL CONSIDERATIONS

The EPC9080 development board showcases the EPC2045 and EPC2022 eGaN FET. The EPC9080 is intended for bench evaluation with low ambient temperature and convection cooling. The addition of heat-sinking and forced air cooling can significantly increase the current rating of these devices, but care must be taken to not exceed the absolute maximum die temperature of 150° C.

NOTE. The EPC9080 development board does not have any current or thermal protection on board.

For more information regarding the thermal performance of EPC eGaN FETs, please consult:

D. Reusch and J. Glaser, *DC-DC Converter Handbook*, a supplement to *GaN Transistors for Efficient Power Conversion*, First Edition, Power Conversion Publications, 2015.

Table 2: Bill of Materials

Item	Qty	Reference	Part Description	Manufacturer/Part Number
1	3	C4, C10, C11	Capacitor, 1 μ F, 10%, 25 V, X5R	Murata, GRM188R61E105KA12D
2	1	C9	Capacitor, 0.1 μ F, 10%, 25 V, X5R	TDK, C1005X5R1E104K050BC
3	2	C16, C17	Capacitor, 100 pF, 5%, 50 V, NP0	Kemet, C0402C101K5GACTU
4	1	C19	Capacitor, 1 μ F, 10%, 25 V, X5R	TDK, C1005X5R1E105K050BC
5	4	C21, C22, C23, C24	Capacitor, CER 1 μ F 100 V 20% X7S 0805	TDK, C2012X7S2A105M125AB
6	2	D1, D2	Schottky Diode, 30 V	Diodes Inc., SDM03U40-7
7	1	Q1	eGaN FET, 100 V, 7 m Ω	EPC, EPC2045
8	1	Q2	eGaN FET, 100 V, 3.2 m Ω	EPC, EPC2022
9	1	U1	IC GATE NAND 1CH 2-INP 6MICROPAK	Fairchild, NC7SZ00L6X
10	1	U2	Gate Driver, LM5113, USMD, BGA	Texas Instruments, LM5113
11	1	U3	I.C., Regulator MCP1703T-5002E/MC	Microchip, MCP1703T-5002E/MC
12	1	U4	IC GATE AND 1CH 2-INP 6-MICROPAK	Fairchild, NC7SZ08L6X
13	1	R1	Resistor, 10.0 K, 5%, 1/8W	Stackpole, RMCFO603FT10K0
14	3	R2, R15, R3	Resistor, 0 Ω , 1/8W, 0603	ERJ-3GEY0R00V
15	1	R4	RES SMD 115 Ω 1% 1/10W 0603	311-115HRTR-ND
16	1	R5	RES SMD 120 Ω 1% 1/10W 0603	311-120HRTR-ND
17	1	R19	RES SMD 0.0 Ω JUMPER 1/16W	Stackpole, RMCFO402ZT0R00TR-ND
18	3	J1, J2, J9	Connector, 2pins of Tyco, 4-103185-0	2 pins of Tyco, 4-103185-0
19	6	J3, J4, J5, J6, J7, J8	Connector, FCI, 68602-224HLF	FCI, 68602-224HLF
20	2	TP1, TP2	Test Point, Keystone Elect, 5015	Keystone Elect, 5015

Optional Components

Item	Qty	Reference	Part Description	Manufacturer/Part Number
1	DNP	P1,P2	Optional Potentiometer	
2	DNP	FD1, FD2, FD3	PCB Fiducial	
3	DNP	J10	VSW probe	
4	DNP	R14	Low side drive PWM option	

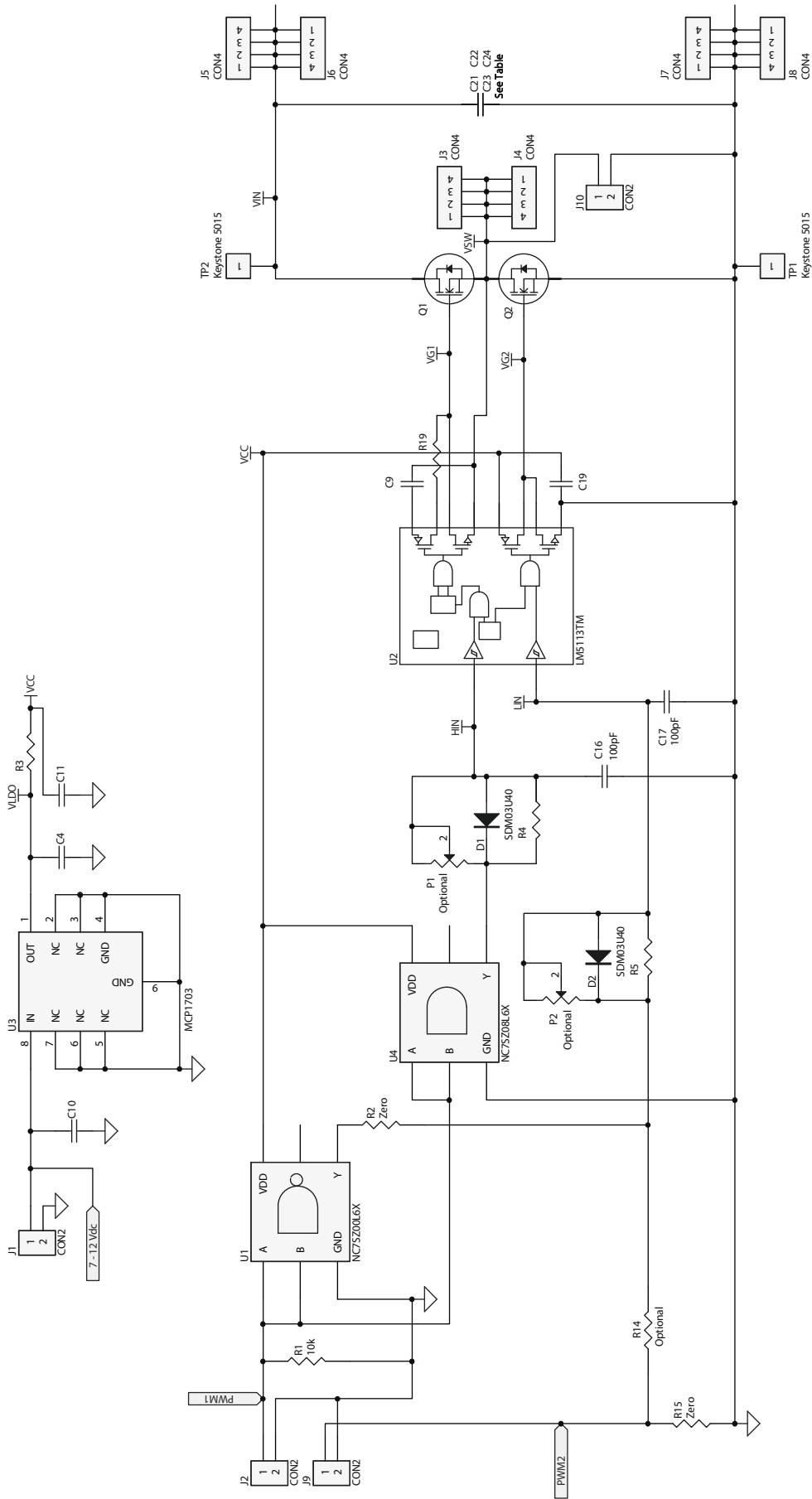

Figure 4: EPC9080 - Schematic

For More Information:

Please contact info@epc-co.com
or your local sales representative

Visit our website:
www.epc-co.com

Sign-up to receive
EPC updates at
bit.ly/EPCupdates
or text "EPC" to 22828



EPC Products are distributed through Digi-Key.
www.digikey.com

Demonstration Board Notification

The EPC9080 board is intended for product evaluation purposes only and is not intended for commercial use. Replace components on the Evaluation Board only with those parts shown on the parts list (or Bill of Materials) in the Quick Start Guide. Contact an authorized EPC representative with any questions.

This board is intended to be used by certified professionals, in a lab environment, following proper safety procedures. Use at your own risk.

As an evaluation tool, this board is not designed for compliance with the European Union directive on electromagnetic compatibility or any other such directives or regulations. As board builds are at times subject to product availability, it is possible that boards may contain components or assembly materials that are not RoHS compliant. Efficient Power Conversion Corporation (EPC) makes no guarantee that the purchased board is 100% RoHS compliant.

The Evaluation board (or kit) is for demonstration purposes only and neither the Board nor this Quick Start Guide constitute a sales contract or create any kind of warranty, whether express or implied, as to the applications or products involved.

Disclaimer: EPC reserves the right at any time, without notice, to make changes to any products described herein to improve reliability, function, or design. EPC does not assume any liability arising out of the application or use of any product or circuit described herein; neither does it convey any license under its patent rights, or other intellectual property whatsoever, nor the rights of others.