

THIS DRAWING IS UNPUBLISHED. RELEASED FOR PUBLICATION - N/A .
 © COPYRIGHT N/A By - ALL RIGHTS RESERVED.

LOC	DIST	REVISIONS					
DF	A5	P	LTR	DESCRIPTION	DATE	DWN	APVD
		Y		REV PER ECO-11-011391	13JUL11	PY	DM

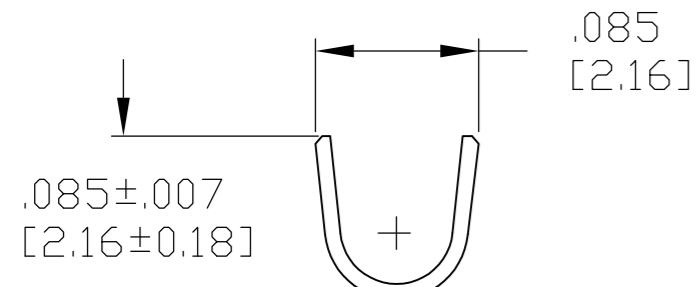

SECTION B-B
INSULATION BARREL

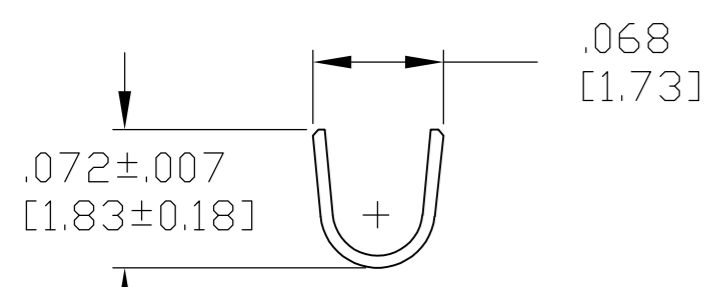

SECTION A-A
WIRE BARREL

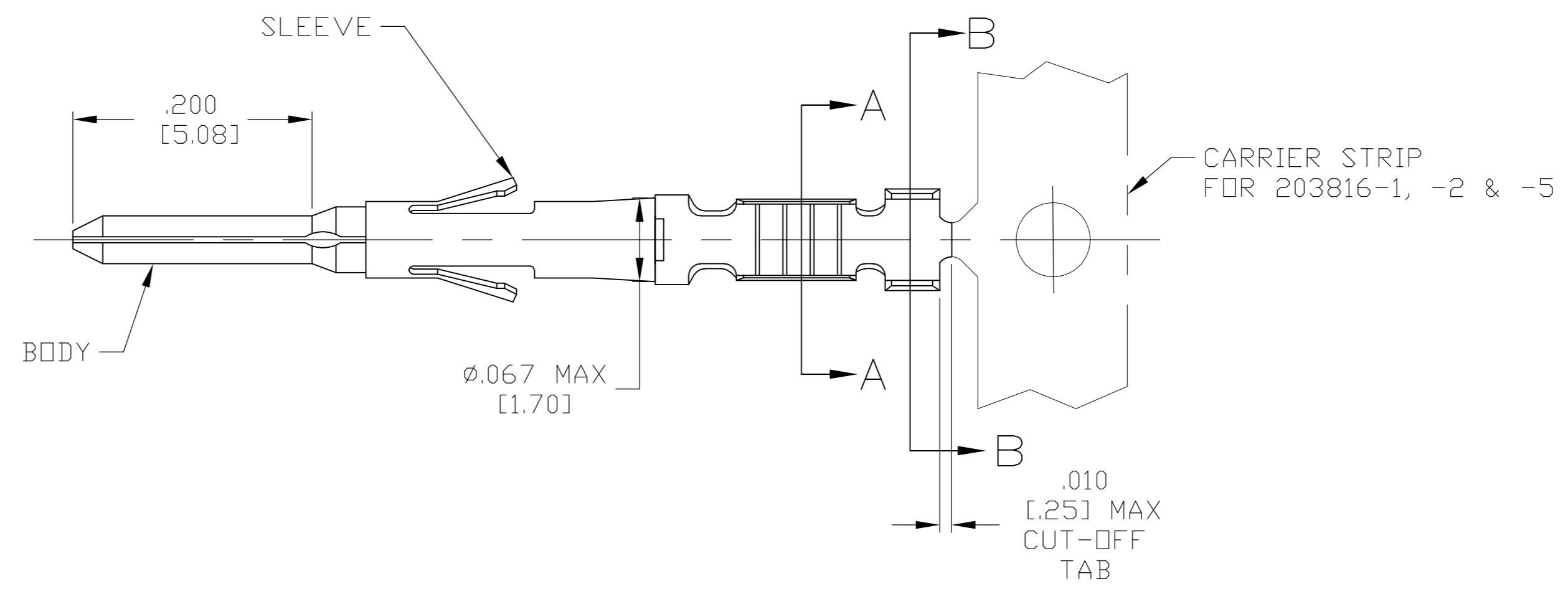

INDICATES WIRE RANGE OF 20, 22 AND 24

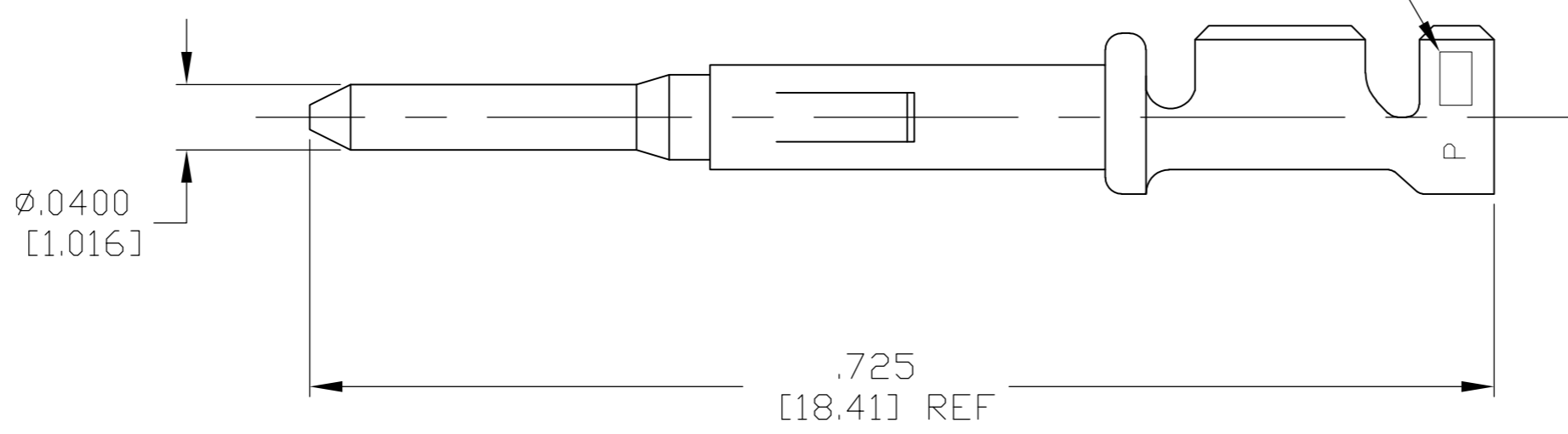

- 1 MATERIAL: BODY: BRASS PER ASTM-B-19
SLEEVE: STAINLESS STEEL PER ASTM-A-240.
- 2 FINISH: .000030 MIN THK GOLD PER ASTM-B-488
OVER .000050 MIN THK NICKEL PER AMS-QQ-N-290.
- 3 FINISH: SELECTIVE .000030 MIN THK GOLD PER ASTM-B-488
OVER .000050 MIN THK NICKEL PER AMS-QQ-N-290.
- 4 FINISH: .000150 MIN TIN OVER NICKEL FLASH.
CAUTION: USE OF TIN PLATED TERMINALS IN CERTAIN ENVIRONMENT MAY CAUSE NON-COMFORMANCE TO TYCO PRODUCT SPECIFICATION 108-10015.
- 5. WIRE RANGE: 20, 22 & 24 AWG
INSULATION RANGE: .062 MAX.
HAND CRIMPING TOOL: TYCO P/N 90260-1
EXTRACTION TOOL: TYCO P/N 91038-3
INSERTION TOOL: TYCO P/N 91042-1
- 6. PART NUMBERS 203816-7 THRU 1-203816-6 ARE OBSOLETE.

	LOOSE PIECE	4	1	203816-6
	ON STRIP	4	1	203816-5
	LOOSE PIECE	3	1	203816-4
OBsolete	LOOSE PIECE	2	1	203816-3
	ON STRIP	3	1	203816-2
OBsolete	ON STRIP	2	1	203816-1
	REMARKS	FINISH	MATERIAL	PART NO.

THIS DRAWING IS A CONTROLLED DOCUMENT.

DIMENSIONS: INCHES	TOLERANCES UNLESS OTHERWISE SPECIFIED:	DWN: C.C.THOMAS 3-29-05	
	0 PLC ± -	CHK: D.MILLER 3-29-05	
	1 PLC ± -	APVD: D.MILLER 3-29-05	
	2 PLC ± -	PRODUCT SPEC	
	3 PLC ± .005 [0.13]	APPLICATION SPEC	
MATERIAL: SEE TABLE	FINISH: SEE TABLE	NAME: D.MILLER	TE Connectivity PIN CONTACT ASSY, SIZE 20 (20-24 AWG)
		WEIGHT: -	SIZE: A2 CAGE CODE: 00779 DRAWING NO: C-203816 RESTRICTED TO: -
		CUSTOMER DRAWING	SCALE: 10:1 SHEET: 1 of 1 REV: Y