

THIS DRAWING IS UNPUBLISHED. RELEASED FOR PUBLICATION
 © COPYRIGHT - By - ALL RIGHTS RESERVED.

LOC		DIST		REVISIONS			
P	LTR	DESCRIPTION		DATE	DWN	APVD	
GP	00	P		REVISED PER ECO-11-004835	11MAR11	RK	HMR

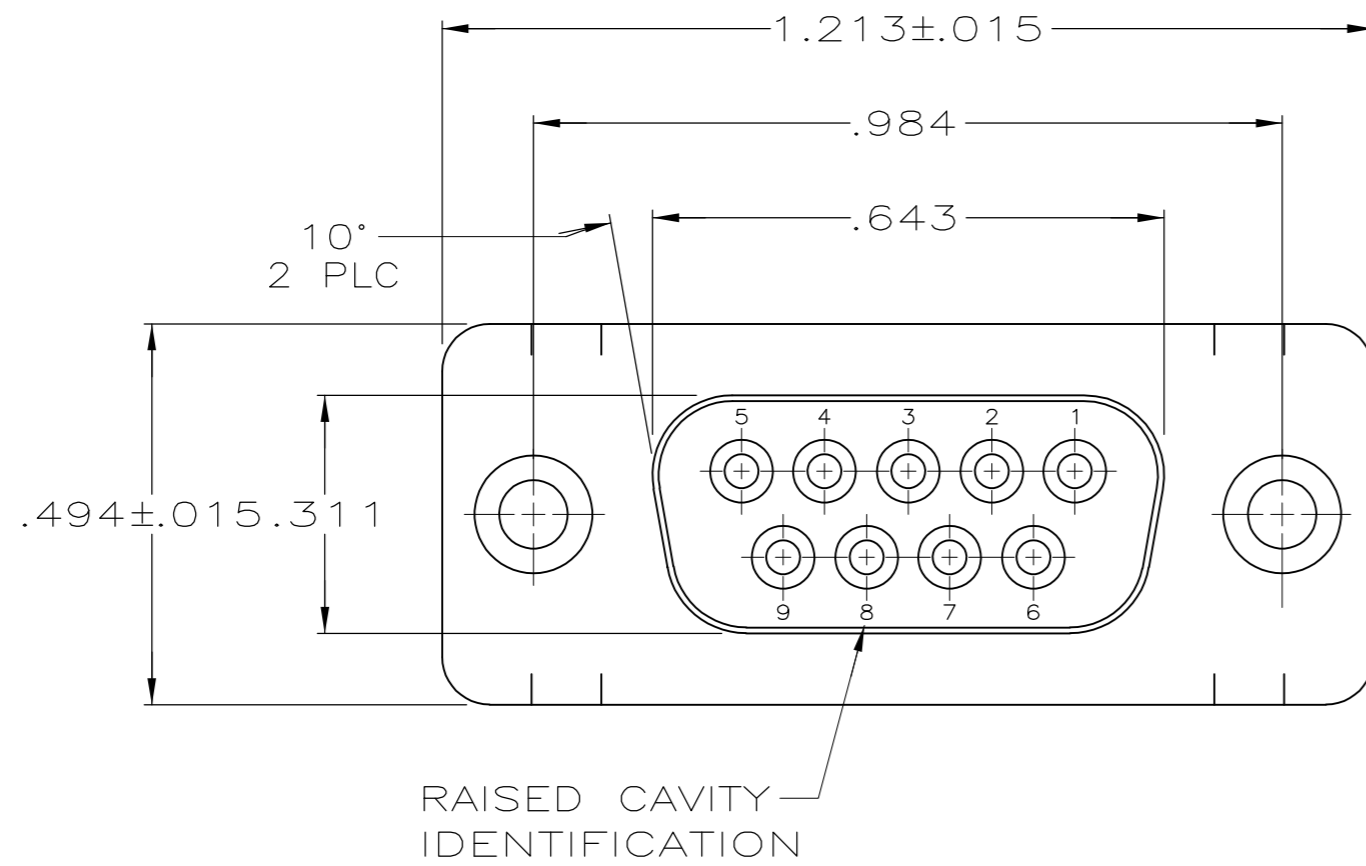

- 1. CONNECTOR ACCEPTS SIZE 20 DF SOCKET CONTACTS, RETENTION TINES ARE AN INTEGRAL PART OF INSERT.
- 2. FLAME RETARDANT 94V-0 RATED THERMOPLASTIC; COLOR: BLACK.
- 3. STEEL PER ASTM A109.
- 4. .000200 MIN TIN PLATE OVER .000100 MIN COPPER UNDERPLATE.

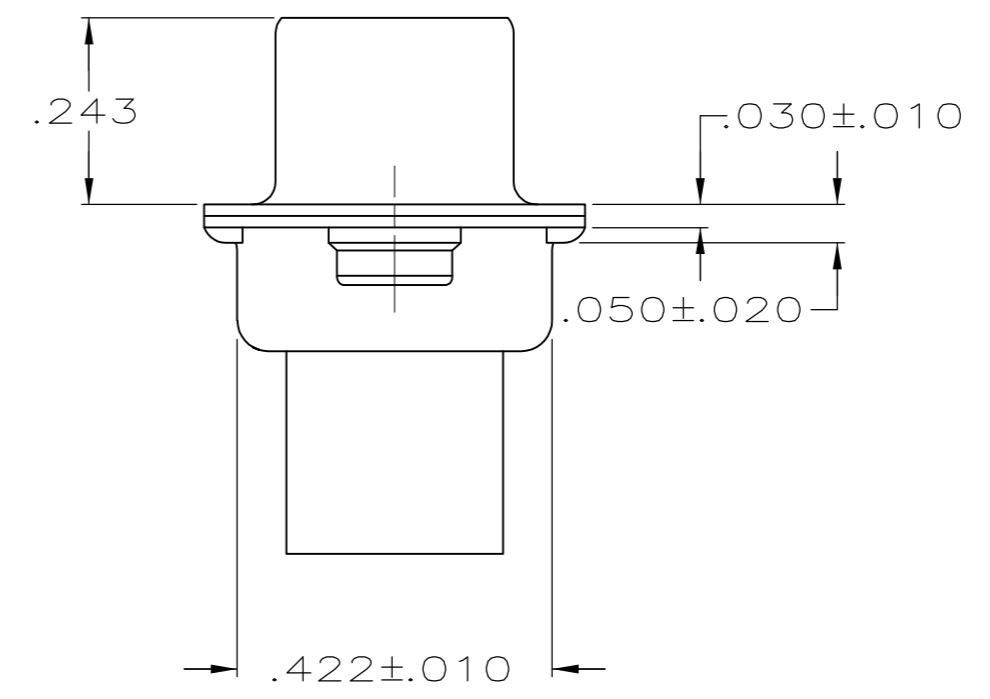
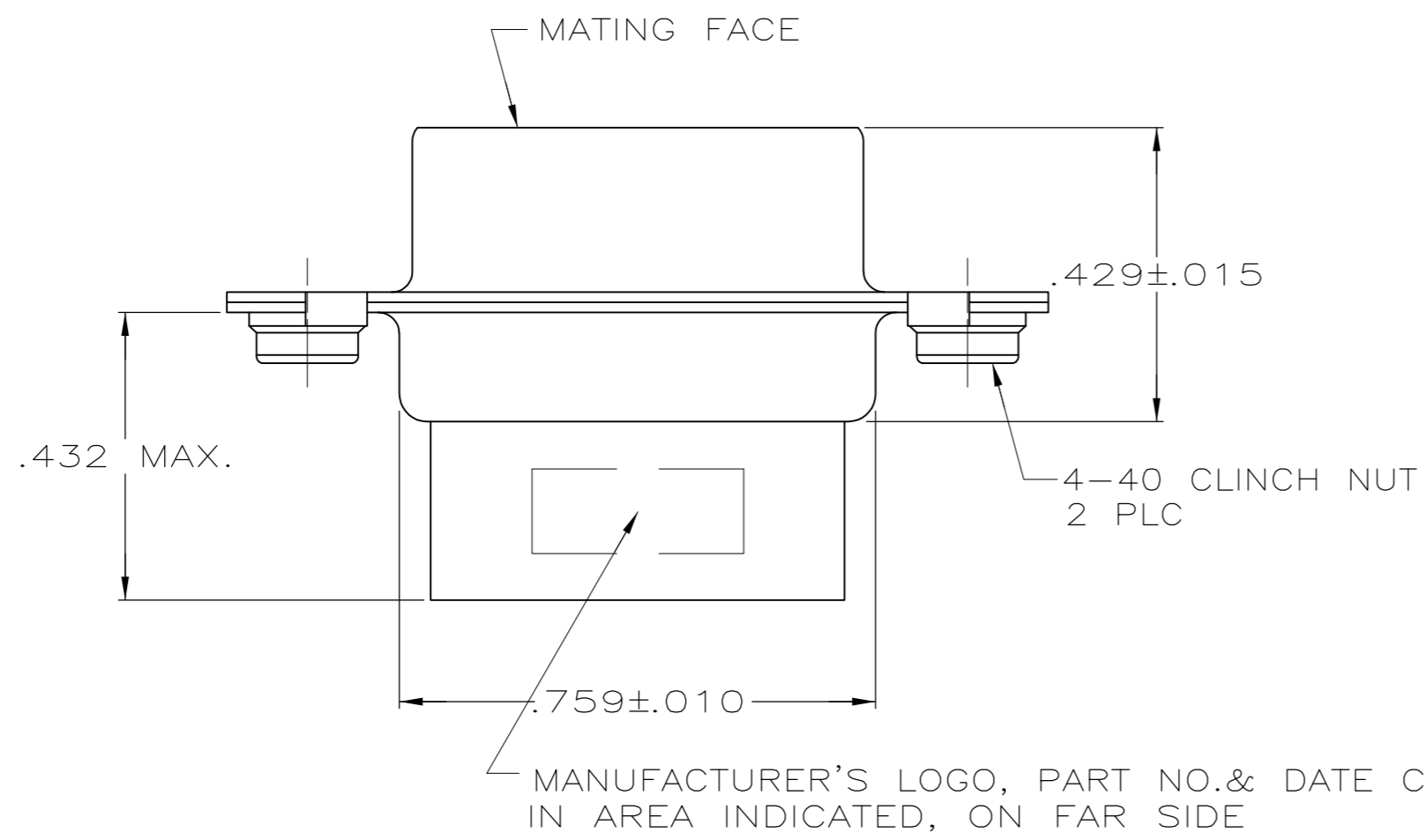

1658643-1
PART NUMBER

THIS DRAWING IS A CONTROLLED DOCUMENT.		DWN	J. REITZEL	30JUL03		TE Connectivity		
DIMENSIONS: INCHES		CHK	S. BOLASH	30JUL03		NAME		
TOLERANCES UNLESS OTHERWISE SPECIFIED:		APVD	M. WALMSLEY	30JUL03		RECEPTACLE CONNECTOR, SIZE 1, 9 POSN, WITH CLINCH NUTS, AMPLIMITE HDP		
0 PLC ± - 1 PLC ± - 2 PLC ± - 3 PLC ± .005 4 PLC ± - ANGLES ± 2° FINISH		PRODUCT SPEC	108-40005			SIZE	CAGE CODE	DRAWING NO
MATERIAL		APPLICATION SPEC	114-40030		RESTRICTED TO	-		
MOLDED PARTS: 2 SHELLS: 3		WEIGHT	-		SCALE	4:1		
SHELLS: 4		CUSTOMER DRAWING	A2 00779 C-1658643		SHEET	1 of 1		
					REV	P		