



PRODUCT SPECIFICATION

DOCUMENT NO. ENS000143620

DESCRIPTION	DRAWN BY	DESIGNED BY	CHECKED BY	APPROVED BY
TVL 0201 01 3V AA0DG	Eric	Eric	Anderson	Shawn

TVL0201 01 3V AA0DG Product Engineering Specification

1. Scope

TVL 0201 01 3V AA0 is a TVS diode designed to protect one power/control line or one low speed signal line from overvoltage hazard of Electrostatic Discharge (ESD).

These interfaces can be used in computer interfaces protection, microprocessors protection, serial and parallel ports protection, control signal lines protection, power lines on PCB protection, latch-up protection. The actual application examples are USB2.0, VBUS, and VGA, etc. The ESD protection of TVS meets the immunity standard of IEC 61000-4-2, level 4 ($\pm 25\text{kV}$ air, $\pm 25\text{kV}$ contact discharge).

2. Explanation of Part Number

<u>TV</u>	<u>L</u>	<u>0201</u>	<u>01</u>	<u>3V</u>	<u>AA0</u>	<u>DG</u>
(1)	(2)	(3)	(4)	(5)	(6)	(7)

- (1) Product Type : TV=TVS Diode
- (2) Capacitance Code : L=Low Capacitance
- (3) Package Code
- (4) Channel Code : 01=1 Channels
- (5) Working Voltage
- (6) Special code
- (7) Inpaq Control Code

3. Circuit Diagram & Dimension

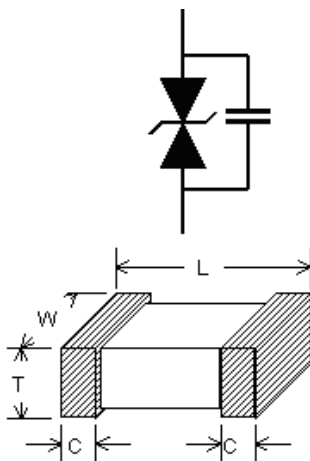

Unit: mm	0201
L	0.60 \pm 0.05
W	0.30 \pm 0.04
T	0.30 \pm 0.04
C	0.20 \pm 0.06

4. Specifications

4.1. Absolute Maximum Ratings

Parameter	Symbol	Rating	Units
Operating Supply Voltage	V_{DC}	3	V
Peak Pulse Current (8/20 μ s)	I_{PP}	8	A
ESD per IEC 61000-4-2 (Air)	V_{ESD}	± 25	kV
ESD per IEC 61000-4-2 (Contact)		± 25	
Lead Soldering Temperature	T_{SOL}	260 (10 sec.)	$^{\circ}C$

4.2. Electrical Characteristics

Parameter	Symbol	Conditions	Min	Typ	Max	Units
Reverse Stand-Off Voltage	V_{RWM}	$T=25^{\circ}C$.		3	3.3	V
Reverse Leakage Current	I_{Leak}	$V_{RWM} = 5V, T=25^{\circ}C$.			1	μA
Reverse Breakdown Voltage	V_{BV}	$I_{BV} = 1mA, T=25^{\circ}C$.	4.7	6.7	8.7	V
Clamping Voltage	V_{TLP}	$I_{TLP} = 1A$ (100ns transmission line) $I_{TLP} = 16A$ (100ns transmission line)		5.4 6.3		
Channel Input Capacitance	C_{IN}	$V_R = 0V, f = 1MHz, T=25^{\circ}C$.		11.5	13.5	pF

4.3. Typical Characteristics

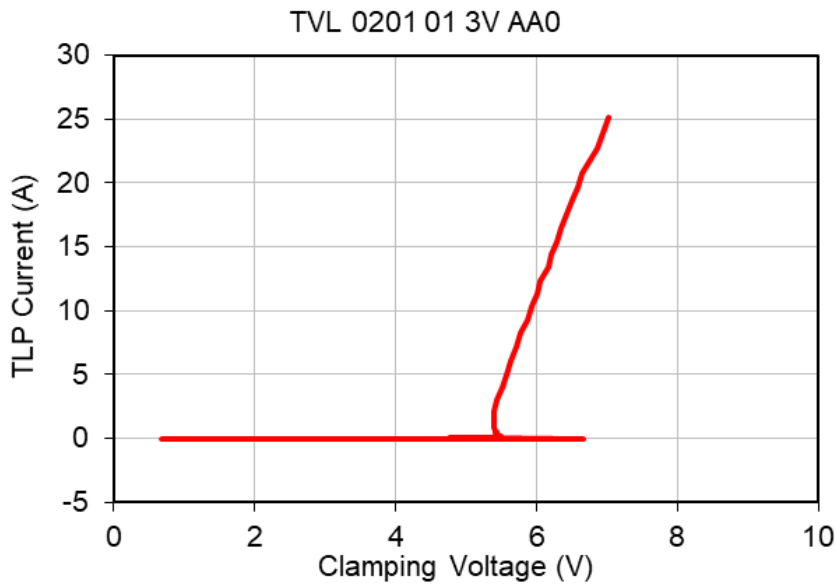

5. Taping Package and Label Marking

5.1. Packaging Method (Material: paper)

Products shall be heat-sealed in the chip pocket, spacing pitch 4-mm of paper carrier tape with plastic cover tape, and the carrier tape shall be reeled to the reel.

5.2. Carrier Tape Dimensions

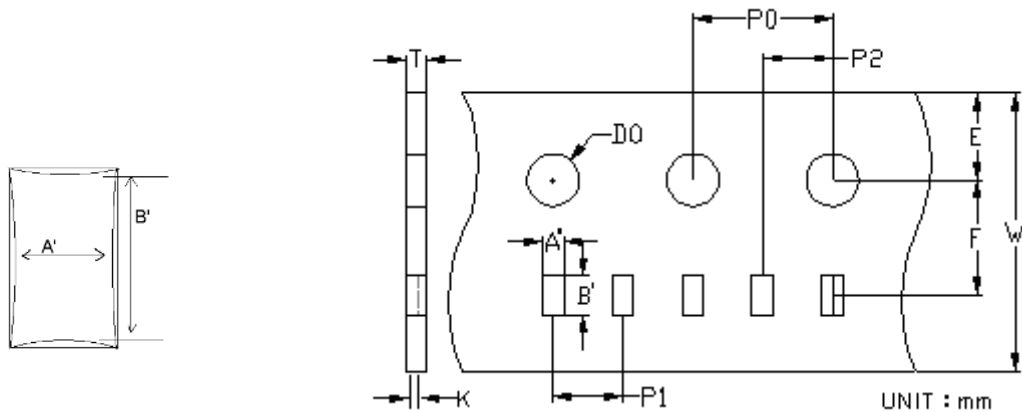

Type	A'	B'	W	E	F	P0	P1	P2	D0	T	K
0201	0.35 ±0.02	0.67 ±0.02	8.0 ±0.1	1.75 ±0.05	3.5 ±0.05	4.0 ±0.03	2.0 ±0.03	2.0 ±0.03	1.55 ±0.05	0.42 ±0.03	0.35 ±0.02

5.3. Taping Reel Dimensions

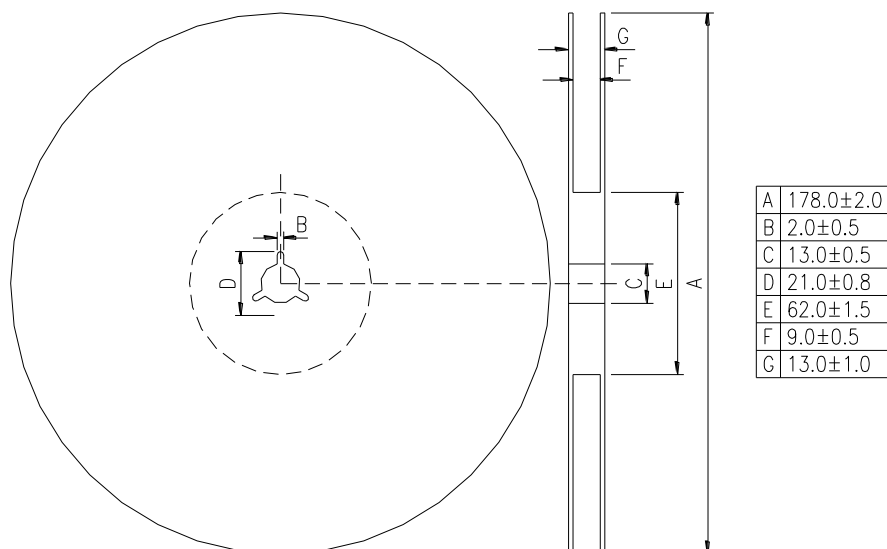

Unit: mm

5.4. Taping Specifications

There shall be the portion having no product in both the head and the end of taping, and there shall be the cover tape in the head of taping.

5.5. Label Marking

The label specified as follows shall be put on the side of reel.

(1) Part No.

(2) Quantity

(3) Lot No.

*Part No. And Quantity shall be marked on outer packaging.

5.6. Quantity of Products in the Taping Package

(1) Standard quantity : 15000pcs/Reel for TVL0201 Series

(2) Shipping quantity is a multiple of standard quantity.

5.7. Storage Condition with Package

Storage Time: 12 months max

Storage Temperature : 5 to 40°C

Relative Humidity: 0 to 60 %

6. Precautions for Handling

6.1. Solder Cream in Reflow Soldering

Refer to the recommendable land pattern as printing mask pattern for solder cream.

- (1) Print solder in a thickness of 150 to 200 μm .
- (2) Dimensions: millimeters (inches)

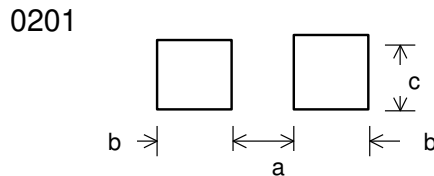

Unit: mm

Type	a	b	c
0201	0.2~0.3	0.25~0.30	0.3~0.4

Notes: This LAND LAYOUT is for reference purposes only. Please consult your manufacturing partners to ensure your company's PCB design guidelines are met.

6.2. Precaution for Handling of Substrate

Do not exceed to bend the board after soldering this product extremely.

(Reference examples)

- Mounting place must be as far as possible from the position, which is close to the break line of board, or on the line of large holes of board.
- Do not bend extremely the board, in mounting other components.
If necessary, use back-up pin (support pin) to prevent from bending extremely.
- Do not break the board by hand. We recommend using the machine or the jig to break it.

6.3. Precaution for Soldering

Note that rapid heating, rapid cooling or local heating will easily damage this product.

Do not give heat shock over 100°C in the process of soldering. We recommend taking preheating and gradual cooling.

6.4. Recommendable Reflow Soldering

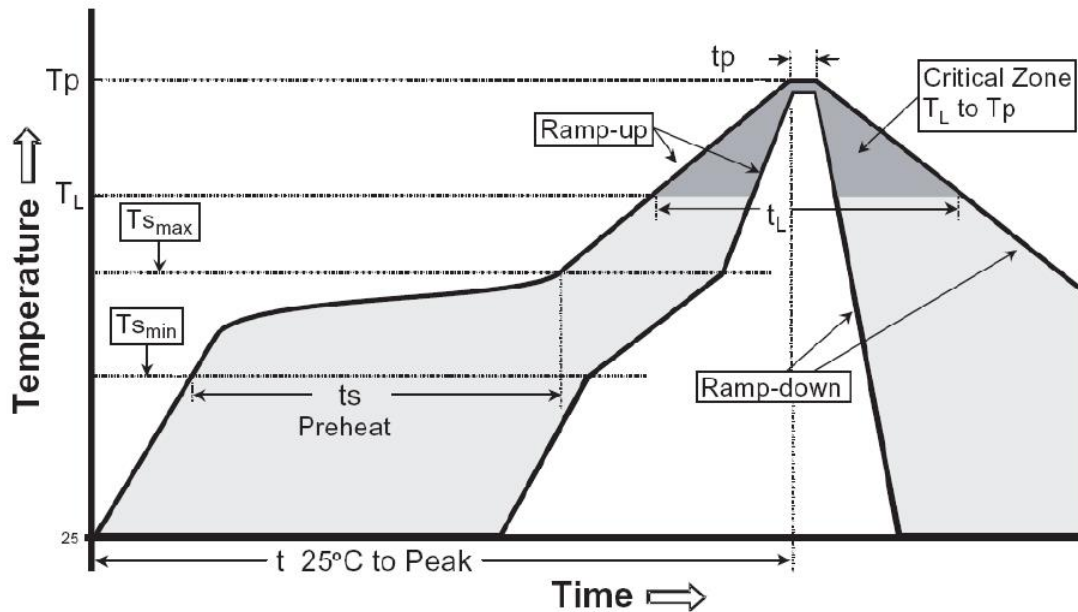

Profile Feature	Pb free Assembly
Average Ramp Rate ($T_{s_{max}}$ to T_p)	3°C/second max
Preheat	
- Temperature Min ($T_{s_{min}}$)	150°C
- Temperature Min ($T_{s_{max}}$)	200°C
- Time($t_{s_{min}}$ to $t_{s_{min}}$)	60-180 seconds
Time maintained above:	
- Temperature (T_L)	217°C
- Time (t_L)	60-150 seconds
Peak Temperature (T_p)	260°C +0/-5 °C
Time within 5°C of actual Peak Temperature (T_p)	Max 10 seconds.
Ramp-Down Rate	6°C/second max.
Time 25°C to Peak Temperature	8 minutes max

*According to J-STD-020C

6.5. Soldering Gun Procedure

Note the follows, in case of using solder gun for replacement.

- (1) The tip temperature must be less than 330°C for the period within 6 seconds by using soldering gun less than 30 W.
- (2) The soldering gun tip shall not touch this product directly.

6.6. Soldering Volume

Note that excess of soldering volume will easily get crack the body of this product.

6.7. MSL Level:

Level 1