

LOC	DIST	REV	DATE	BY	CHK	APPD	DESCRIPTION
IN	00						
		A	18JAN2008	RGV			RELEASED PER ECO-08-001177
		A1	31JUL2008	DLD			REVISED PER ECO-08-018839
		A2	05MAR2009	DLD			REVISED PER ECO-09-009935

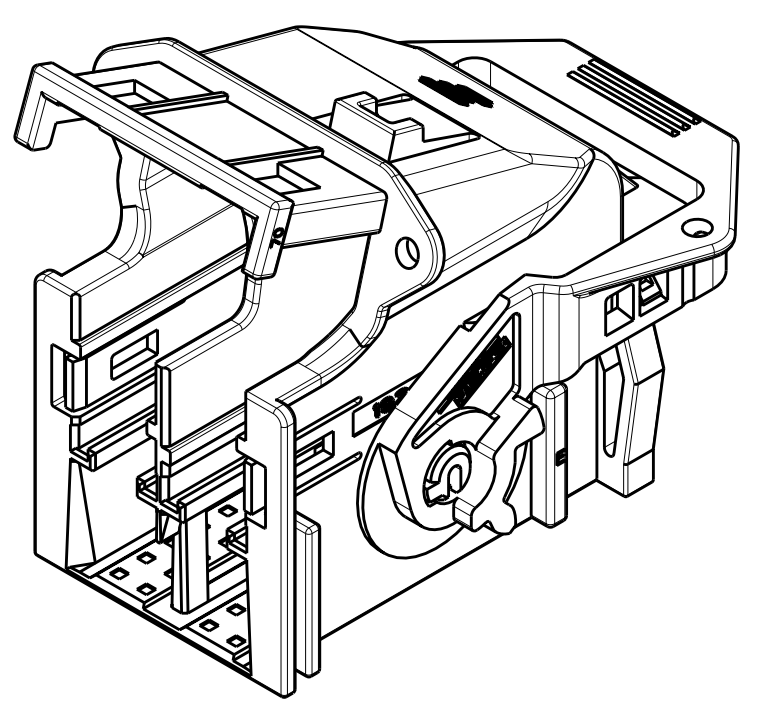

SCALE 2:1

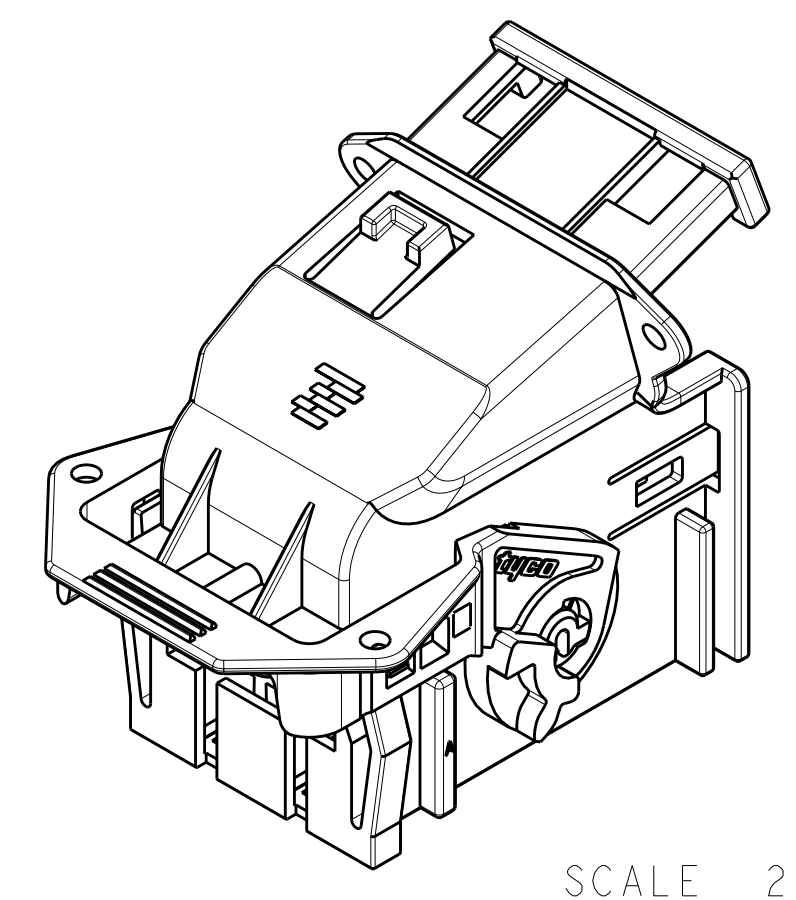
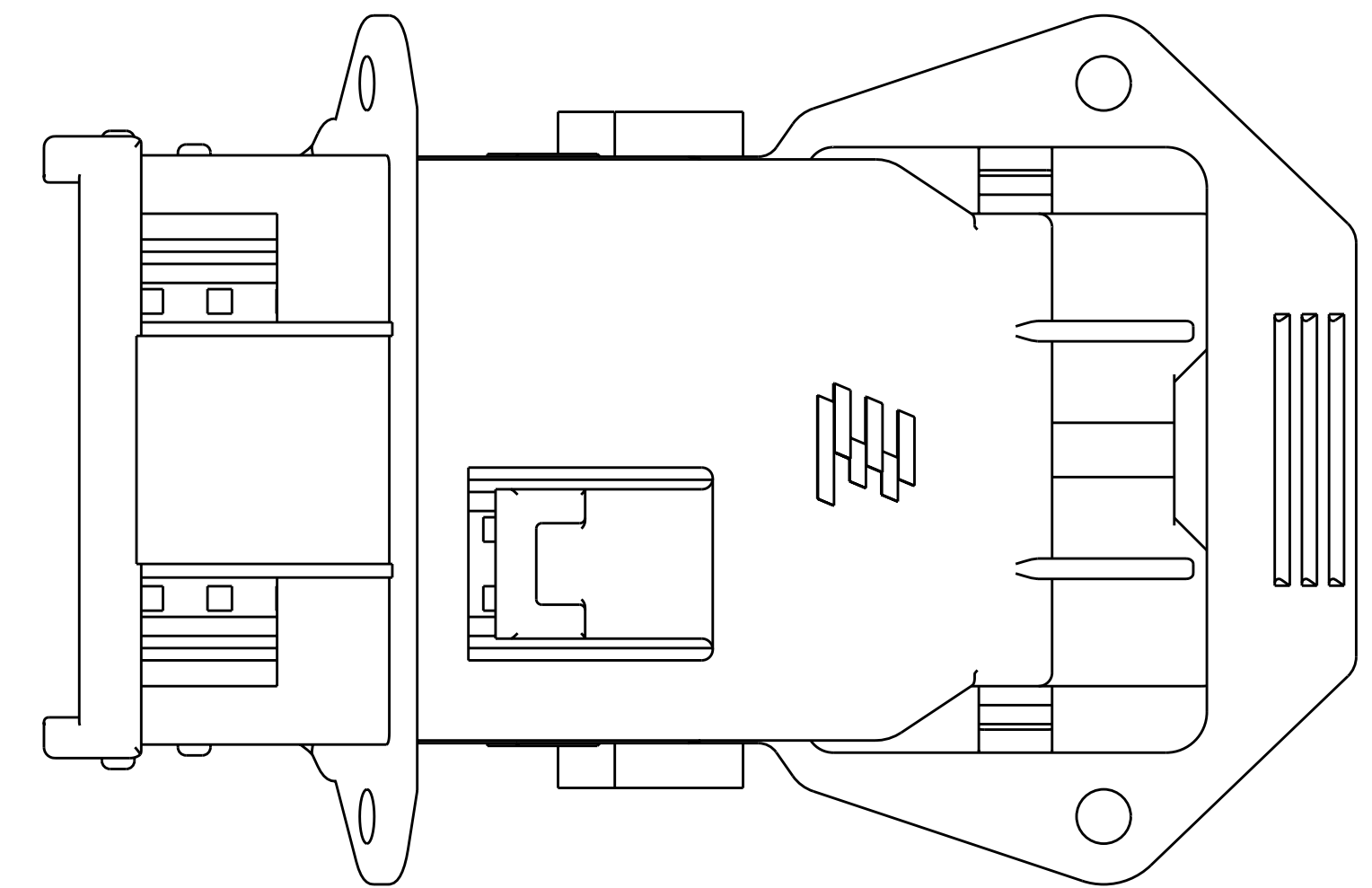

SCALE 2:1

- △ MATERIAL: SHIELD - 35% GLASS REINFORCED NYLON. SEE TABLE BELOW FOR COLOR.
LEVER - 35% GLASS REINFORCED NYLON. COLOR: DARK GREY.
- REFERENCE: RECEPTACLE HOUSING, 1924136-1 & 1924136-2, USED WITH THIS ASSEMBLY.
 - REFERENCE: INTERFACE DETAIL PER DRAWING NO. AAU01000-2962-0010 AND TE DRAWING NO. 1438985-GEN.

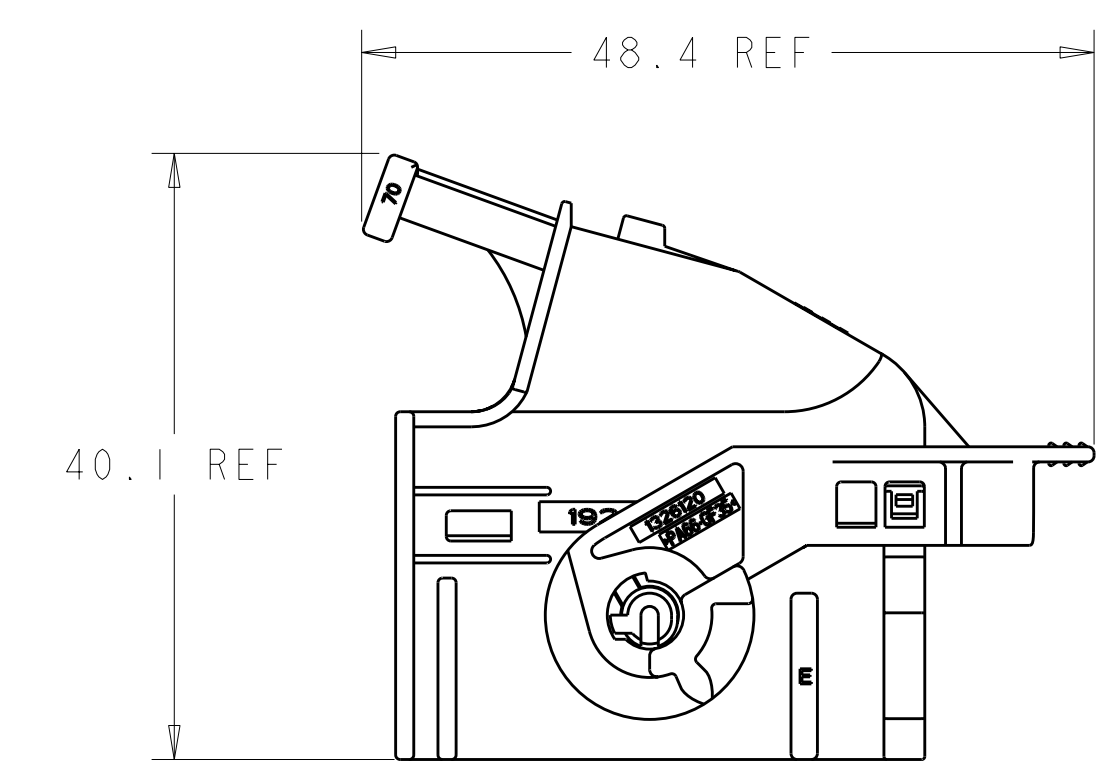
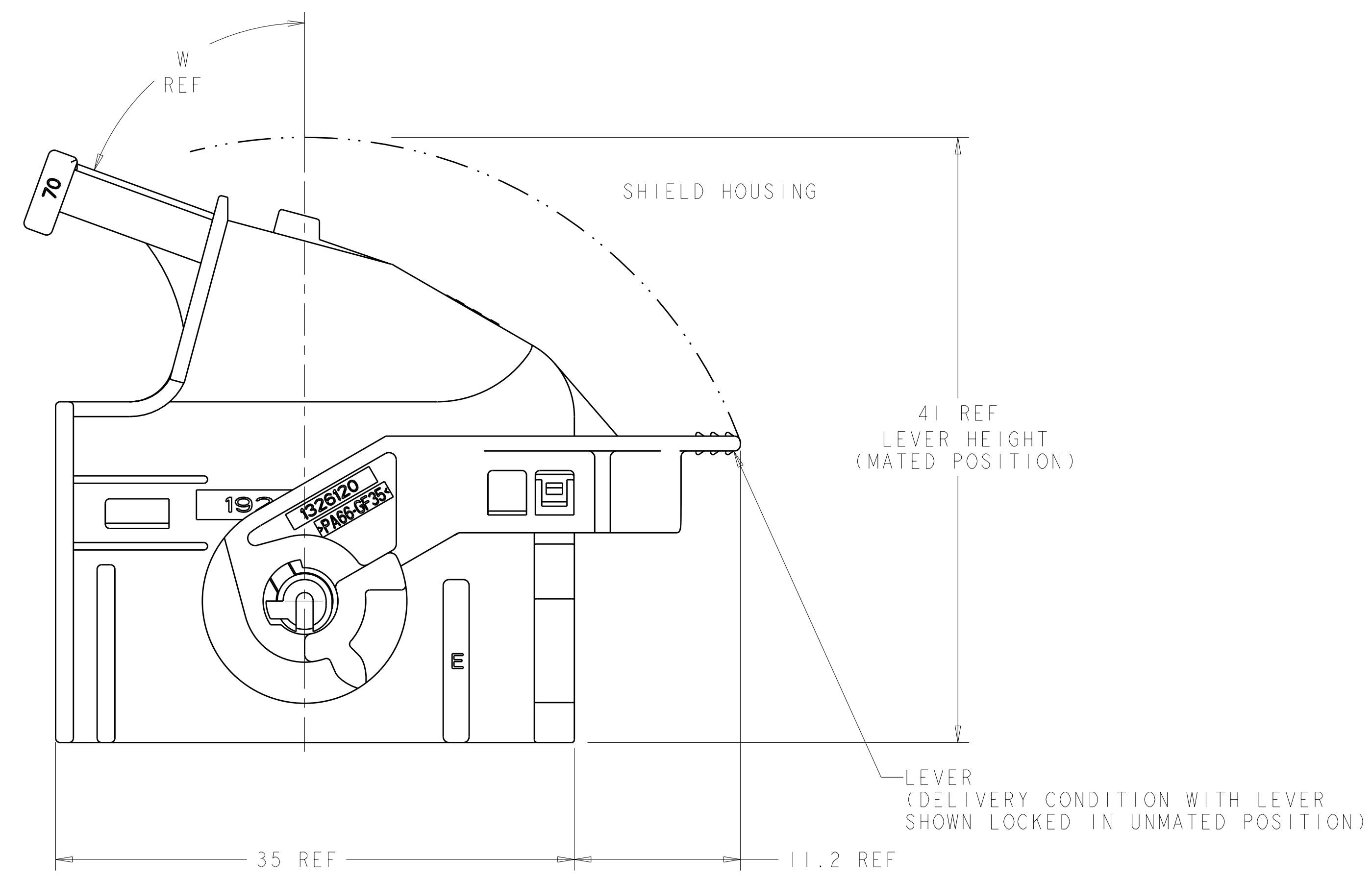
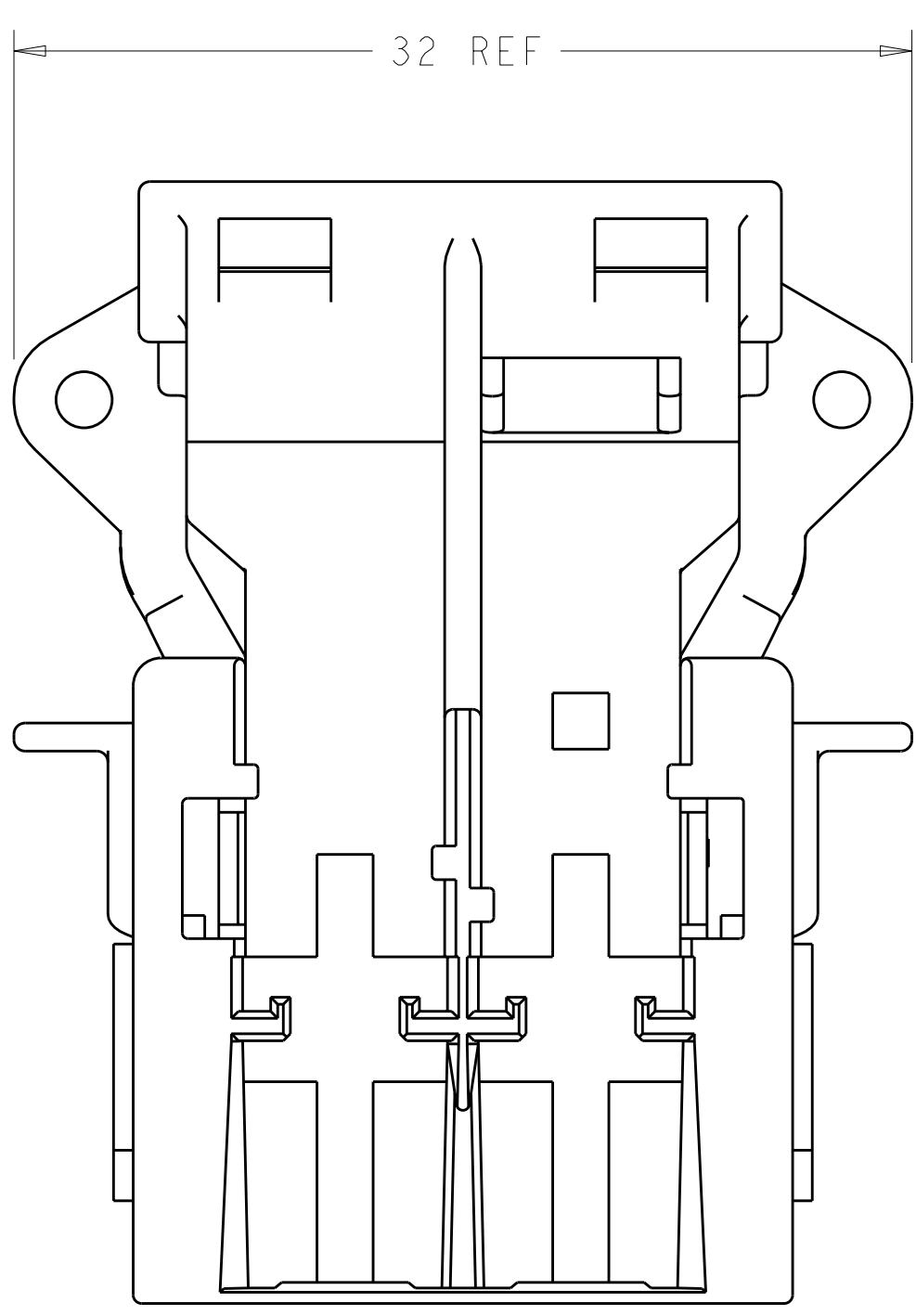

70° WIRE EXIT SCALE 2:1

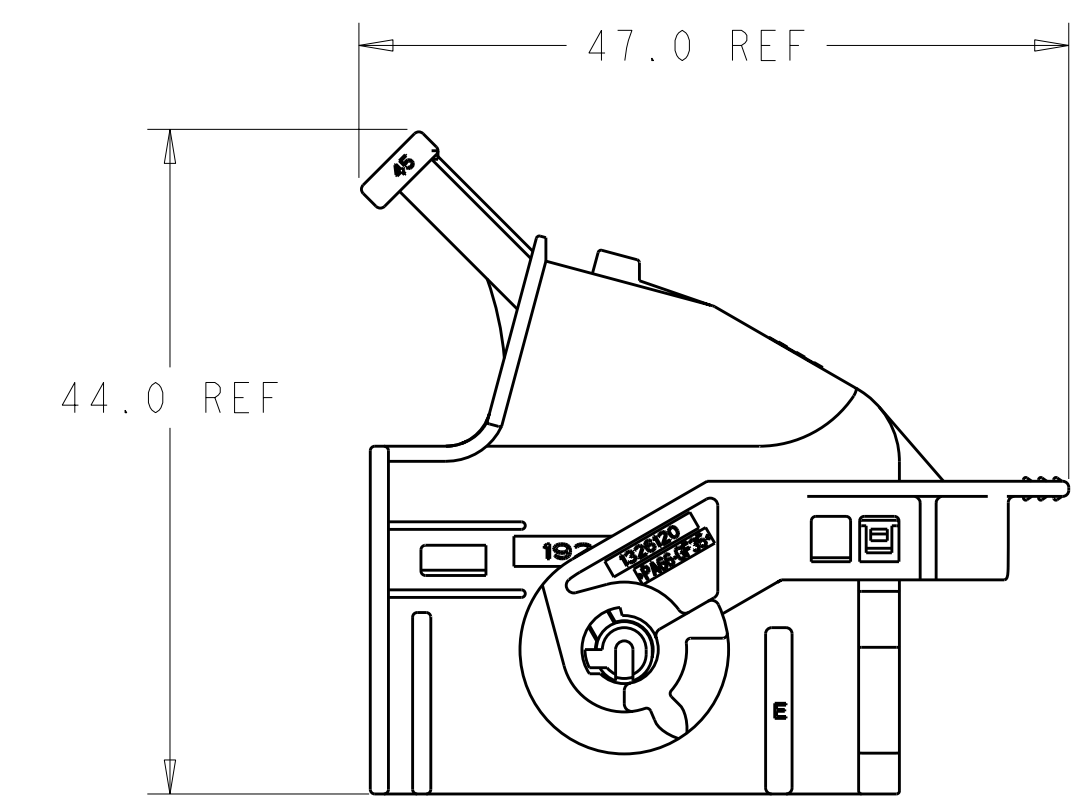

45° WIRE EXIT SCALE 2:1

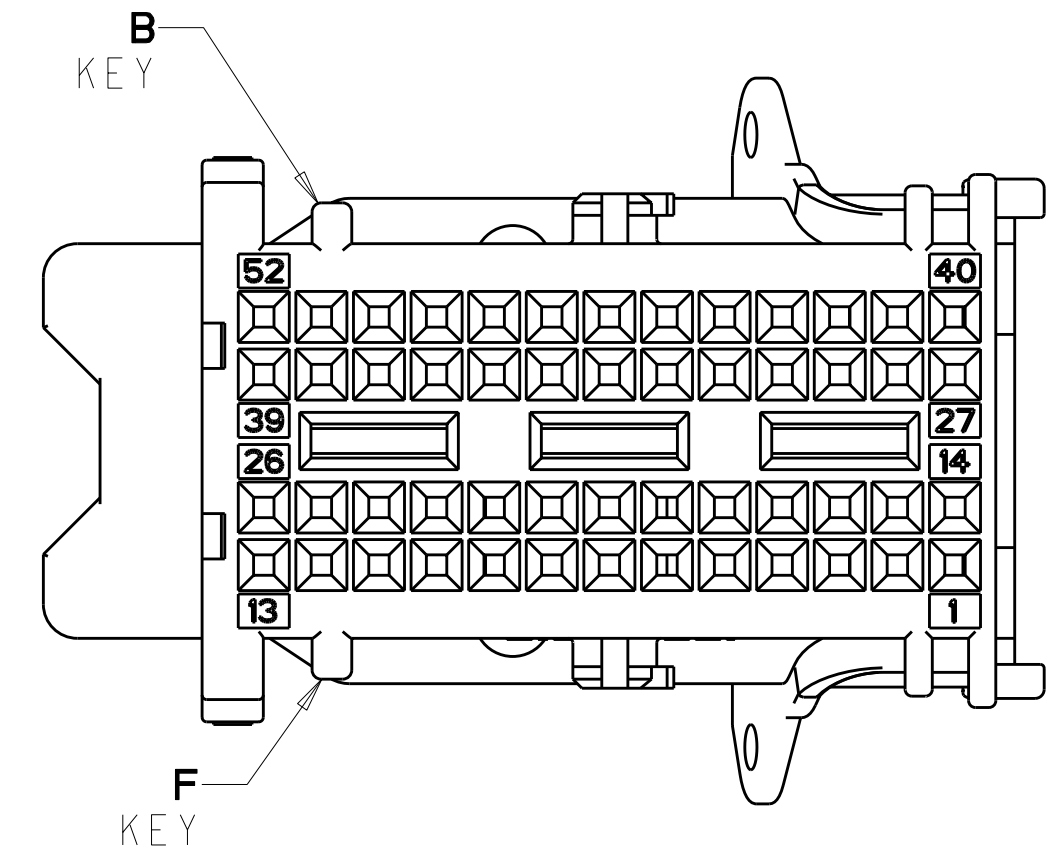

KEY B-F SHOWN FOR ASSEMBLY 1924346-3 & 1924346-6

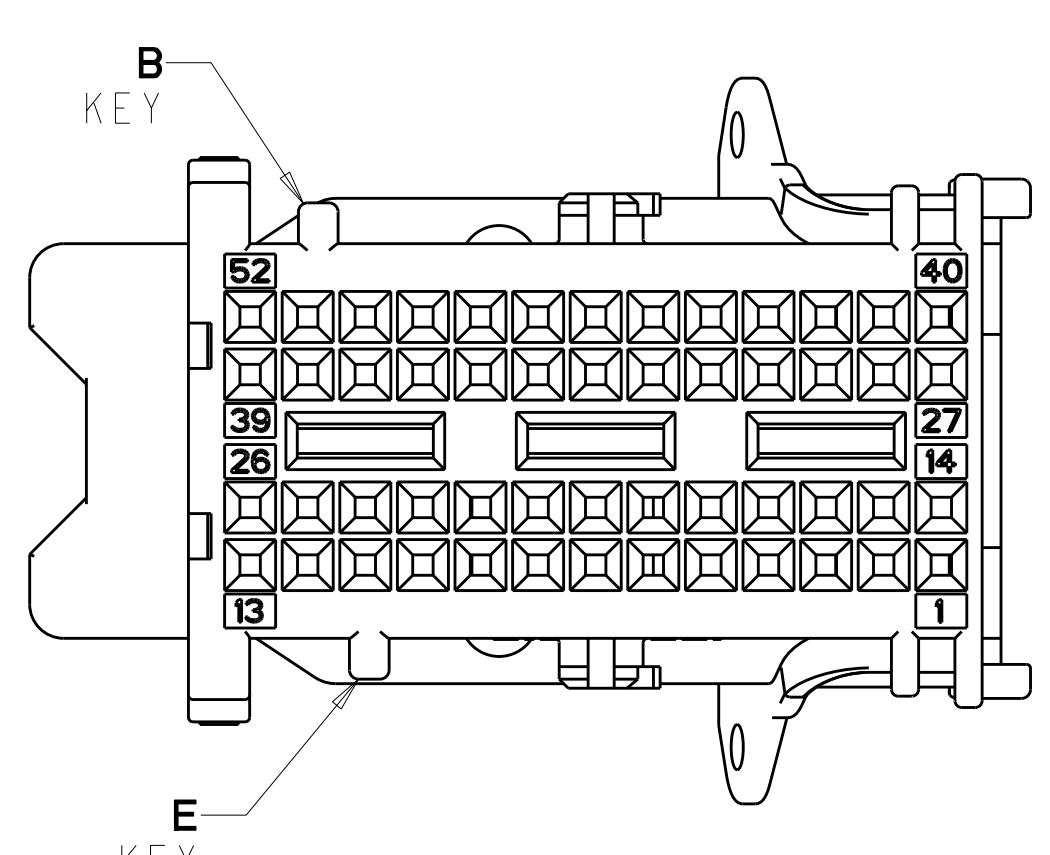

KEY B-E SHOWN FOR ASSEMBLY 1924346-2 & 1924346-5

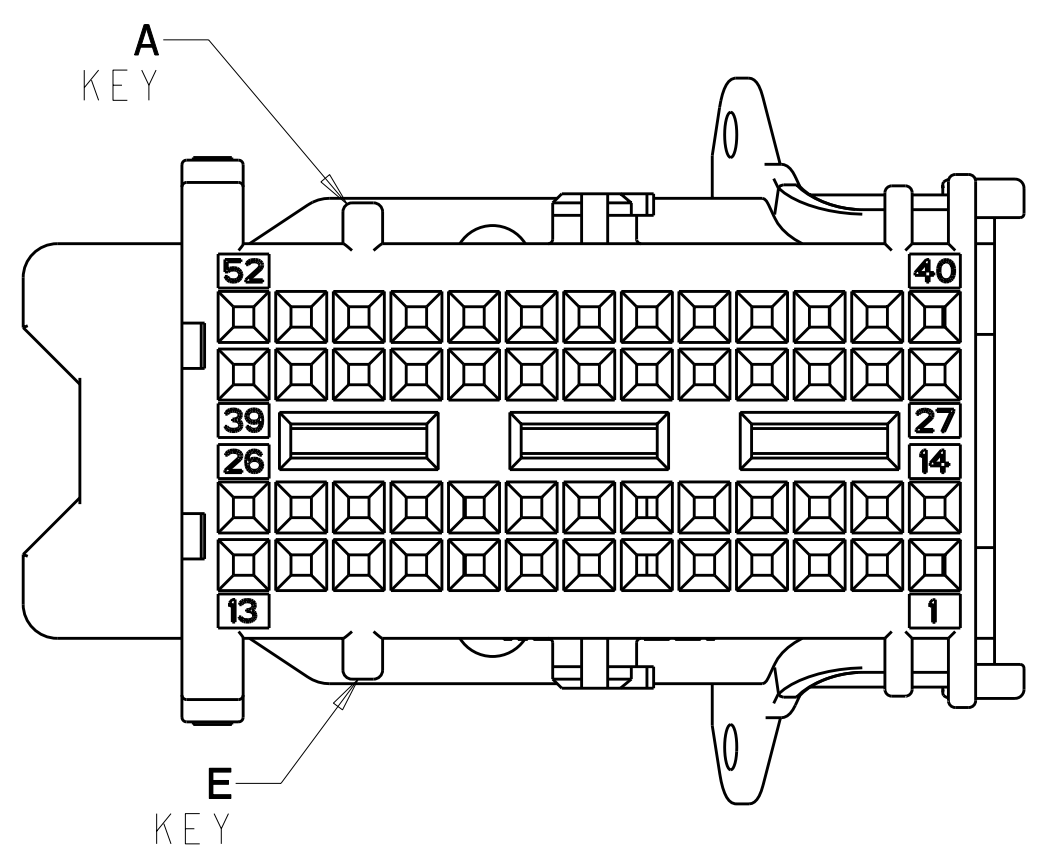

KEY A-E SHOWN FOR ASSEMBLY 1924346-1 & 1924346-4

DIM W	COLOR	KEYING OPT.	PART NUMBER
45°	BLUE	B-F	1924346-6
45°	GRAY	B-E	1924346-5
45°	BLACK	A-E	1924346-4
70°	BLUE	B-F	1924346-3
70°	GRAY	B-E	1924346-2
70°	BLACK	A-E	1924346-1

DIMENSIONS: mm TOLERANCES UNLESS OTHERWISE SPECIFIED: 9 PLC ±0.2 1 PLC ±0.25 3 PLC ±0.5 4 PLC ±0.5 ANGLES ±0.5° FINISH: △		DWN: FOLTZ 24OCT2007 CHK: G. MARTIN 24OCT2007 APPD: G. MARTIN 24OCT2007 PRODUCT SPEC: - APPLICATION SPEC: - WEIGHT: - CUSTOMER DRAWING: -	Tyco Electronics Harrisburg, PA 17105-3608 NAME: SHIELD ASSEMBLY, 52 POSITION, LEVER ASSISTED, 0.64mm GENERATION Y, CONNECTOR SIZE: A1 CAGE CODE: 00779 DRAWING NO: C=1924346 SCALE: 4:1 SHEET: 1 OF 2 REV: A2
------------------------------------------------------------------------------------------------------------------------------------------------	--	-------------------------------------------------------------------------------------------------------------------------------------------------------------	----------------------------------------------------------------------------------------------------------------------------------------------------------------------------------------------------------------------------------------

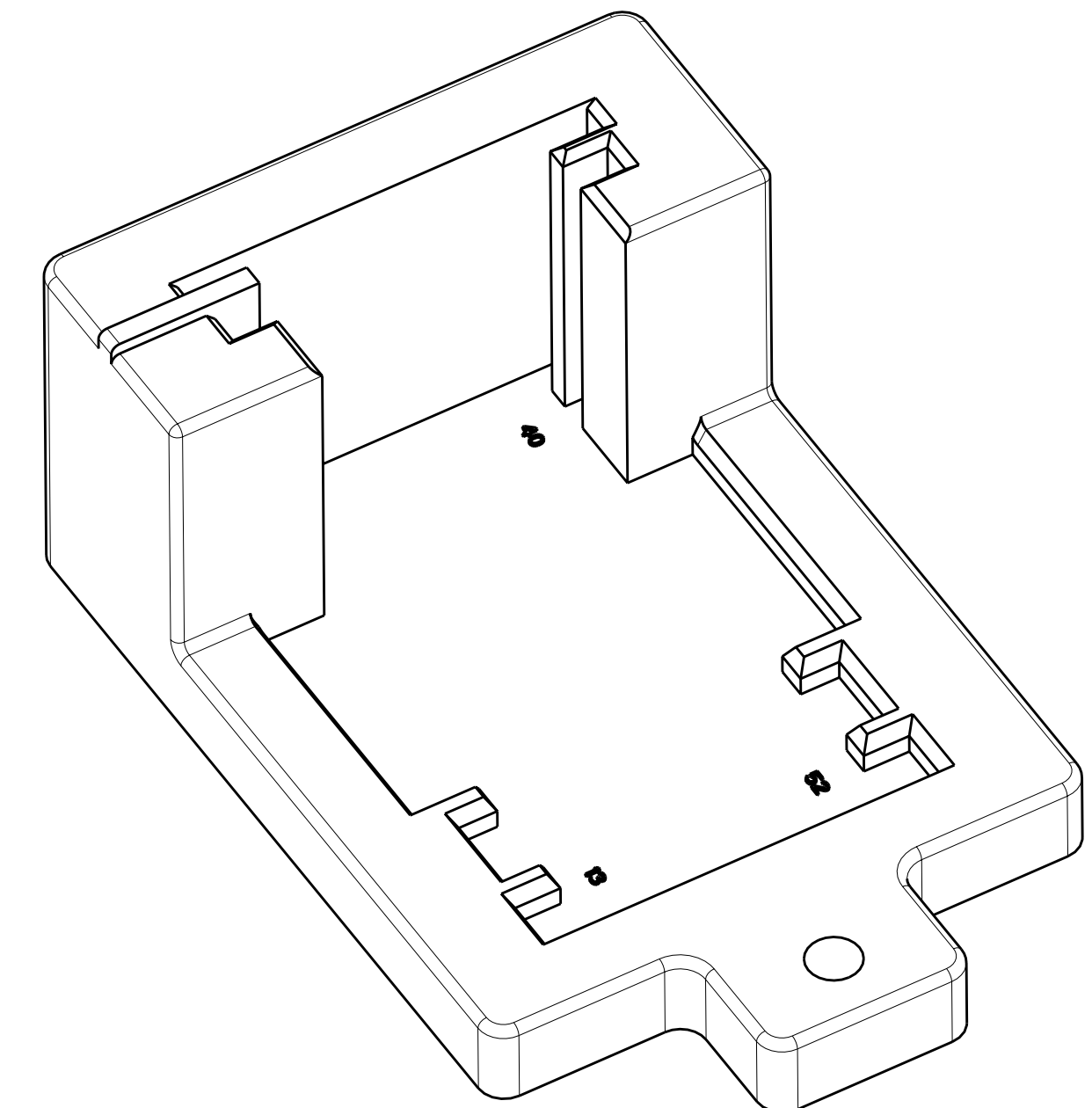
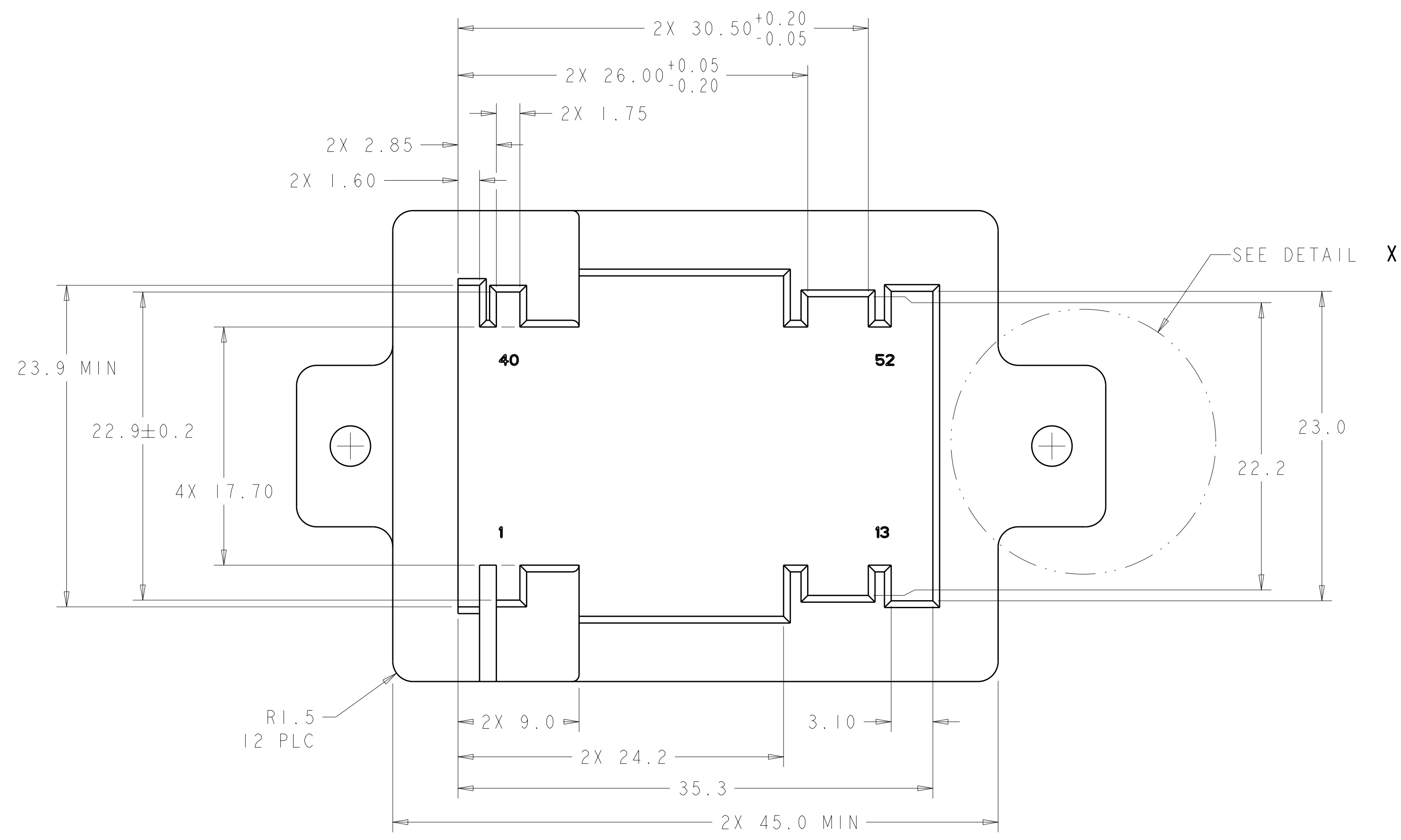

SCALE 3:1

LOC	DIST	REV	DESCRIPTION	DATE	OWN	APVD
IN	00		SEE SHEET 1			

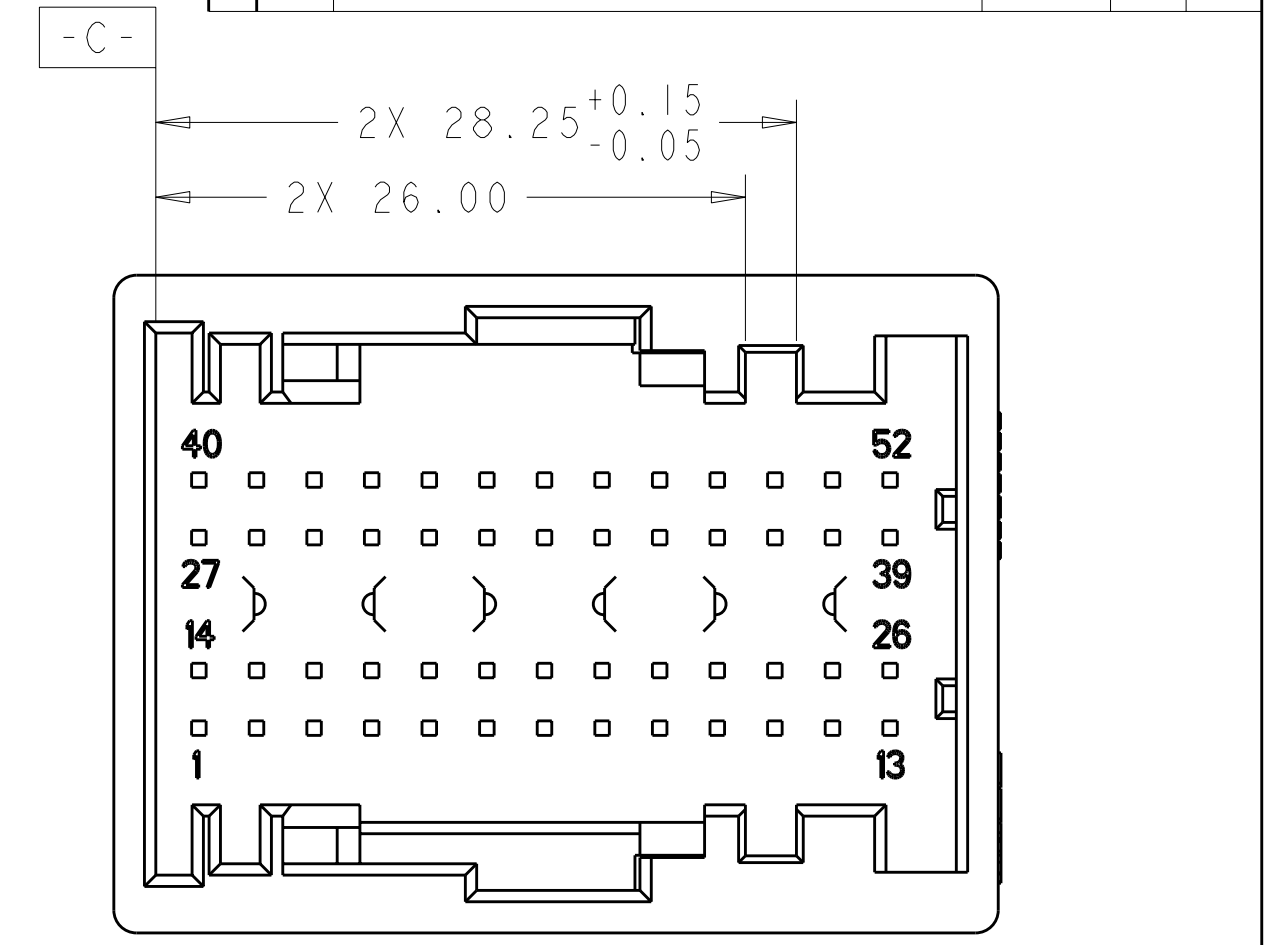

KEY OPTION A-E

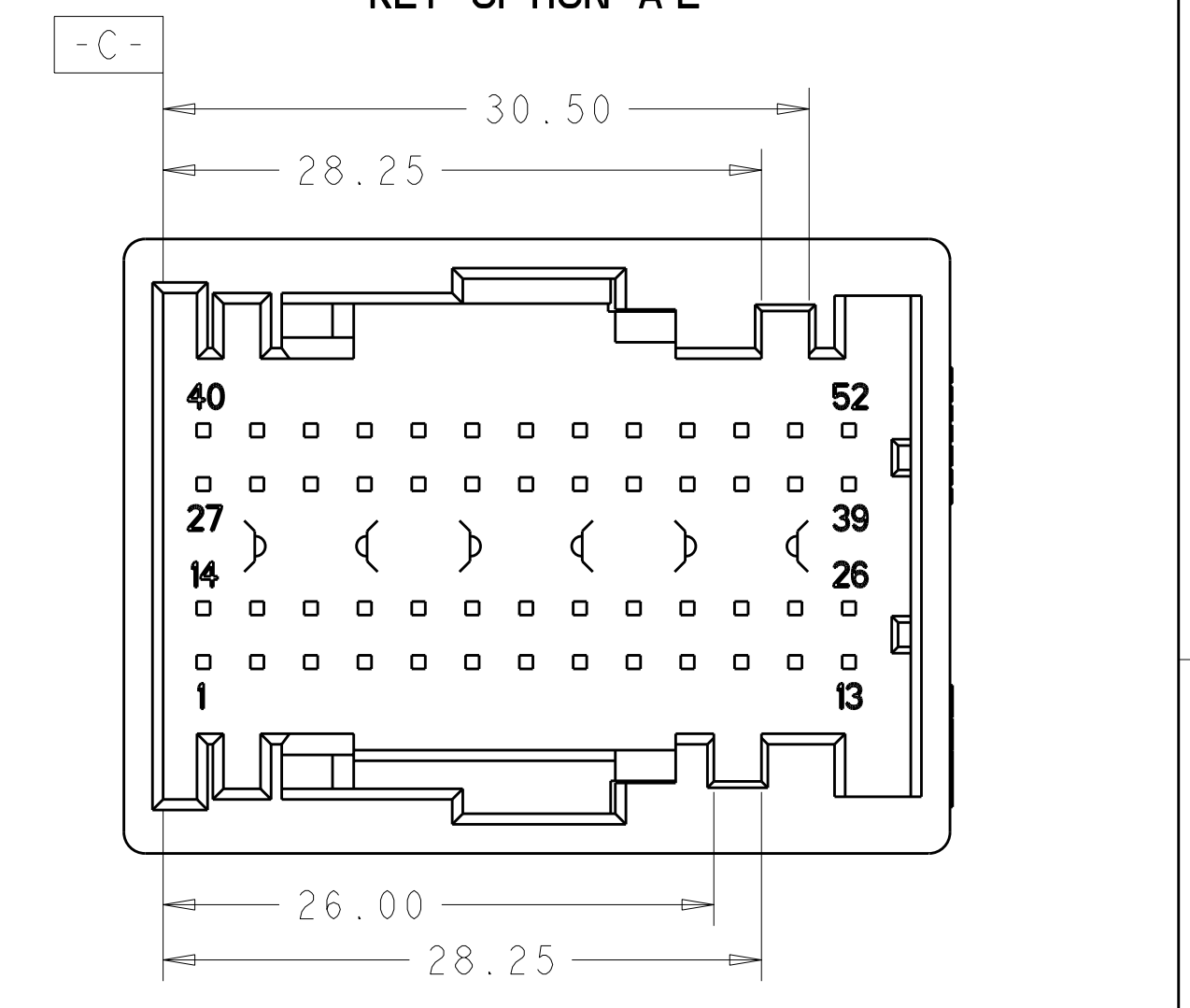

KEY OPTION B-E

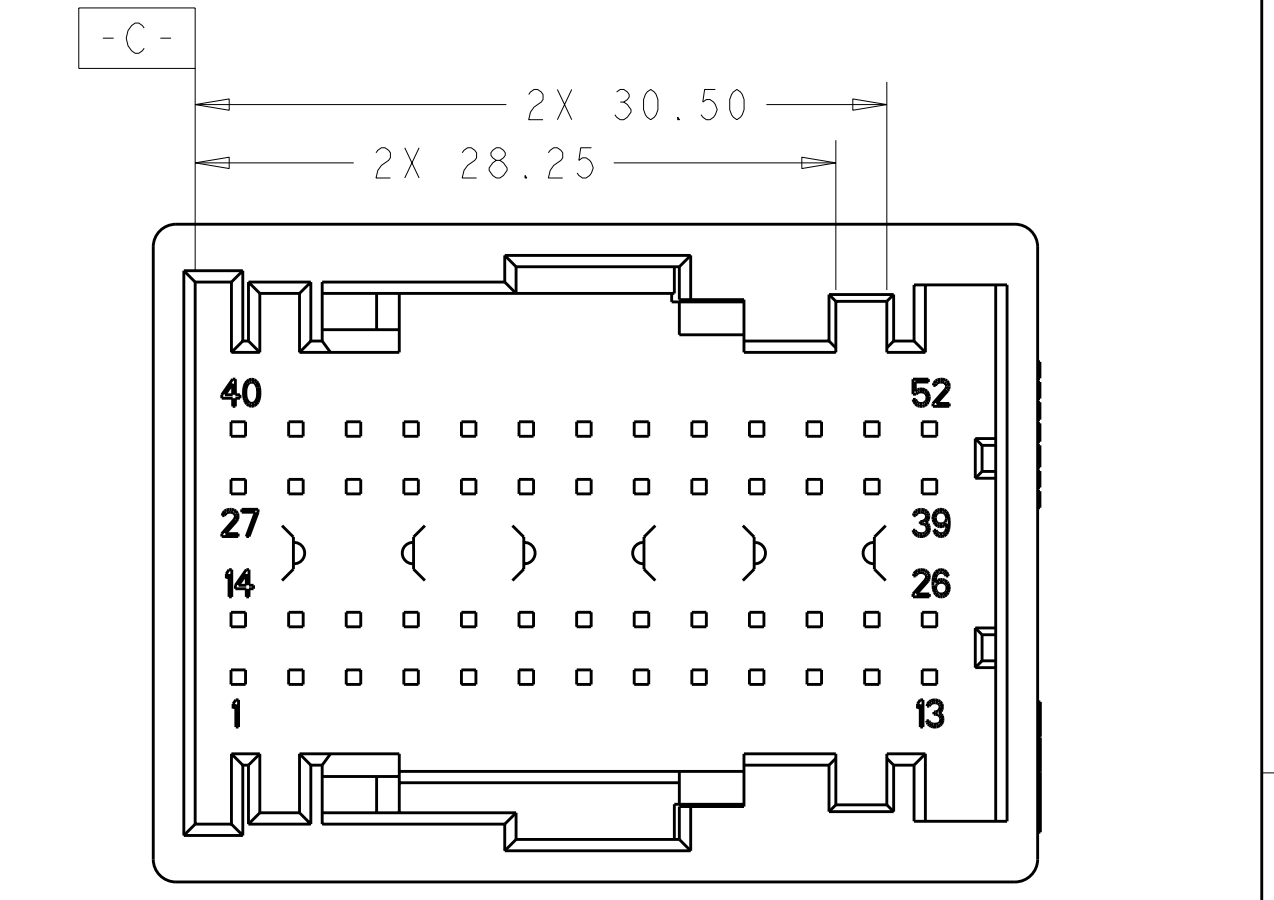

KEY OPTION B-F

KEYING OPTIONS

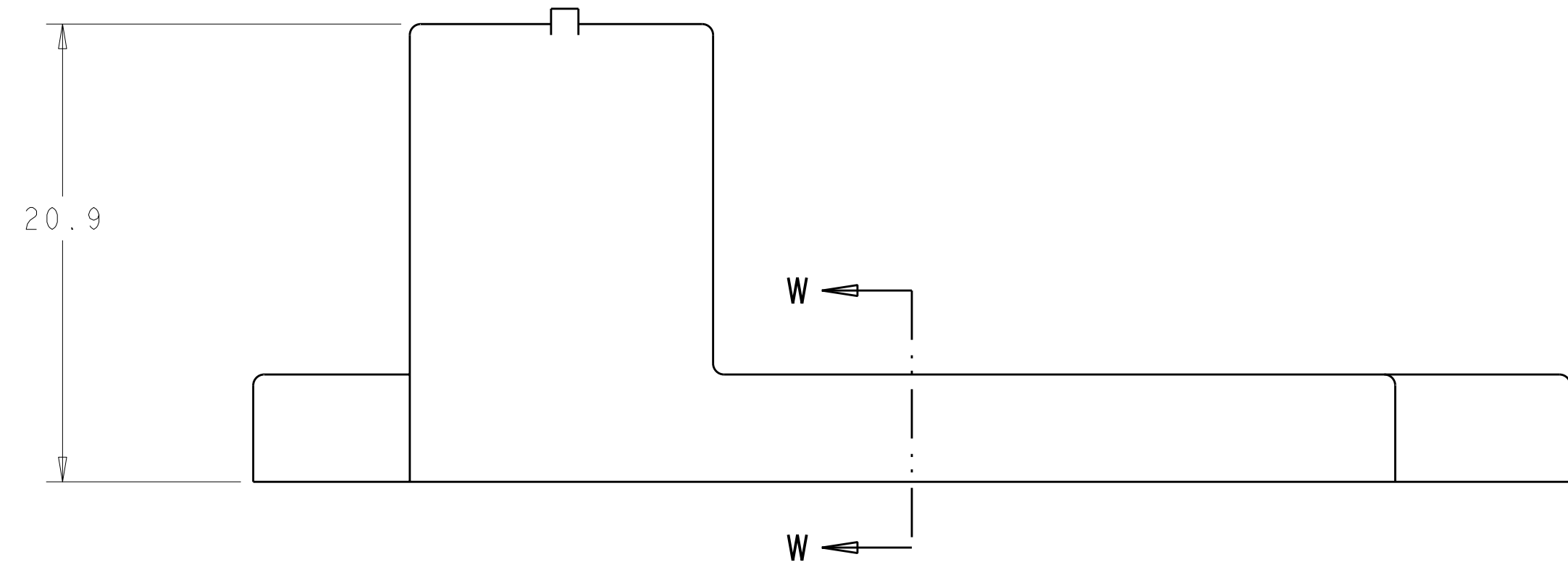

52 POSITION CONNECTOR FIXTURE
 (SHOWN WITH CLEARANCE FOR ALL KEY OPTIONS)

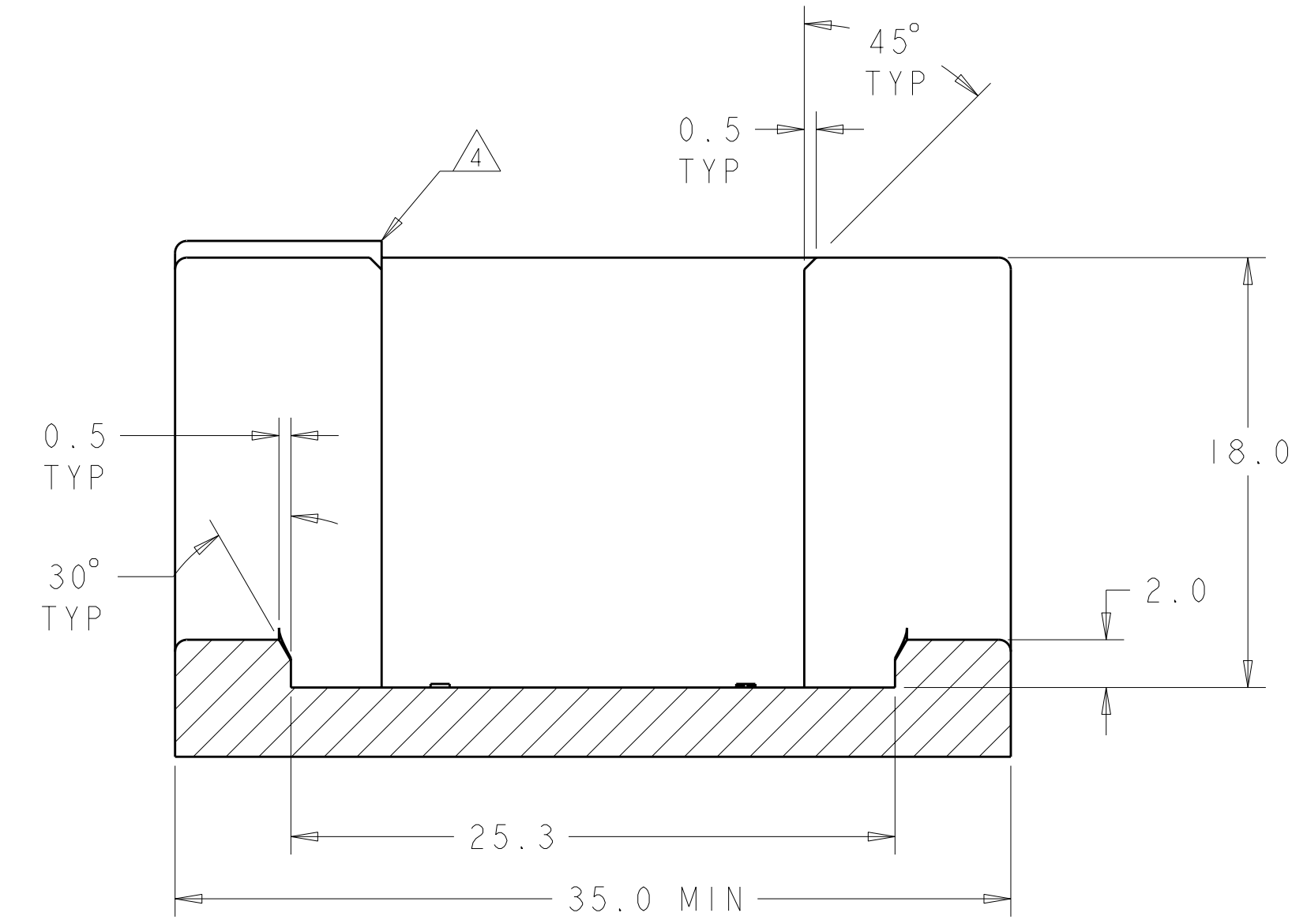

SECTION W-W

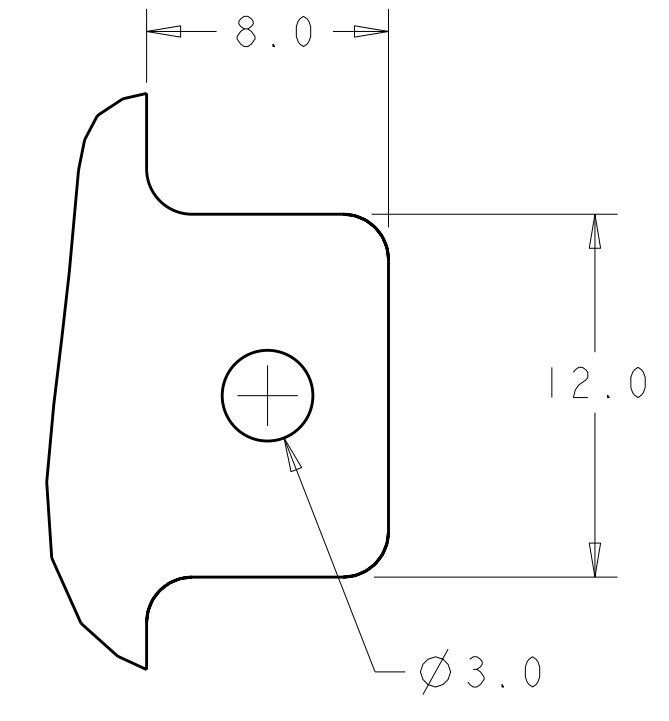

DETAIL X
 SCALE 4:1

- CONNECTOR FIXTURE SHOULD BE USED TO VERIFY THE RECEPTACLE CARRIER IS PROPERLY SEATED AND LOCKED INTO THE SHIELD ASSEMBLY. THE CONNECTOR WILL NOT FULLY MATE TO THE FIXTURE IF THE RECEPTACLE CARRIER IS OUT OF POSITION.
- RECOMMEND USING A SENSING DEVICE FOR VERIFYING FULLY MATED CONNECTORS. SUCH A DEVICE IS AT THE CUSTOMERS DISCRETION.
- RECOMMENDED MATERIAL: HARDENED STEEL.
- NO RADII OR CHAMFER PERMITTED IN SPECIFIED AREA. MUST MAINTAIN 90° EDGE.
- RADII TO BE 0.5 UNLESS OTHERWISE SPECIFIED.
- OPTIONAL CONSTRAINT FEATURE.

DIMENSIONS: mm 		TOLERANCES UNLESS OTHERWISE SPECIFIED: 9 PLC ± 1 PLC ±0.2 3 PLC ±0.05 5 PLC ± 4 PLC ± ANGLES ± FINISH ±1*		DWN: FOLTZ 24OCT2007 CHK: G. MARTIN 24OCT2007 APVD: G. MARTIN 24OCT2007 NAME: SHIELD ASSEMBLY, 52 POSITION, LEVER ASSISTED, 0.64mm GENERATION Y, CONNECTOR SIZE: A11 CAGE CODE: 00779 DRAWING NO: C=1924346 RESTRICTED TO: REV A2	
MATERIAL:		FINISH:		Tyco Electronics Harrisburg, PA 17105-3608 SCALE: 4:1 SHEET 2 OF 2	