

P	LTR	DESCRIPTION	DATE	DWN	APVD
	A	INITIAL DRAWING	30JUN2020	RV	MB

Electrical Specifications (-55°C to +105°C unless otherwise specified)

Input	
Input supply voltage range (Vcc)	4 - 32 Vdc
Input current (max.)	16mAdc
Must turn-on voltage	4Vdc
Must turn-off voltage	1Vdc
Reverse voltage protection	-32Vdc
I/O	
Dielectric strength (min.)	1,500Vrms/60 Hz.
Insulation resistance (min.) @ 500Vdc	10 ⁹ ohms
Capacitance (max.)	20pF
Output	
Output current rating (max.)	25Arms (Fig. 2, Note 1)
Surge current (max.)	80A pk (Fig. 1, Note 2)
Continuous load voltage (max.)	250Vrms
Transient blocking voltage (max.)	500V pk
Frequency range	45 - 440 Hz.
Output voltage drop (max.) @ 25A load current	1.5Vrms
Off-state leakage current (max.) @ 220Vrms/400 Hz.	10mArms
Turn-on time (max.)	1/2 cycle
Turn-off time (max.)	1 cycle
Off-state dv/dt (min.), with snubber	200V /μs (Note 3)
Zero voltage turn-on window (max.), PS10-1Y	15V pk
Zero voltage turn-on window (max.), PS10-2Y	40V pk
Waveform distortion (max.)	4Vrms
Output chip junction temperature (max.)	125°C (Note 4)
Thermal resistance (max.), junction to ambient	6.8°C/W
Thermal resistance (max.), junction to case	1.2°C/W

KILOVAC Part Number	TE Part Number	Zero Crossing Window
PS10-1Y	9-1617814-0	15 V pk max.
PS10-2Y	1617815-3	40 V pk max.

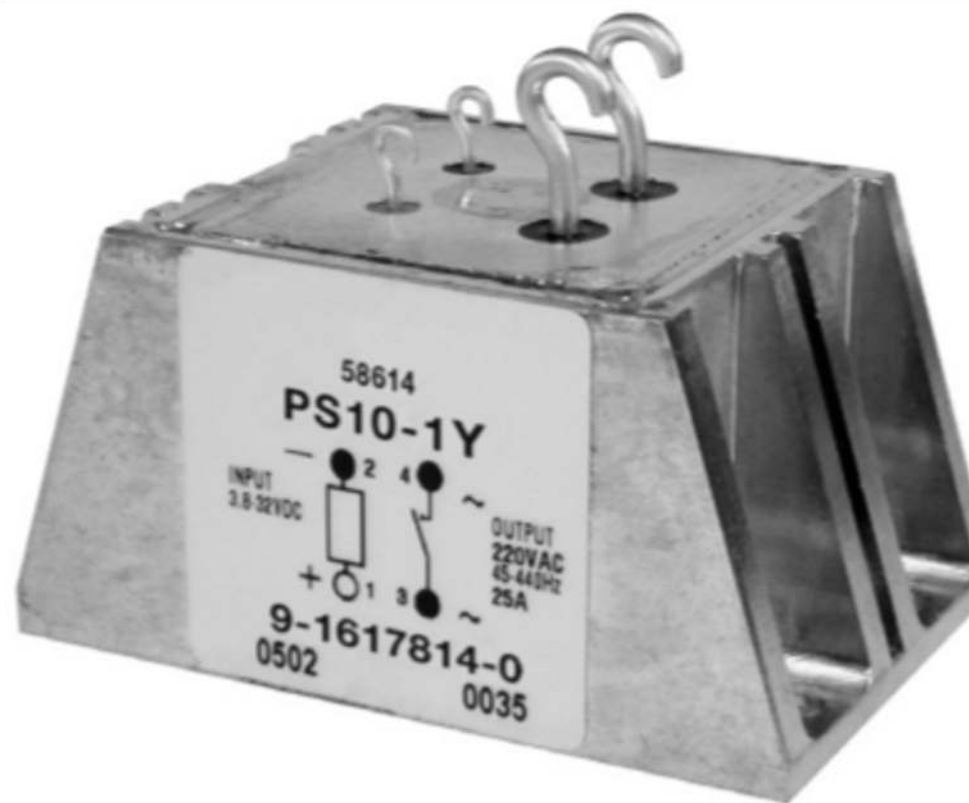

Product Facts

- Optically coupled all solid state relay
- TTL compatible input
- Zero voltage turn-on for low EMI
- Custom power package

Circuit Diagram

Terminal View

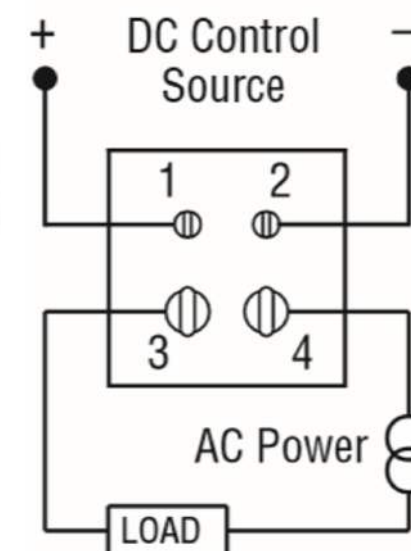

Environmental Characteristics

Ambient Temperature Range —
 Operating — -55°C to +110°C
 Storage — -55°C to +125°C

Vibration Resistance —
 30 G's, 10-3,000 Hz

Shock Resistance —
 1,500 G's, 0.5 ms pulse

Constant Acceleration Resistance (Y1 axis) —
 5,000 G's

THIS DRAWING IS A CONTROLLED DOCUMENT.		DWN RV	30JUN2020		
		CHK VR	30JUN2020		
DIMENSIONS: INCHES		APVD MB	30JUN2020	NAME	
		PRODUCT SPEC		PS10 SERIES HIGH PERFORMANCE SSR RELAYS	
		APPLICATION SPEC		-	
MATERIAL		WEIGHT	-	SIZE	A3
FINISH		-		CAGE CODE	-
		CUSTOMER DRAWING		DRAWING NO	C=PS10-SERIES
		SCALE		NTS	SHEET 1 OF 2
				REV	A

P	LTR	DESCRIPTION	DATE	DWN	APVD
-	-	SEE SHEET 1	-	-	-

Outline Drawing

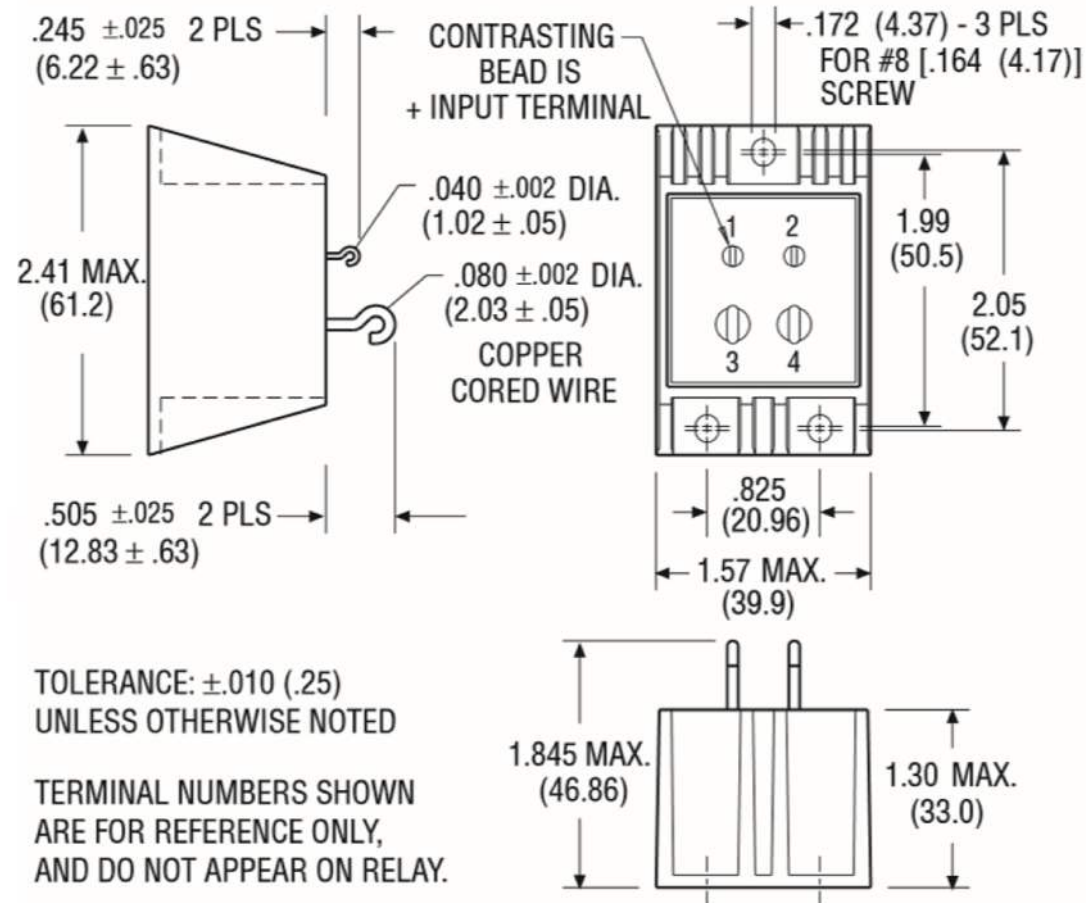

Notes

1. Operation at elevated load currents up to 25 amps is dependent on the use of suitable heatsink to maintain case temperature per Fig. 2.
2. Heating of output chips during and after a surge may cause loss of output blocking capability until junction temperature falls below maximum rating.
3. Internal snubber network is provided across output chips.
4. Case temperature measurement point is center of mounting surface.

Figure 1 - Peak Surge Current vs. Surge Current Duration

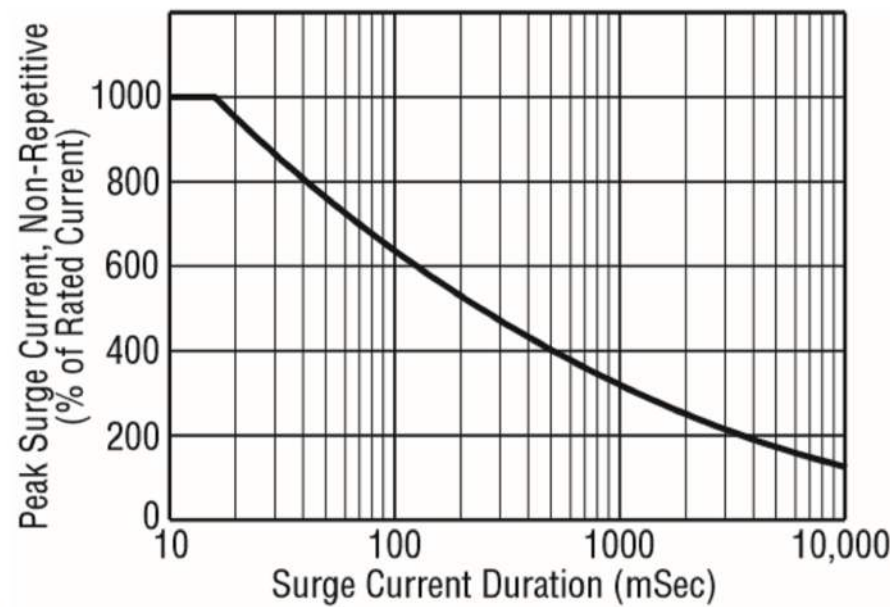
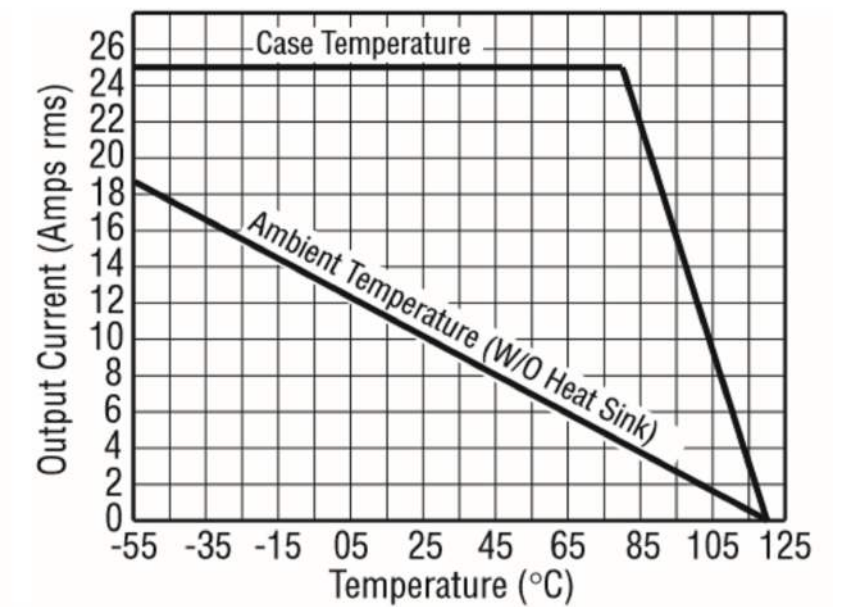

Figure 2 - Load Current vs. Temperature



ALL DIMENSIONS ARE IN INCHES(MM)

THIS DRAWING IS A CONTROLLED DOCUMENT.		DWN RV 30JUN2020			
		CHK VR 30JUN2020			
DIMENSIONS: INCHES		APVD MB 30JUN2020	NAME PS10 SERIES HIGH PERFORMANCE SSR RELAYS		
		PRODUCT SPEC -	RESTRICTED TO -		
TOLERANCES UNLESS OTHERWISE SPECIFIED:		APPLICATION SPEC -	SIZE A3	CAGE CODE -	DRAWING NO C-PS10-SERIES
0 PLC ± -		WEIGHT -	SCALE NTS SHEET 2 OF 2 REV A		
1 PLC ± -		CUSTOMER DRAWING			
2 PLC ± -					
3 PLC ± -					
4 PLC ± -					
ANGLES ± -					
MATERIAL -					
FINISH -					