

THIS DRAWING IS UNPUBLISHED. RELEASED FOR PUBLICATION
 © COPYRIGHT - By - ALL RIGHTS RESERVED.

Loc		DIST		REVISIONS			
P	LTR	DESCRIPTION		DATE	DWN	APVD	
AD	00	C1	REVISED PER ECO-14-018779	16DEC2014	NK	RH	

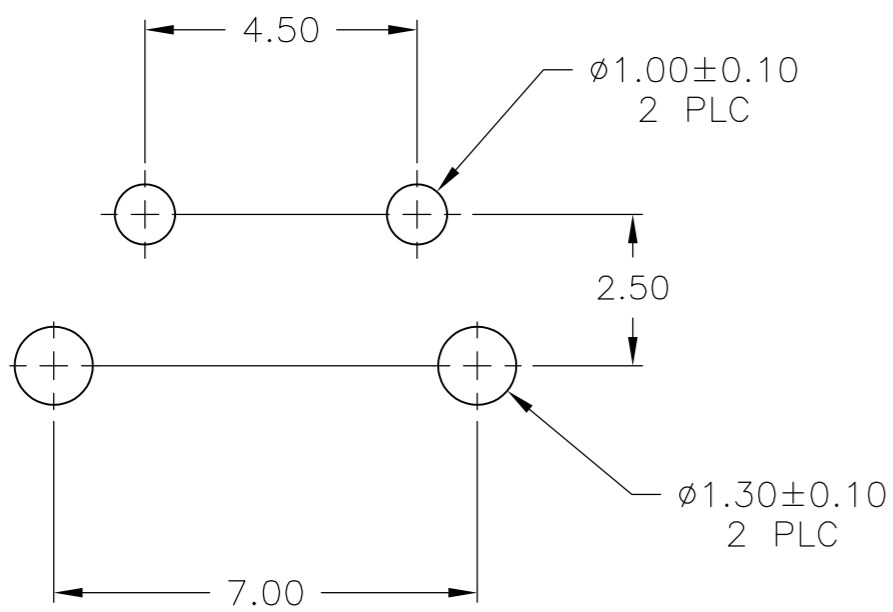
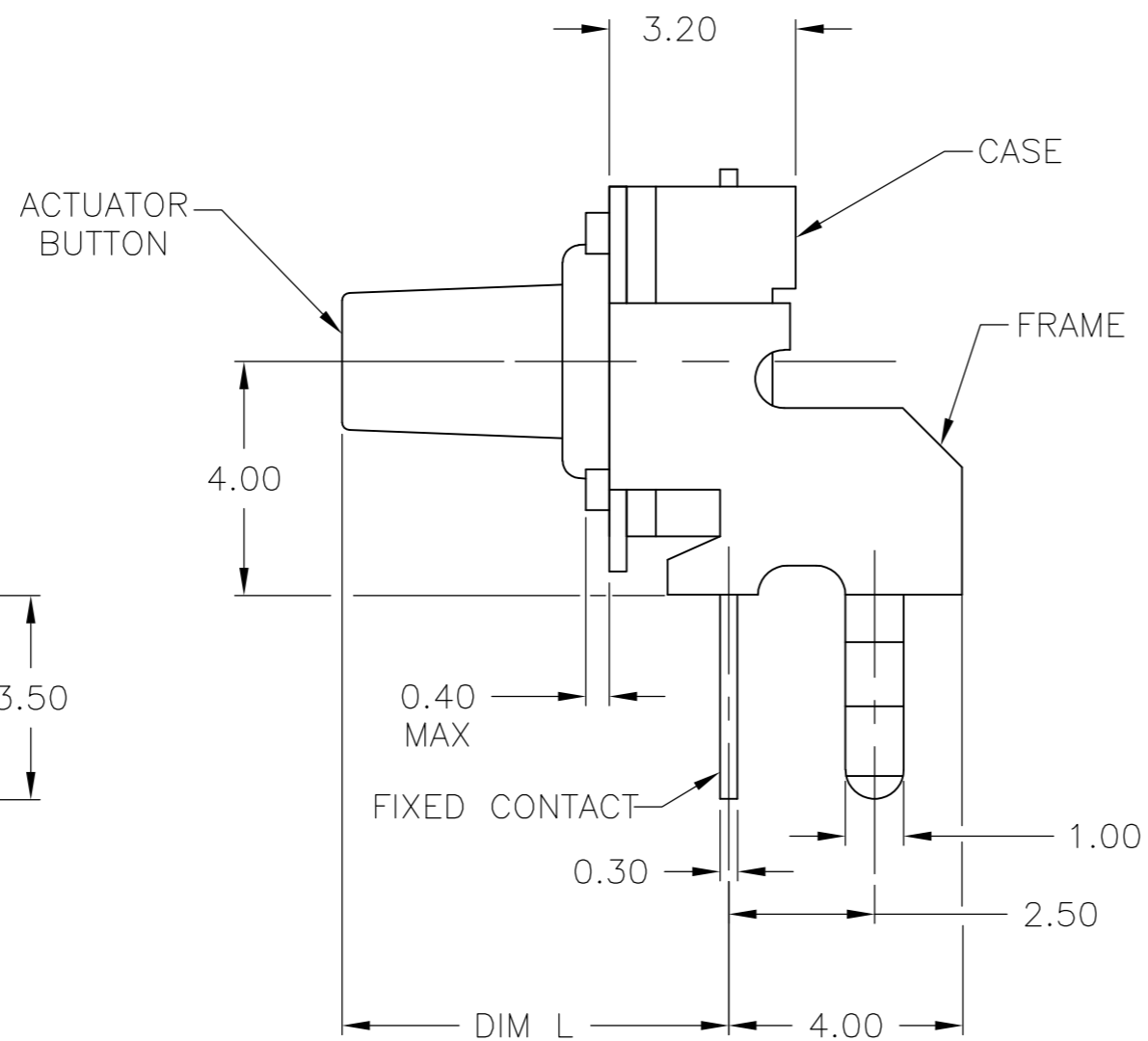
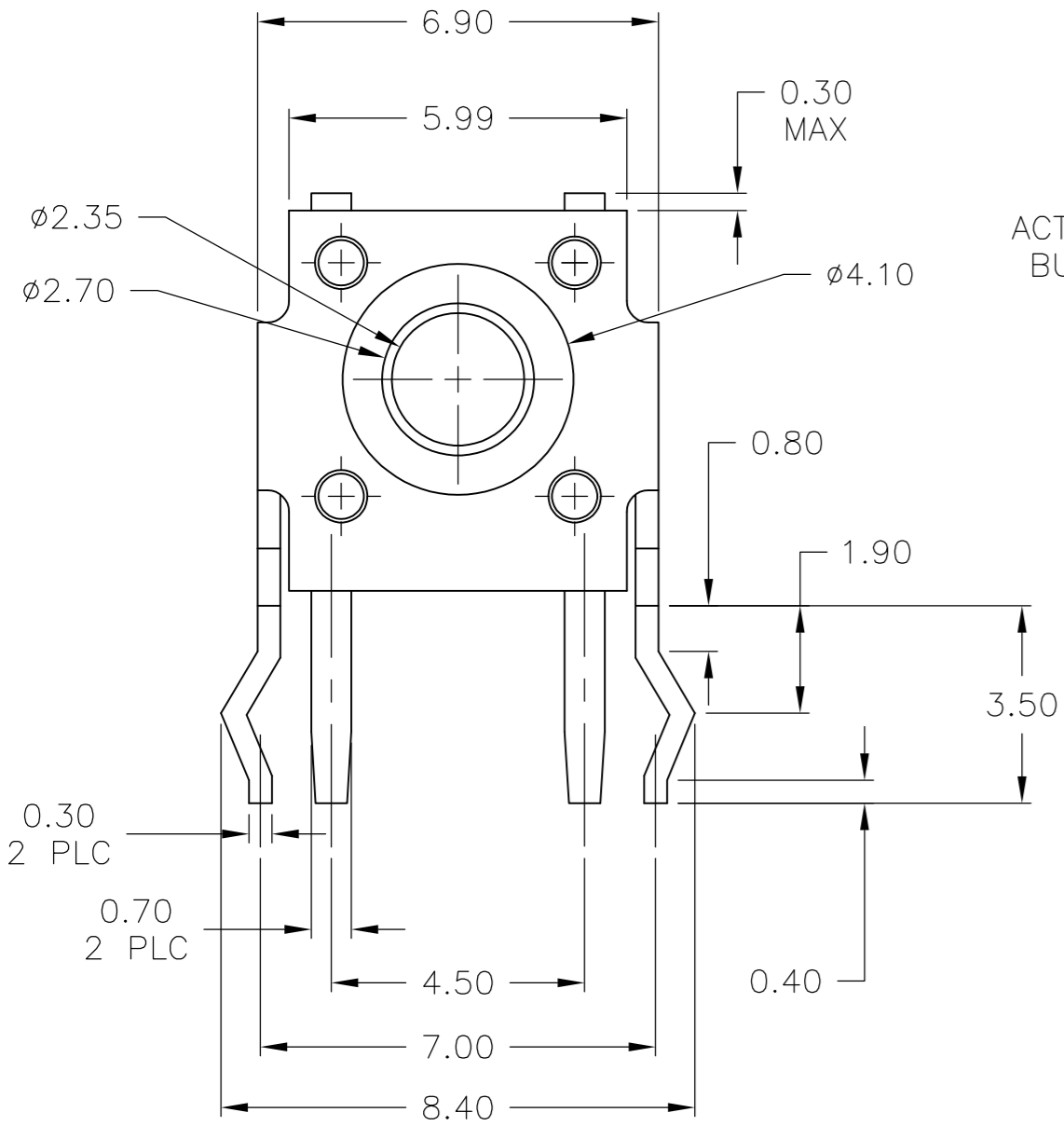
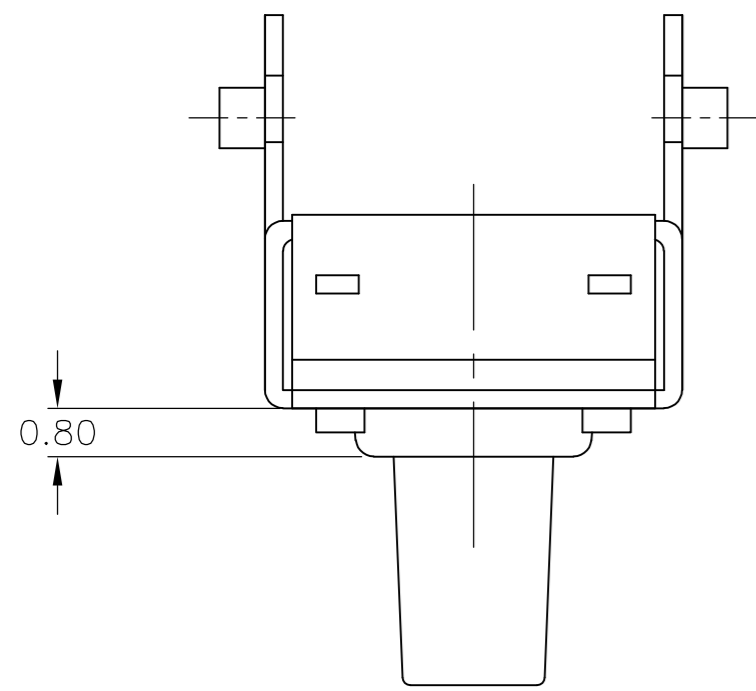

RECOMMENDED BOARD LAYOUT

SPECIFICATIONS:

MATERIALS

- CASE- PPS, UL94V-0, BLACK
- ACTUATOR- NYLON 46, UL94V-0, BLACK
- FRAME- STEEL, TIN PLATE
- SEAL- SILICON RUBBER, BLACK
- CONTACT- STAINLESS STEEL, PLATING-SILVER/NICKEL
- TERMINAL- BRASS, PLATING-SILVER/NICKEL

ELECTRICAL:

- MAX CONTACT RATING: 50MILLIAMPS@24V DC
- MIN CONTACT RATING: 10MICROAMPS@1V DC
- INITIAL CONTACT RESISTANCE- 100 MILLIOHMS MAX, PER EIA-364-23B, EACH POSITION
- INSULATION RESISTANCE- 100 MEGOHM MIN. PER EIA-364-21C EACH POSITION
- DIELECTRIC STRENGTH- 500 VAC

MECHANICAL:

- ACTUATION FORCE- SEE TABLE
- ACTUATION TRAVEL- .35 +/- .2 mm
- LIFE EXPECTANCY- 1,000,000 CYCLES MIN (2 CYCLES PER SECOND AND 150% ACTUATION FORCE), PER EIA-448 METHODS 8 AND 9
- VIBRATION- PER EIA 364-28D, CONDITION VII, LEVEL E
- MECHANICAL SHOCK- PER EIA-364-27C, CONDITION A

ENVIRONMENTAL:

- OPERATING TEMPERATURE- -35 TO +85 DEGREES C
- STORAGE TEMPERATURE- -35 TO +85 DEGREES C
- HUMIDITY AND TEMPERATURE CYCLING- PER EIA-364-31B, METHOD III
- THERMAL SHOCK- PER EIA-364-32C, -35 TO +85 DEGREES C
- SOLDERABILITY- PER EIA-364-52, CLASS 2, CATEGORY 1, TEMP, 260 DEGREES C MAX, TIME, 2.5 SECONDS MAX, 95% MINIMUM COVERAGE
- RESISTANCE TO SOLDER HEAT- PER 109-202, CONDITION B
- 1. NO CHANGE IN INITIAL ELECTRICAL AND MECHANICAL CHARACTERISTICS
- SEALING PER IP67 - CONTACT RESISTANCE 100 MILLIOHMS MAX

1 ALL MATERIAL AND FINISHES SHALL COMPLY WITH EU DIRECTIVE 2002/95/EC OF 27JAN2003 (ROHS)

BULK	160±50gf	2.35	3.85	1571610-2
BULK	160±50gf	2.35	6.85	1571610-1
PACKAGING	OPERATING FORCE	I	L	TE PART NUMBER

DIMENSIONS:		TOLERANCES UNLESS OTHERWISE SPECIFIED:		DWN		19JUN03		R BROWN	
mm		0 PLC	± -	CHK	M SARVER	19JUN03		TE Connectivity	
		1 PLC	± -	APVD	M SARVER	19JUN03		NAME	
		2 PLC	± 0.30	PRODUCT SPEC				SWITCH ASSEMBLY, TACTILE, RIGHT ANGLE, SEALED	
		3 PLC	± -	APPLICATION SPEC				SIZE	CAGE CODE
		4 PLC	± -					A2	00779
		ANGLES	± -					DRAWING NO	RESTRICTED TO
		FINISH						C=1571610	-
MATERIAL				WEIGHT	-			SCALE	SHEET
				CUSTOMER DRAWING				8:1	1 of 1
								REV	C1