

P.C.B LAYOUT

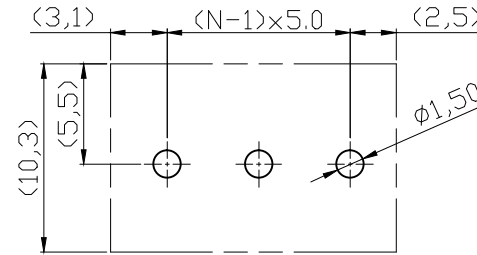

Material

Terminal body
(metal housing):Brass(CuZn)
Terminal screw: Steel Zinc plating "-" slot type
Contacts: Brass
Surface of solder tail: Tin plated
Insulator (housing): Thermoplastic (UL94V-0),Green

Electrical UL

Voltage rating: 300VAC
Current rating: 10A
Wire range:
Solid wire(AWG): 12-22
Stranded wire(AWG): 12-22
Torque(Lb-In): 3.5
Screw: M2.5
Wire strip length: 6-7mm
Withstanding Voltage: 1.6KV
Operating temperature: -40°C to +115°C
Soldering temperature: 250°C±10°C/5 Sec
Safety Approval:

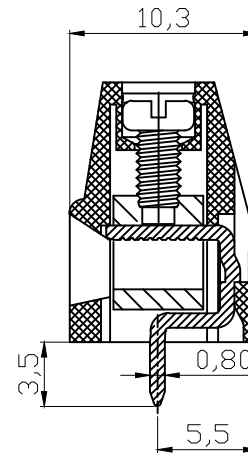
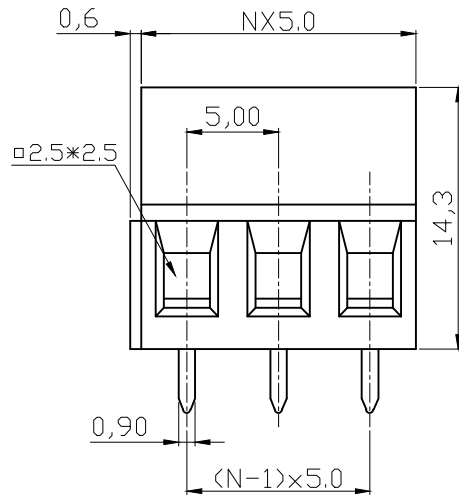

N=Number of contacts

RoHS compliant

Unit: mm



File No.: E349947

Scale	1:1				Date	Name	Customer-No.
TOLERANCE					Drawn	29.07.2009	Dean
X.	±0.50				Approved	18.04.2016	Joanna
X.X	±0.30						
X.XX	±0.10						
DIM	TOL	②	Add UL	18.04.2016	Joanna	ASSMANN WSW-No. A-TB500-TIxx	
X.°	±1°	①	Drawn	29.07.2009	Dean	Drawing-No.	ASS 3594 CO rev02
X.X°	±X°					Replace	Sheet
Angle	TOL	Id.	Modification	Date	Name		

