

CGH55030F1/P1

30 W, 5500-5800 MHz, 28V, GaN HEMT for WiMAX

Description

WolfSpeed's CGH55030F1/P1 is a gallium nitride (GaN) high electron mobility transistor (HEMT) designed specifically for high efficiency, high gain and wide bandwidth capabilities, which makes the CGH55030F1/P1 ideal for 5.5-5.8 GHz WiMAX and BWA amplifier applications. The transistor is available in both screw-down, flange and solder-down, pill packages. Based on appropriate external match adjustment, the CGH55030F1/P1 is suitable for 4.9 - 5.5 GHz applications as well.

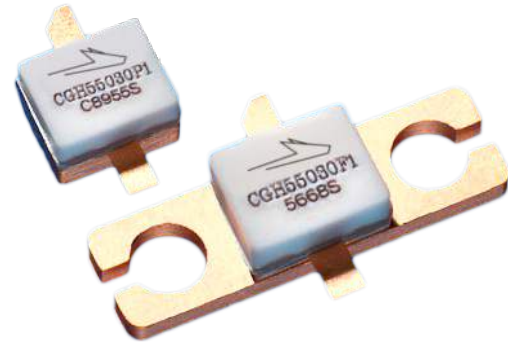

Package Types: 440196 & 440166
PN: CGH55030P1 & CGH55030F1

Typical Performance Over 5.5-5.8 GHz ($T_c = 25^\circ\text{C}$) of Demonstration Amplifier

Parameter	5.50 GHz	5.65 GHz	5.80 GHz	Units
Small Signal Gain	9.5	10.0	9.5	dB
EVM at $P_{AVE} = 29$ dBm	1.1	0.9	0.9	%
EVM at $P_{AVE} = 36$ dBm	2.2	1.4	1.4	%
Drain Efficiency at $P_{AVE} = 4$ W	23	24	25	%
Input Return Loss	10.8	22	9.3	dB

Notes:

¹ Measured in the CGH55030-AMP amplifier circuit, under 802.16 OFDM, 3.5 MHz Channel BW, 1/4 Cyclic Prefix, 64 QAM Modulated Burst, Symbol Length of 59, Coding Type RS-CC, Coding Rate Type 2/3, $P_{AR} = 9.8$ dB @ 0.01 % Probability on CCDF.

Features

- 300 MHz Instantaneous Bandwidth
- 30 W Peak Power Capability
- 10 dB Small Signal Gain
- 4 W $P_{AVE} < 2.0\%$ EVM
- 25% Efficiency at 4 W Average Power

Applications

- Designed for WiMAX Fixed Access 802.16-2004 OFDM Applications
- Designed for Multi-carrier DOCSIS Applications







Absolute Maximum Ratings (not simultaneous) at 25°C Case Temperature

Parameter	Symbol	Rating	Units	Conditions
Drain-Source Voltage	V_{DSS}	120	V	25°C
Gate-to-Source Voltage	V_{GS}	-10, +2		
Power Dissipation	P_{DISS}	14	W	
Storage Temperature	T_{STG}	-65, +150	°C	
Operating Junction Temperature	T_J	225		
Maximum Forward Gate Current	I_{GMAX}	7.0	mA	25°C
Maximum Drain Current ¹	I_{DMAX}	3		
Soldering Temperature ²	T_S	245	°C	
Screw Torque	τ	40	in-oz	
Thermal Resistance, Junction to Case ³	$R_{\theta JC}$	4.8	°C/W	85°C
Case Operating Temperature ³	T_C	-40, +150	°C	30 seconds

Notes:

¹ Current limit for long term, reliable operation

² Refer to the Application Note on soldering at wolfspeed.com/rf/document-library

³ Measured for the CGH55030F1 at $P_{DISS} = 14$ W

Electrical Characteristics ($T_C = 25^\circ\text{C}$)

Characteristics	Symbol	Min.	Typ.	Max.	Units	Conditions
DC Characteristics¹						
Gate Threshold Voltage	$V_{GS(th)}$	-3.8	-3.0	-2.3	V_{DC}	$V_{DS} = 10$ V, $I_D = 7.2$ mA
Gate Quiescent Voltage	$V_{GS(Q)}$	—	-2.7	—		$V_{DS} = 28$ V, $I_D = 250$ mA
Saturated Drain Current	I_{DS}	5.8	7.0	—	A	$V_{DS} = 6.0$ V, $V_{GS} = 2$ V
Drain-Source Breakdown Voltage	V_{BR}	84	—	—	V_{DC}	$V_{GS} = -8$ V, $I_D = 7.2$ mA
RF Characteristics² ($T_C = 25^\circ\text{C}$, $F_0 = 5.65$ GHz unless otherwise noted)						
Small Signal Gain	G_{SS}	8.5	10.0	—	dB	$V_{DD} = 28$ V, $I_{DQ} = 250$ mA
Drain Efficiency ⁴	η	19	24	—	%	$V_{DD} = 28$ V, $I_{DQ} = 250$ mA, $P_{AVE} = 4$ W
Error Vector Magnitude	EVM	—	2.0	2.5		
Output Mismatch Stress	VSWR	—	—	10 : 1	Ψ	No damage at all phase angles, $V_{DD} = 28$ V, $I_{DQ} = 250$ mA, $P_{AVE} = 4$ W
Dynamic Characteristics						
Input Capacitance	C_{GS}	—	9.0	—	pF	$V_{DS} = 28$ V, $V_{GS} = -8$ V, $f = 1$ MHz
Output Capacitance	C_{DS}	—	2.6	—		
Feedback Capacitance	C_{GD}	—	0.4	—		

Notes:

¹ Measured on wafer prior to packaging.

² Measured in the CGH55030-AMP test fixture.

³ Under 802.16 OFDM, 3.5 MHz Channel BW, 1/4 Cyclic Prefix, 64 QAM Modulated Burst, 5ms Burst, Symbol Length of 59, Coding Type RS-CC, Coding Rate Type 2/3, PAR = 9.8 dB @ 0.01 % Probability on CCDF

⁴ Drain Efficiency = P_{OUT}/P_{DC}



Typical WiMAX Performance

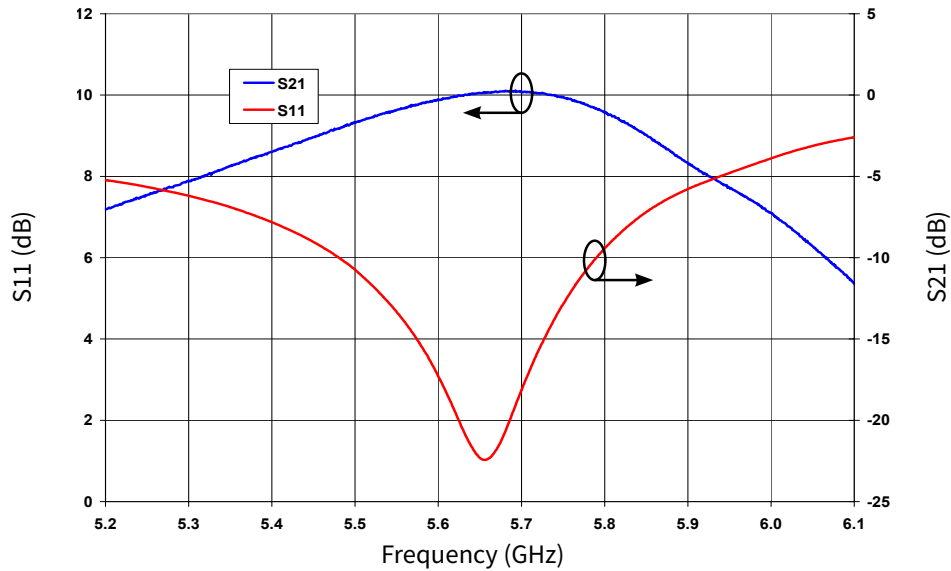

Figure 1. Small Signal S-Parameters vs Frequency of CGH55030F1 and CGH55030P1 in the CGH55030-AMP
 $V_{DD} = 28\text{ V}, I_{DQ} = 250\text{ mA}$

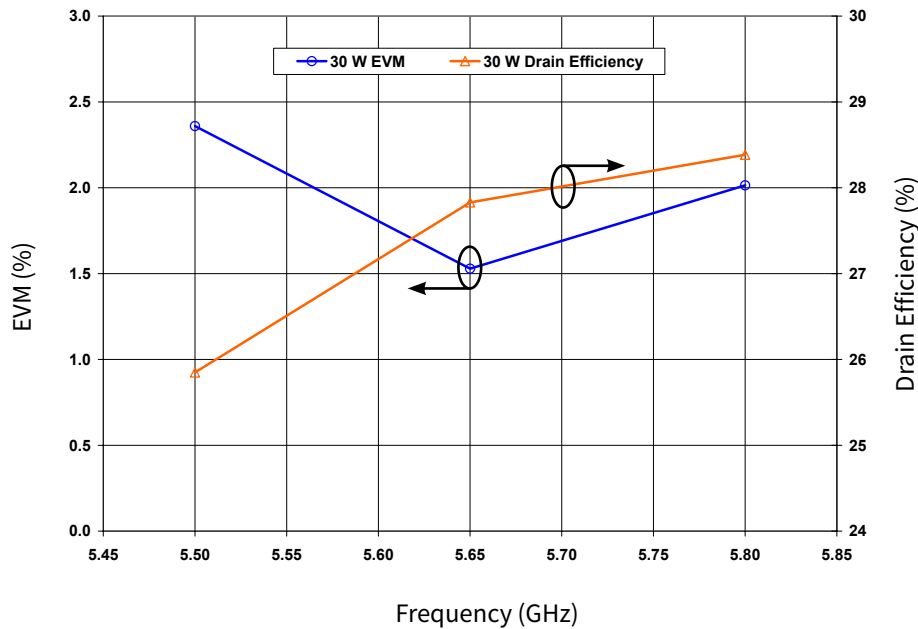

Figure 2. Typical EVM and Efficiency vs Frequency of CGH55030F1 and CGH55030P1 in the CGH55030-AMP
 $V_{DD} = 28\text{ V}, I_{DQ} = 250\text{ mA}, 802.16\text{-}2004\text{ OFDM}, PAR = 9.8\text{ dB}, P_{AVE} = 5\text{ W}$

Notes:
 Under 802.16 OFDM, 3.5 MHz Channel BW, 1/4 Cyclic Prefix, 64 QAM Modulated Burst, Symbol Length of 59, Coding Type RS-CC, Coding Rate Type 2/3, $P_{AR} = 9.8\text{ dB}$
 @ 0.01 % Probability on CCDF



Typical WiMAX Performance

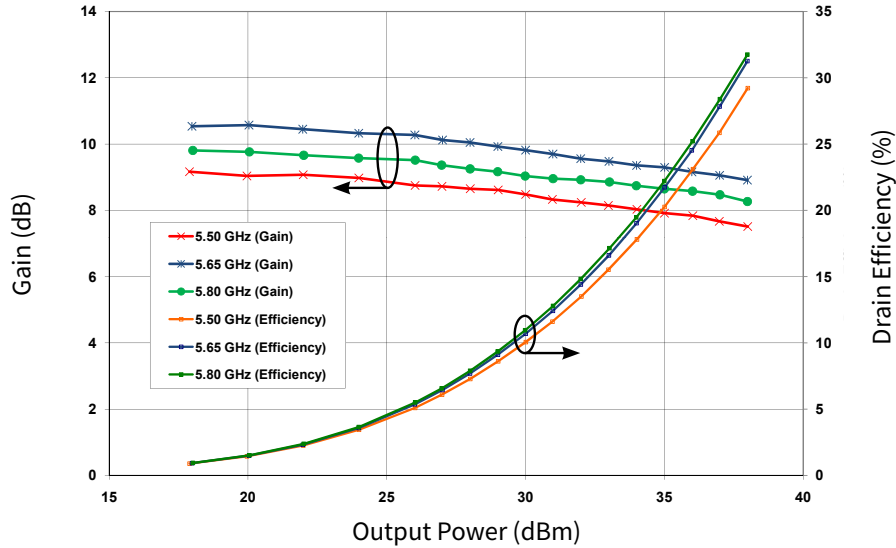

Figure 3. Drain Efficiency and Gain vs Output Power of CGH55030F1 and CGH55030P1 in CGH55030-AMP
 $V_{DD} = 28\text{ V}$, $I_{DQ} = 250\text{ mA}$, 802.16-2004 OFDM, PAR = 9.8 dB

Notes:
 Under 802.16 OFDM, 3.5 MHz Channel BW, 1/4 Cyclic Prefix, 64 QAM Modulated Burst, Symbol Length of 59, Coding Type RS-CC, Coding Rate Type 2/3, $P_{AR} = 9.8\text{ dB}$ @ 0.01 % Probability on CCDF

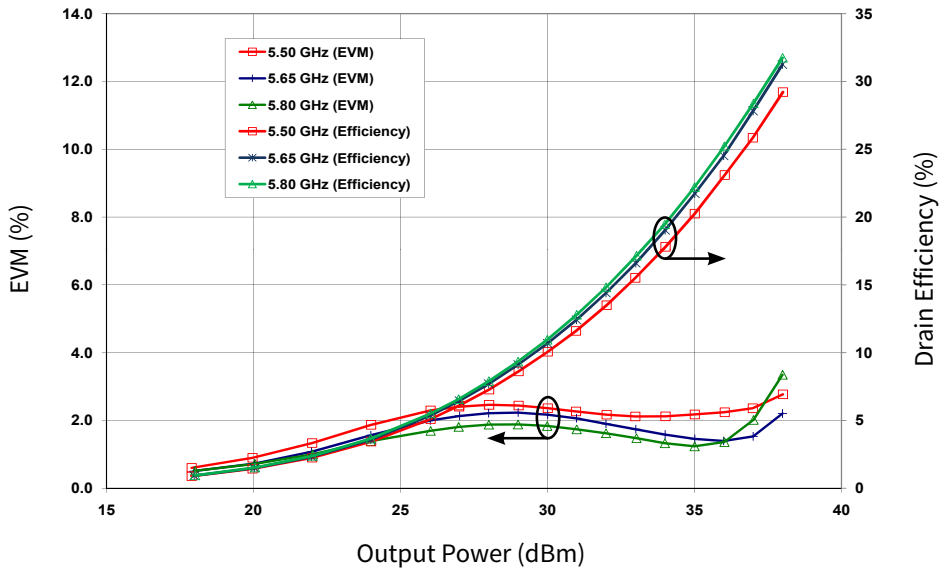

Figure 4. Typical EVM and Drain Efficiency vs Output Power of CGH55030F1 and CGH55030P1 in CGH55030-AMP at 5.50GHz, 5.65 GHz, 5.80GHz, 802.16-2004 OFDM, PAR = 9.8 dB

Notes:
 Under 802.16 OFDM, 3.5 MHz Channel BW, 1/4 Cyclic Prefix, 64 QAM Modulated Burst, Symbol Length of 59, Coding Type RS-CC, Coding Rate Type 2/3, $P_{AR} = 9.8\text{ dB}$ @ 0.01 % Probability on CCDF.



Typical DOCSIS Performance

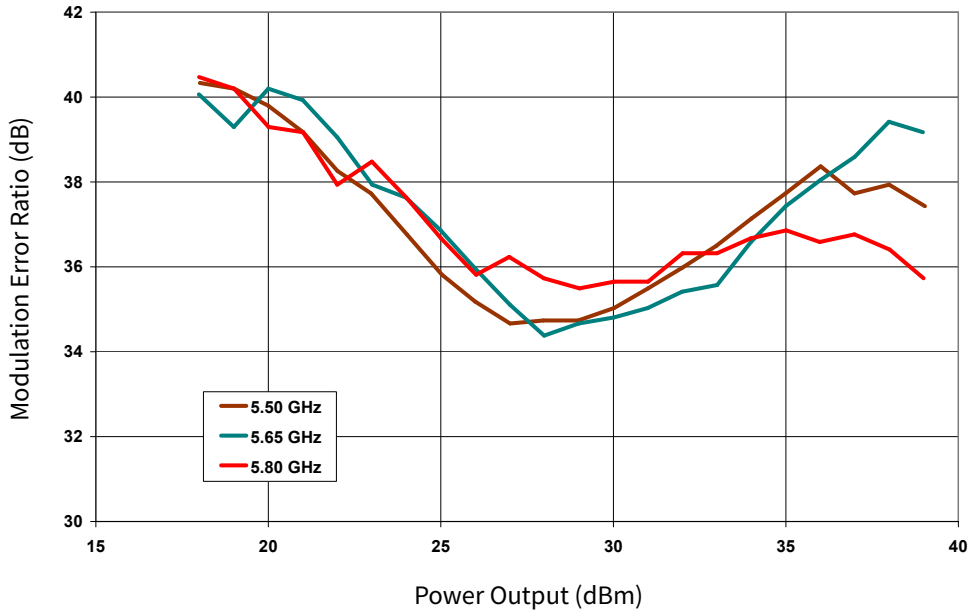

Figure 5. Modulation Error Ratio vs Output Power of CGH55030F1 and CGH55030P1 in Broadband Amplifier Circuit

Note:

MER is the metric of choice for cable systems and can be related to EVM by the following equation: $EVM(\%) = 100 \times 10^{-((MER_{dB} + MTAdB)/20)}$. MTA is the “maximum-to-average constellation power ratio” which varies with the modulation type: MTA = 0 for BPSK and QPSK; 2.55 for 16QAM and 8QAM-DS; 3.68 for 64QAM and 32QAM-DS; 4.23 for 256QAM and 128QAM-DS

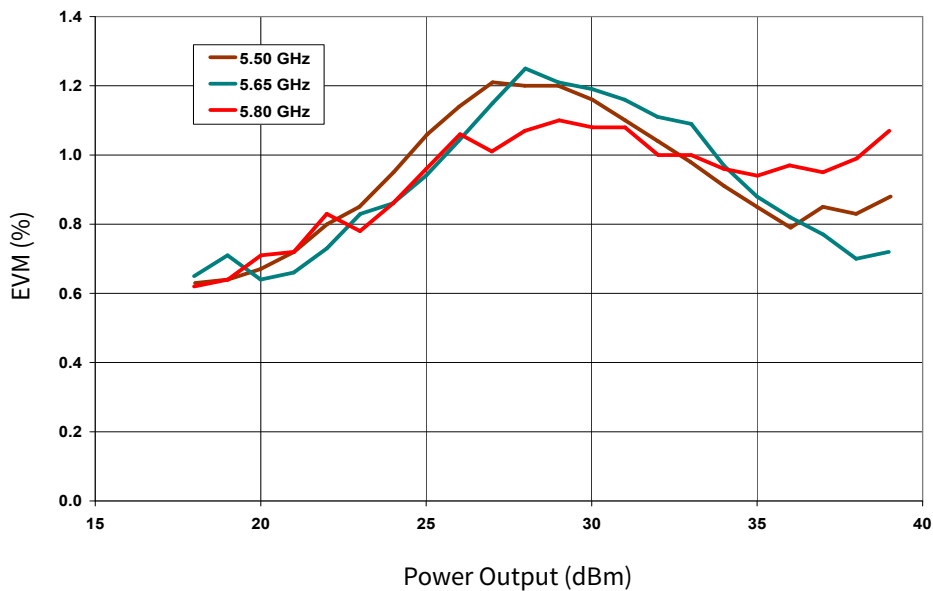

Figure 6. EVM vs Output Power of CGH55030F1 and CGH55030P1 in Broadband Amplifier Circuit

Note:

Under DOCSIS, 6.0 MHz Channel BW, 64 QAM, PN23, Filter Alpha 0.18, PAR = 6.7dB



Typical Performance

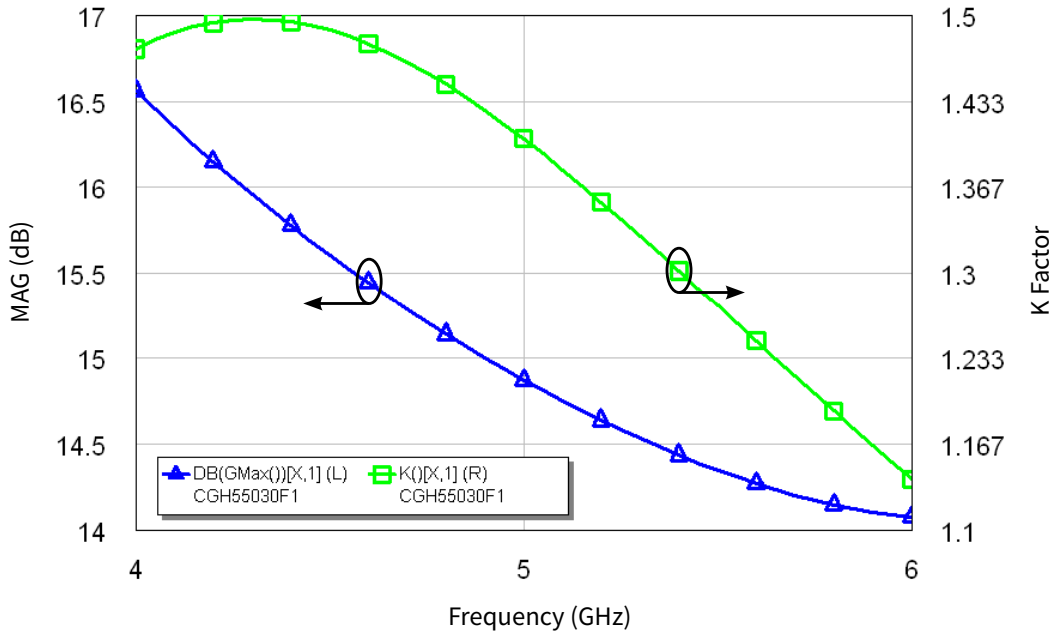

Figure 7. Simulated Maximum Available Gain and K Factor of the CGH55030F1 and CGH55030P1
 $V_{DD} = 28\text{ V}$, $I_{DQ} = 250\text{ A}$

Typical Noise Performance

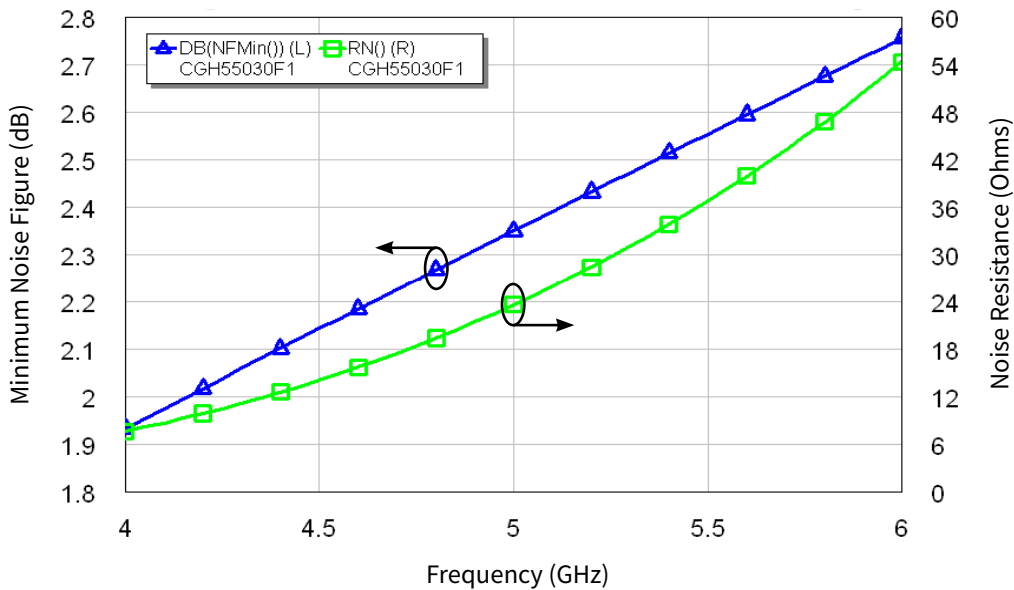
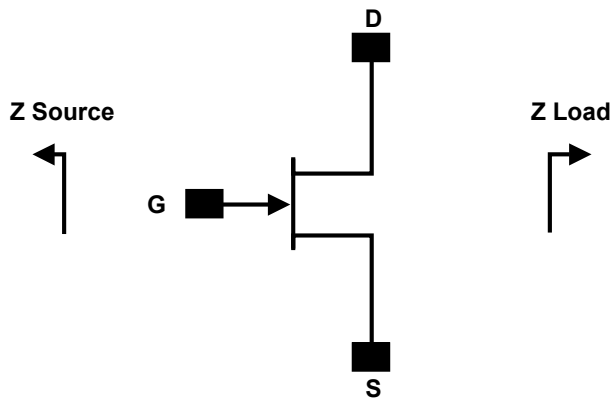

Figure 8. Simulated Minimum Noise Figure and Noise Resistance vs Frequency of the CGH55030F1 and CGH55030P1
 $V_{DD} = 28\text{ V}$, $I_{DQ} = 250\text{ mA}$



Source and Load Impedances



Frequency (MHz)	Z Source	Z Load
5500	8.0 – j12.4	14.1 – j12.6
5650	8.7 – j13.1	14.7 – j11.7
5800	8.4 – j14.0	15.4 – j11.0

Notes:

¹ $V_{DD} = 28\text{ V}$, $I_{DQ} = 250\text{ mA}$ in the 440166 package

² Impedances are extracted from CGH55030-AMP demonstration amplifier circuit and are not source and load pull data derived from the transistor

Electrostatic Discharge (ESD) Classifications

Parameter	Symbol	Class	Classification Level	Test Methodology
Human Body Model	HBM	1A	ANSI/ESDA/JEDEC JS-001 Table 3	JEDEC JESD22 A114-D
Charge Device Model	CDM	C3	ANSI/ESDA/JEDEC JS-002 Table 3	JEDEC JESD22 C101-C



CGH55030-AMP Demonstration Amplifier Circuit Bill of Materials

Designator	Description	Qty
R1	RES, 1/16W, 0603, 1%, 562 OHMS	1
R2	RES, 1/16W, 0603, 1%, 22.6 OHMS	1
C2	CAP, 0.3pF, +/-0.05pF, 0402, ATC600L	1
C16	CAP, 33 μ F, 20%, G CASE	1
C15	CAP, 1.0 μ F, 100V, 10%, X7R, 1210	1
C8	CAP 10 μ F, 16V TANTALUM	1
C9	CAP, 0.4pF, +/-0.05pF, 0603, ATC600S	1
C1	CAP, 1.2pF, +/-0.1pF, 0603, ATC600S	1
C6, C13	CAP, 200pF, 0603 PKG, 100 V	2
C4, C11	CAP, 10.0pF, +/-5%, 0603, ATC600S	2
C5, C12	CAP, 39pF, +/-5%, 0603, ATC600S	2
C7, C14	CAP, 330000pF, 0805, 100V, TEMP STABILIZ	2
J3, J4	CONN, SMA, PANEL MOUNT JACK, FLANGE	2
J1	HEADER RT>PLZ .1CEN LK 5POS	1
—	PCB, RO4350B, Er = 3.48, h = 20 mil	1
—	CGH55030	1

CGH55030-AMP Demonstration Amplifier Circuit

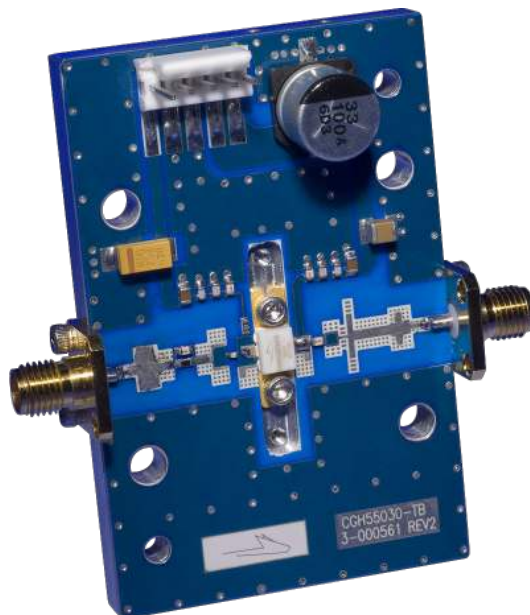



CGH55030-AMP Demonstration Amplifier Circuit Schematic

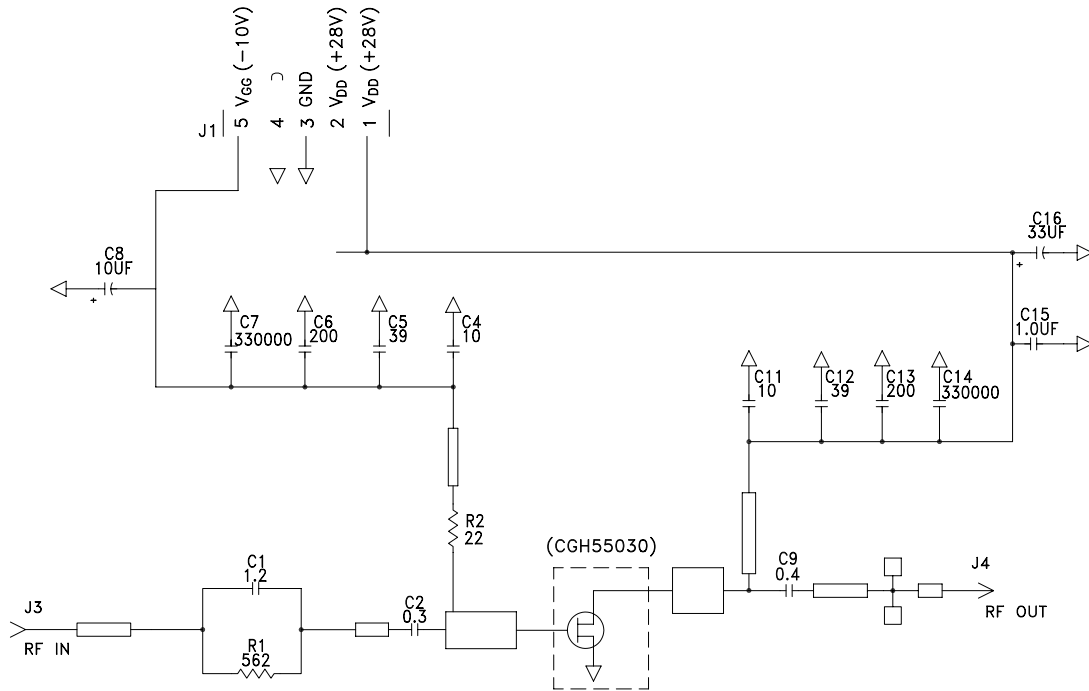

CGH55030-AMP Demonstration Amplifier Circuit Outline

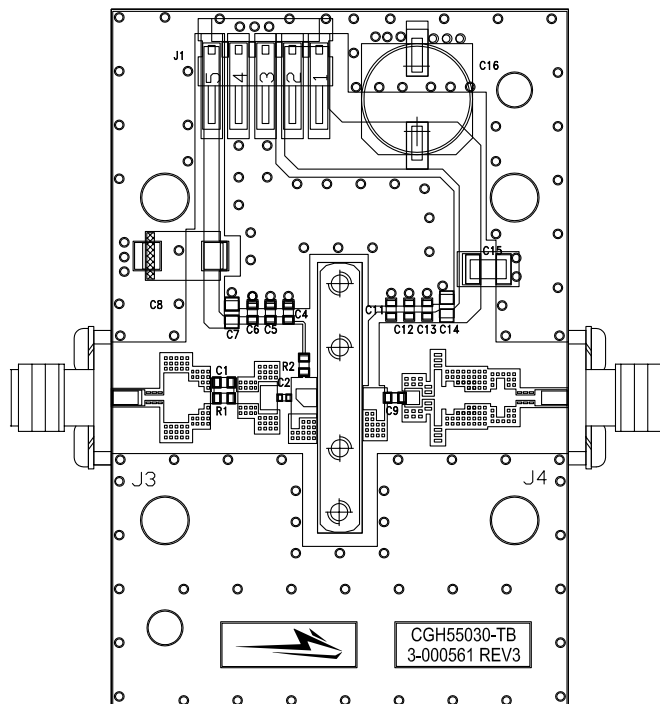



Typical Package S-Parameters for CGH55030F1 and CGH55030P1
 (Small Signal, $V_{DS} = 28\text{ V}$, $I_{DQ} = 250\text{ mA}$, angle in degrees)

Frequency	Mag S11	Ang S11	Mag S21	Ang S21	Mag S12	Ang S12	Mag S22	Ang S22
500 MHz	0.917	-157.22	12.62	91.45	0.018	7.56	0.458	-158.97
600 MHz	0.916	-161.92	10.57	87.33	0.018	4.70	0.465	-160.93
700 MHz	0.916	-165.46	9.07	83.78	0.018	2.41	0.472	-162.19
800 MHz	0.916	-168.28	7.94	80.58	0.018	0.51	0.478	-163.04
900 MHz	0.916	-170.61	7.05	77.64	0.017	-1.12	0.485	-163.64
1.0 GHz	0.916	-172.60	6.33	74.88	0.017	-2.55	0.493	-164.09
1.2 GHz	0.917	-175.88	5.24	69.73	0.017	-4.94	0.508	-164.77
1.4 GHz	0.918	-178.57	4.46	64.94	0.017	-6.84	0.525	-165.36
1.6 GHz	0.919	179.09	3.87	60.41	0.016	-8.31	0.542	-165.99
1.8 GHz	0.921	176.98	3.40	56.07	0.016	-9.39	0.559	-166.73
2.0 GHz	0.922	175.03	3.03	51.90	0.015	-10.06	0.577	-167.59
2.2 GHz	0.924	173.17	2.73	47.87	0.014	-10.31	0.594	-168.57
2.4 GHz	0.925	171.39	2.47	43.97	0.014	-10.12	0.610	-169.67
2.6 GHz	0.926	169.65	2.26	40.19	0.013	-9.46	0.626	-170.88
2.8 GHz	0.928	167.93	2.08	36.52	0.013	-8.31	0.642	-172.17
3.0 GHz	0.929	166.24	1.92	32.94	0.013	-6.65	0.656	-173.55
3.2 GHz	0.930	164.54	1.78	29.45	0.012	-4.49	0.670	-175.00
3.4 GHz	0.931	162.85	1.66	26.05	0.012	-1.85	0.683	-176.50
3.6 GHz	0.932	161.14	1.55	22.72	0.012	1.19	0.695	-178.06
3.8 GHz	0.933	159.42	1.46	19.46	0.012	4.55	0.706	-179.66
4.0 GHz	0.933	157.68	1.38	16.27	0.012	8.08	0.716	178.70
4.1 GHz	0.934	156.80	1.34	14.69	0.012	9.87	0.721	177.86
4.2 GHz	0.934	155.91	1.31	13.12	0.012	11.64	0.726	177.02
4.3 GHz	0.934	155.01	1.27	11.57	0.012	13.38	0.730	176.17
4.4 GHz	0.934	154.11	1.24	10.03	0.013	15.08	0.735	175.30
4.5 GHz	0.935	153.20	1.21	8.49	0.013	16.71	0.739	174.44
4.6 GHz	0.935	152.28	1.18	6.97	0.013	18.26	0.743	173.56
4.7 GHz	0.935	151.35	1.16	5.46	0.013	19.72	0.746	172.67
4.8 GHz	0.935	150.41	1.13	3.95	0.014	21.09	0.750	171.78
4.9 GHz	0.935	149.46	1.11	2.46	0.014	22.35	0.753	170.88
5.0 GHz	0.935	148.49	1.08	0.96	0.015	23.50	0.756	169.97
5.1 GHz	0.935	147.52	1.06	-0.52	0.015	24.55	0.760	169.05
5.2 GHz	0.935	146.53	1.04	-2.00	0.016	25.48	0.762	168.12
5.3 GHz	0.935	145.53	1.02	-3.48	0.016	26.30	0.765	167.18
5.4 GHz	0.935	144.52	1.00	-4.96	0.017	27.02	0.768	166.24
5.5 GHz	0.935	143.49	0.99	-6.43	0.018	27.62	0.770	165.28
5.6 GHz	0.935	142.45	0.97	-7.90	0.018	28.12	0.773	164.32
5.7 GHz	0.934	141.39	0.95	-9.37	0.019	28.53	0.775	163.35
5.8 GHz	0.934	140.31	0.94	-10.84	0.020	28.83	0.777	162.36
5.9 GHz	0.934	139.22	0.93	-12.32	0.020	29.05	0.779	161.37
6.0 GHz	0.934	138.12	0.91	-13.79	0.021	29.18	0.781	160.36

To download the s-parameters in s2p format, go to the [CGH55030F1/P1 Product page](#) and click on the documentation tab.



Product Dimensions CGH55030F1 (Package Type — 440166)

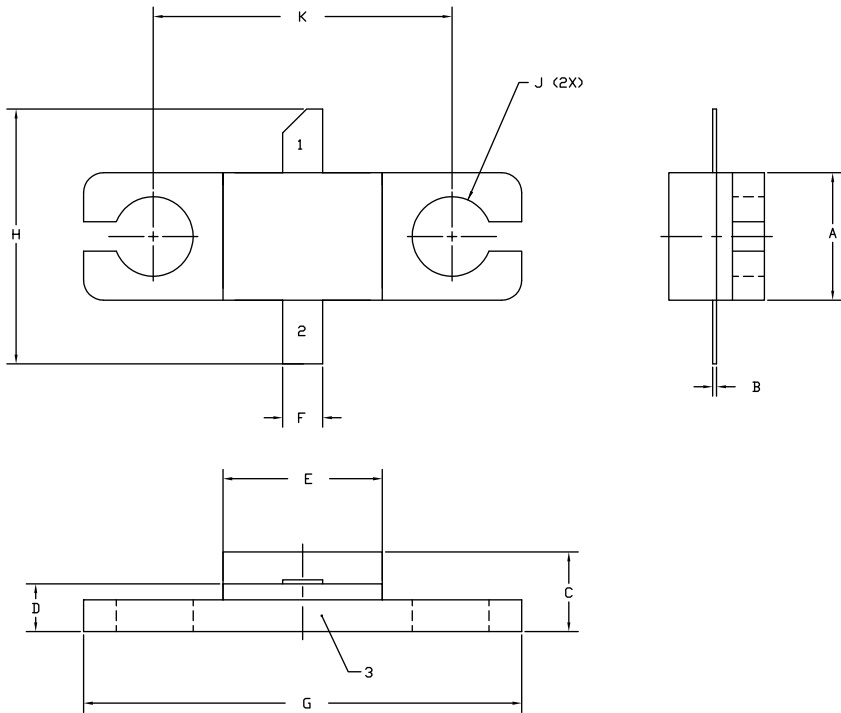

- NOTES:
1. DIMENSIONING AND TOLERANCING PER ANSI Y14.5M, 1982.
 2. CONTROLLING DIMENSION: INCH.
 3. ADHESIVE FROM LID MAY EXTEND A MAXIMUM OF 0.020" BEYOND EDGE OF LID.
 4. LID MAY BE MISALIGNED TO THE BODY OF THE PACKAGE BY A MAXIMUM OF 0.008" IN ANY DIRECTION.
 5. ALL PLATED SURFACES ARE NI/AU

DIM	INCHES		MILLIMETERS	
	MIN	MAX	MIN	MAX
A	0.155	0.165	3.94	4.19
B	0.004	0.006	0.10	0.15
C	0.115	0.135	2.92	3.43
D	0.057	0.067	1.45	1.70
E	0.195	0.205	4.95	5.21
F	0.045	0.055	1.14	1.40
G	0.545	0.555	13.84	14.09
H	0.280	0.360	7.11	9.14
J	Ø .100		2.54	
K	0.375		9.53	

PIN 1. GATE
 PIN 2. DRAIN
 PIN 3. SOURCE

Product Dimensions CGH55030P1 (Package Type — 440196)

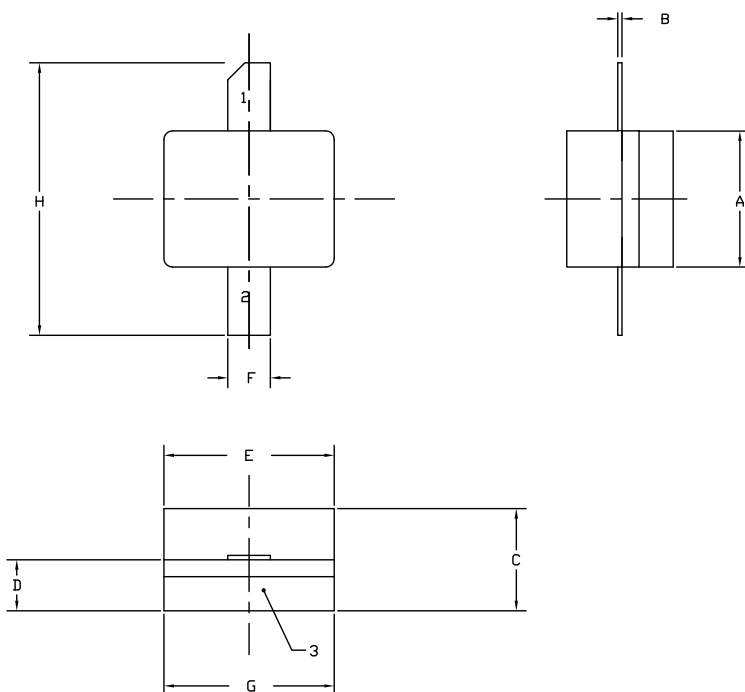

- NOTES:
1. DIMENSIONING AND TOLERANCING PER ANSI Y14.5M, 1982.
 2. CONTROLLING DIMENSION: INCH.
 3. ADHESIVE FROM LID MAY EXTEND A MAXIMUM OF 0.020" BEYOND EDGE OF LID.
 4. LID MAY BE MISALIGNED TO THE BODY OF THE PACKAGE BY A MAXIMUM OF 0.008" IN ANY DIRECTION.
 5. ALL PLATED SURFACES ARE NI/AU

DIM	INCHES		MILLIMETERS	
	MIN	MAX	MIN	MAX
A	0.155	0.165	3.94	4.19
B	0.003	0.006	0.10	0.15
C	0.115	0.135	2.92	3.17
D	0.057	0.067	1.45	1.70
E	0.195	0.205	4.95	5.21
F	0.045	0.055	1.14	1.40
G	0.195	0.205	4.95	5.21
H	0.280	0.360	7.11	9.14

PIN 1. GATE
 PIN 2. DRAIN
 PIN 3. SOURCE

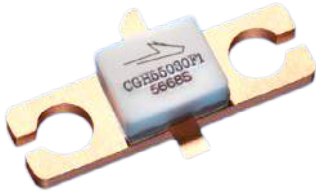
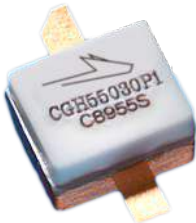
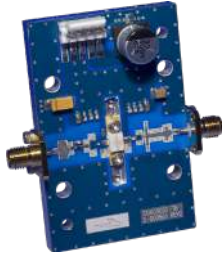

Product Ordering Information

Order Number	Description	Unit of Measure	Image
CGH55030F1	GaN HEMT	Each	
CGH55030P1	GaN HEMT	Each	
CGH55030F1-AMP	Test board with GaN HEMT installed	Each	

**For more information, please contact:**

4600 Silicon Drive
Durham, NC 27703 USA
Tel: +1.919.313.5300
www.wolfspeed.com/RF

Sales Contact
RFSales@wolfspeed.com

RF Product Marketing Contact
RFMarketing@wolfspeed.com

Notes & Disclaimer

Specifications are subject to change without notice. “Typical” parameters are the average values expected by Wolfspeed in large quantities and are provided for information purposes only. Wolfspeed products are not warranted or authorized for use as critical components in medical, life-saving, or life-sustaining applications, or other applications where a failure would reasonably be expected to cause severe personal injury or death. No responsibility is assumed by Wolfspeed for any infringement of patents or other rights of third parties which may result from use of the information contained herein. No license is granted by implication or otherwise under any patent or patent rights of Wolfspeed.

© 2015-2022 Wolfspeed, Inc. All rights reserved. Wolfspeed® and the Wolfstreak logo are registered trademarks and the Wolfspeed logo is a trademark of Wolfspeed, Inc.
PATENT: <https://www.wolfspeed.com/legal/patents>

The information in this document is subject to change without notice.