

THIS DRAWING IS UNPUBLISHED. RELEASED FOR PUBLICATION, 19  
 © COPYRIGHT 19 BY AMP INCORPORATED. ALL INTERNATIONAL RIGHTS RESERVED.

LOC	DIST	P	F	ZONE	LTR	REVISIONS	DATE	APPD
AF	50				C	REDRAWN PER 0710-0004-96	23/JAN/96	PF/GY

1 CONTINUOUS STRIP ON REEL.

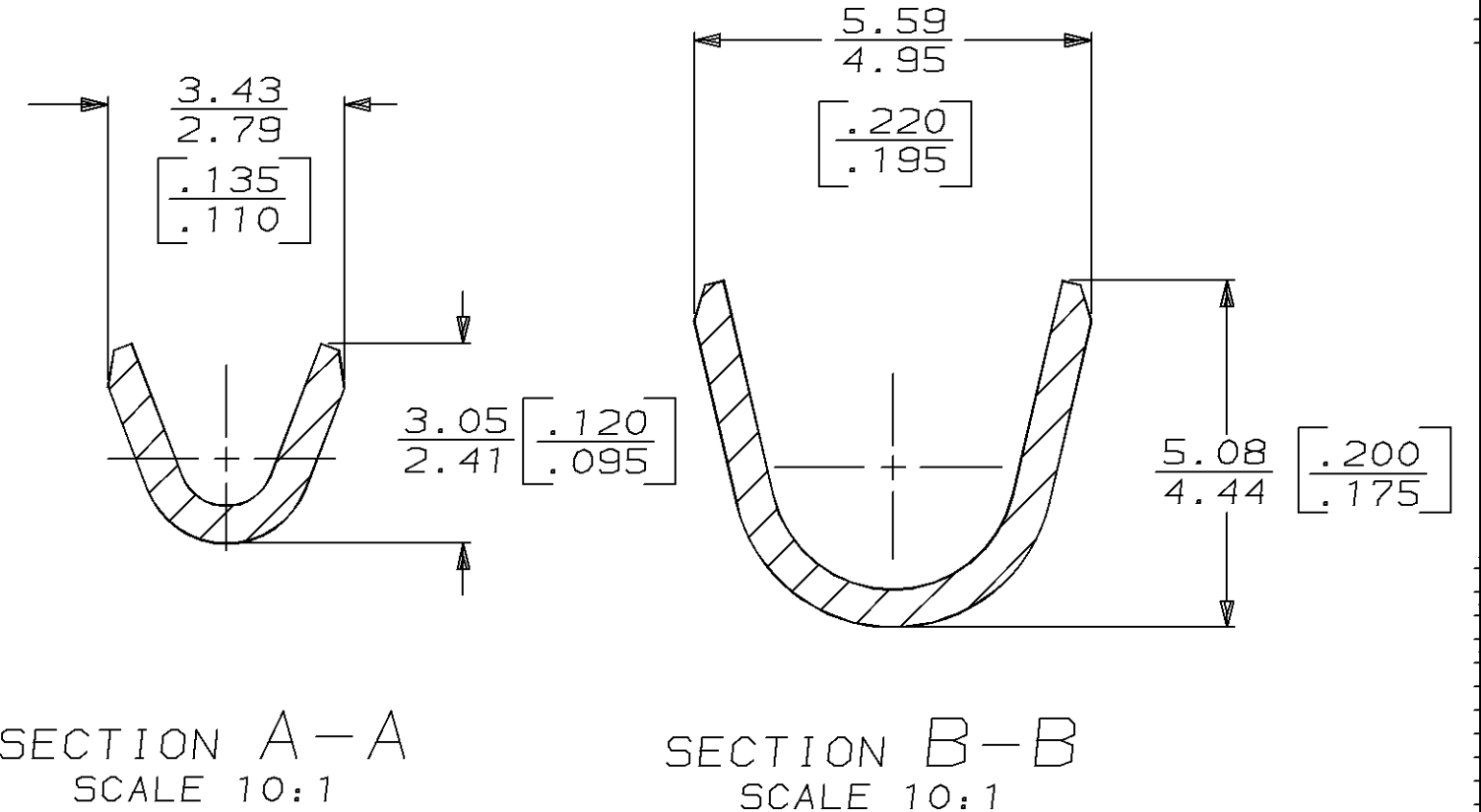
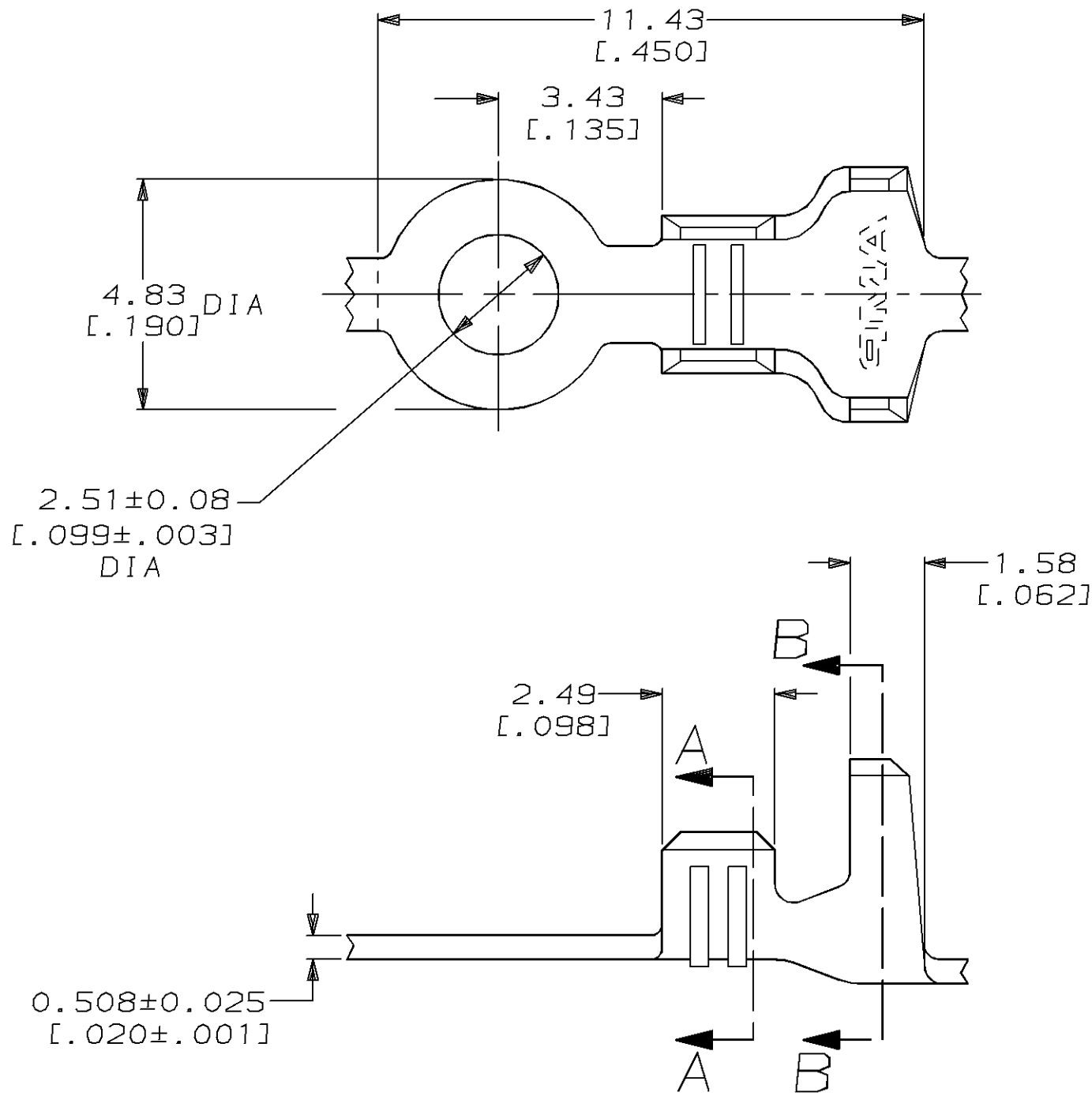

THIS DRAWING IS A CONTROLLED DOCUMENT FOR AMP INCORPORATED. IT IS SUBJECT TO CHANGE AND THE CONTROLLING ENGINEERING ORGANIZATION SHOULD BE CONTACTED FOR THE LATEST REVISION.

DO NOT SCALE PRINT. UNLESS SPECIFIED DIMENSIONS IN mm [INCHES] TOLERANCES ON: 2 PLC DEC ± 0.25 [.010] 3 PLC DEC ± - ANGLES ± -	DR 23/JAN/95 PHILLIP M FORTNEY CHK 23/JAN/95 MICHAEL S FEHER APPD 23/JAN/95 GARY YETTER APPD 23/JAN/95 MARK BARNABA PRODUCT SPEC - APPLICATION SPEC - WEIGHT -	2.79-3.81 [.110-.150] DIA	[22-20] AWG	60786-1
MATERIAL 082 BRASS	INSULATION RANGE	WIRE RANGE	PART NO	
FINISH -	AMP		AMP Incorporated Harrisburg, PA 17105-3608	
NAME RING		SIZE B	CAGE CODE 00779	DRAWING NO C-60786
SCALE 8:1		SHEET 1 OF 1		