

Key Features:

- **Tiny size** – 3.5cm x 2.8cm (1.38" x 1.1")
- **Use case:** IoT devices, Arduino, Beagle, Raspberry-Pi, ODriod, others.
- **Output:** Micro-USB or solder, UPS 5V, 3A max via micro-USB.
- **Input:** Micro-USB or solder, 5V, 3A power adapter.
- **UPS Battery:** Li-Ion or Li-Polymer batteries.
- **Charging:** max 2A, CC-CV.
- **Monitoring:** GPIO for Power failure. I²C for monitoring Vin, Vout, Battery V, Temp. 3.3V pull up for I²C provided externally.
- **LED's:** LED indicators for battery charging, UPS, Power.
- **Safety:** All electronics are turned off when battery V drops below 2.6V. Battery charges immediately when power is restored. Temperature controlled charging. Drained battery trickle charge. Over current protection.
- **Low Drain:** Charged battery remains charged for a long time.
- **ESD/Surge:** Input protected by TI Surge Protection Device. Protection for power surges and ESD.

Tiny-UPS

Worlds tiniest UPS with I²C & GPIO. Ideal for IoT devices, Raspberry Pi, Arduino, others.

3.5cm x 2.8cm (1.1"x1.38") full feature UPS.

Tiny-UPS provides UPS for 5V USB or other power via an external Li-Polymer or Li-Ion battery (batteries are not included). Size and capacity of the battery does not matter to Tiny-UPS. The charge time and run time will change depending on the capacity of the battery. Tiny-UPS is an ideal power source for IoT devices and a Single Board Computer (SBC) such as Raspberry Pi, Arduino, ODriod™, Android devices and other USB devices. Mounting holes allow Tiny-UPS to be mounted on a Raspberry Pi-Zero as well as the Adafruit™ ADS1115 (or ADS1015) ADC boards.

UPS functionality can be monitored using a built in ADC or by using the GPIO on Tiny UPS. A built in ADC gathers operating information and reports back the information via I²C. A separate pin allows for 3.3V (or 5V) pullup power for the I²C. Please make sure this pin is connected to a power pull up. Sample Python code monitors operating parameters and can shutdown unit when battery falls below a specified threshold.

GPIO indicates when power has failed. GPIO is high (3.3V) when power is on. GPIO is low (0V) when power has failed. The GPIO status can be used as a simple metric to time how long the UPS can operate before it needs to be shut down if your system does not have I²C capabilities. GPIO signals conform to 0V (low) and 3.3V (high).

Tiny-UPS recommends a micro-USB power source capable of providing 5V, 3 Amps. Power on is indicated via the GPIO or by the **Green LED**. Battery charging by **Yellow (Amber) LED**. This LED goes off when battery is fully charged (at 4.2V). A **blue LED** indicates UPS operation when Input Power has failed.

When power is on, the output is powered and the battery is being charged, creating a parallel power path for battery charging and for Output Power. When Power fails, the battery V is boosted to 5V and the switch over is seamless.

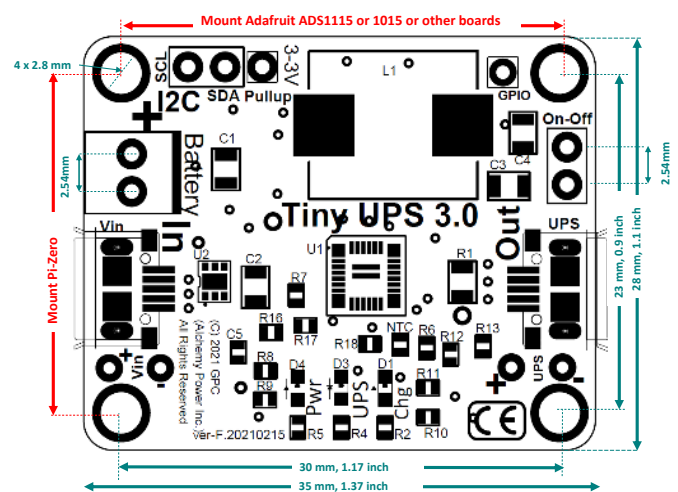

Key Features

- UPS functionality – seamlessly switches over from mains power to battery backup power.
- Choice of Li-Ion or Lithium-Polymer battery. Maximum battery charge Voltage for battery is 4.2V. Please use batteries rated for 4.2V and minimum of 3A. Please do not use any other battery chemistry.
- Battery is connected to terminal block soldered on system.
- Battery charge current is limited to 2A. Battery is charged using CC-CV charging method. Depleted batteries are charged initially at a trickle charge current of 125mA to allow depleted batteries to recover gracefully.
- Input Power surge protected by 5V clamped TVS. Prevents power spikes and protects the electronics.
- Tiny-UPS output is regulated to be 5V ($\pm 1\%$), 3A max. Power Path control enables simultaneously use of Tiny-UPS and battery charging. When power fails, the UPS functionality takes over. UPS power lasts if the battery is more than 3V.
- Input Electronics are protected against power surges by using a TVS. This ensures flawless and long-life under transient power, e.g., automobiles, refrigeration and other motor-based inductive power surges or other noisy environments.
- I²C allows monitoring of Input V, Battery V, Output V, Temperature (measured by NTC). The ADC is a 12-bit ADC and can monitor these parameters frequently. Sample Python code for the Raspberry Pi is provided.
 - Allows two I²C addresses. To change I²C address, cut the SHUNT at the bottom of the board.
- When I²C is not available or useable, the GPIO pin can be used to indicate power failure. A simple mechanism such as a timer can be used on the host computer to compute when the host should be shut down¹. GPIO can also be used to indicate when Power has failed, along with the I²C to ensure proper operation.
- LEDs indicate Power On via the **GREEN LED**, UPS Operational via the **BLUE LED**, and battery charging via the **Yellow (Amber) LED**. The charging LED turns off when the battery is fully charged. UPS LED is on when the UPS is operational.
- Power is shut off when battery V is 2.6V or lower.
- Battery will start charging and power is sourced from power supply when power is restored. When Power is present, the power path provides power to output and charges the battery in parallel. The Power Path to the output has a higher priority than battery charging.
- Some soldering is required for connecting battery and GPIO for terminal blocks, connections etc.
- Four mounting holes, 2.8mm diameter allow Tiny-UPS to be mounted on a Raspberry Pi-Zero as well as other boards such as the Adafruit ADS 1x15. Use 2.5mm spacers. **Please use insulated or Nylon mounting hardware**. Some use-cases:
 - Mount to a Raspberry Pi-Zero using the 23mm mounting holes.
 - Mount an Adafruit Analog-Digital-Converter ADS1x15 to monitor additional parameters or monitor other sensors.

The mount points provide mechanical stability.

- Tiny-UPS can use protected or unprotected Lithium Ion or Lithium Polymer batteries.
- Tiny UPS can be used with USB chargers. Please make sure good quality USB charger and good quality USB cables are used with Tiny-UPS. Poor quality USB charge cables will cause a Voltage drop. Make

¹ This method is not accurate and is recommended to use the I²C for a more accurate measurement.

sure good quality (22 Gauge or better) USB cables are used². On Tiny-UPS, Input Voltage can vary from 4.6V to 5.5V to compensate for poor quality USB power or power adapters placed far away.

- Instant on – power to the output is available as soon as power is restored.
- Maximum charge current – 2.0 Amps.
- Maximum output current – 3.0 Amps. Please ensure that the batteries can support a minimum of 3.0 Amps. Also ensure that the power adapter (power supply) can support 3A or more.
- Output Voltage converter average efficiency of ~90% provides a very efficient system with minimal losses.
- Intelligent Battery Charge Management (BCM) manages all aspects of battery charging as well as maintaining the charge when the unit remains plugged in.

Please visit www.alchemy-power.com/products for additional information and sample python code. Some soldering required.

Picture Gallery / Other Information

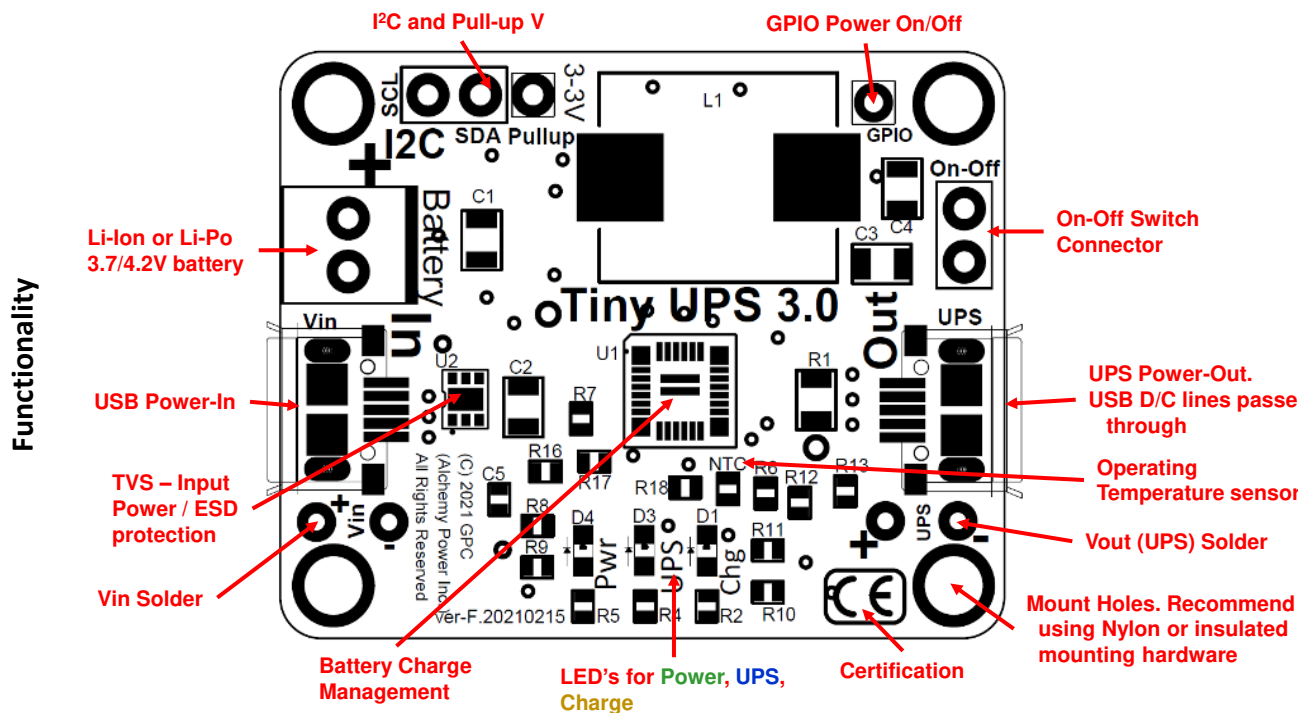

² Please make sure to only use high quality USB chargers and USB cables with Tiny-UPS. Poor quality USB cables cause voltages to drop.

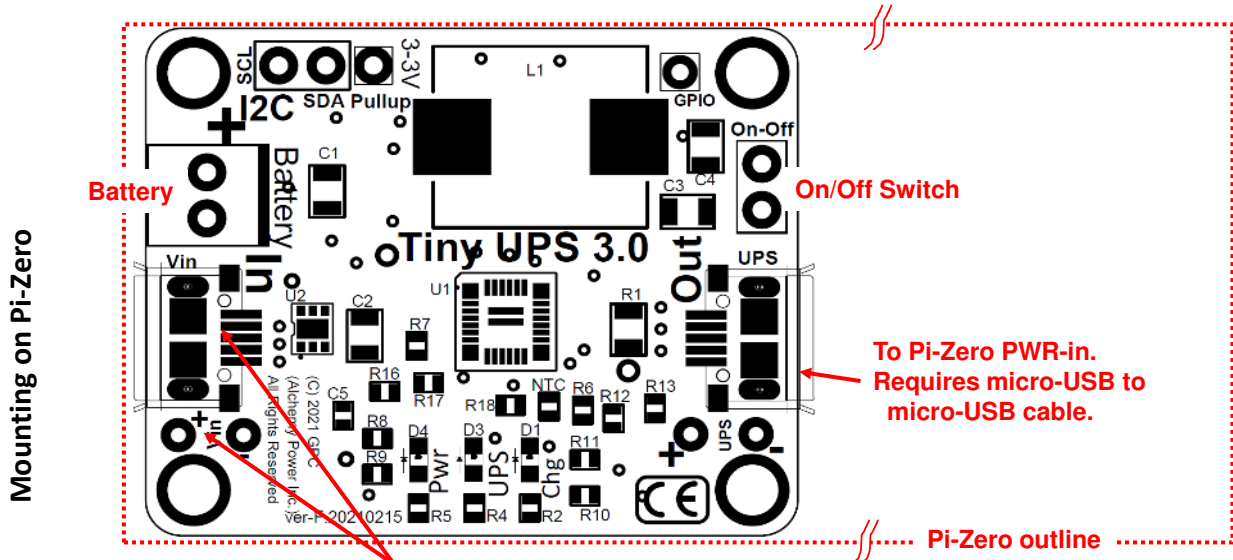
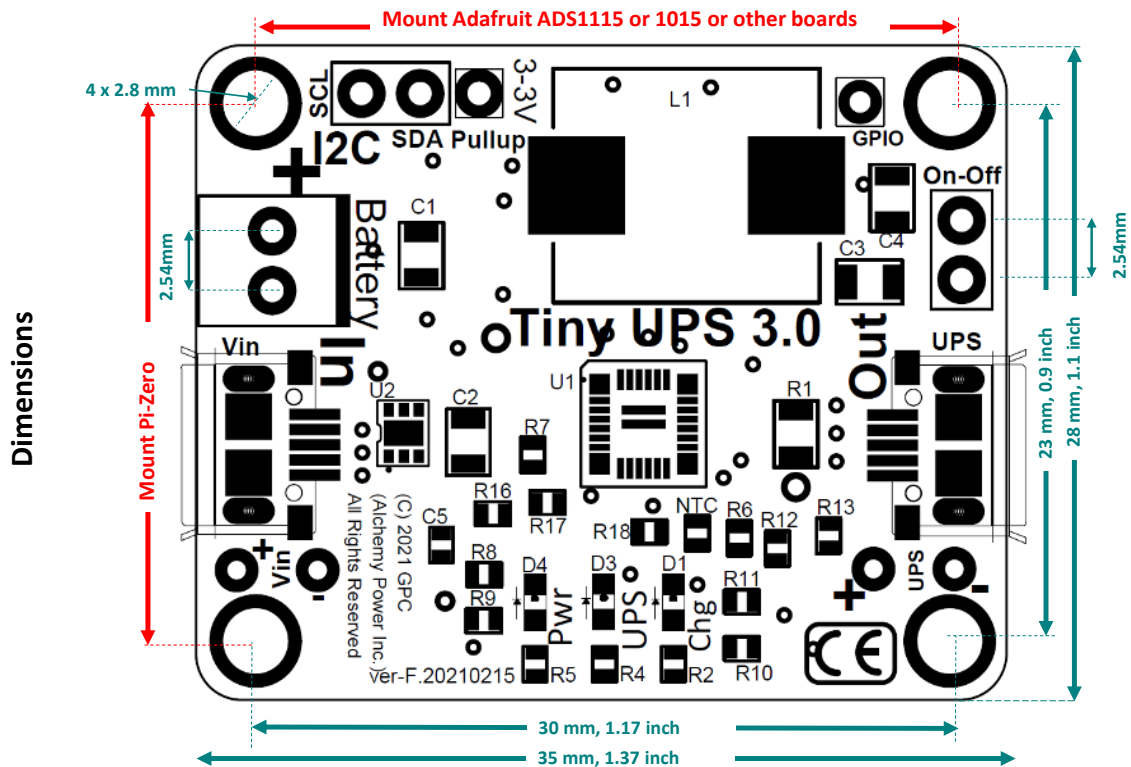

Power In – use one of this to Power Tiny-UPS and charge battery.

To Pi-Zero PWR-in. Requires micro-USB to micro-USB cable.

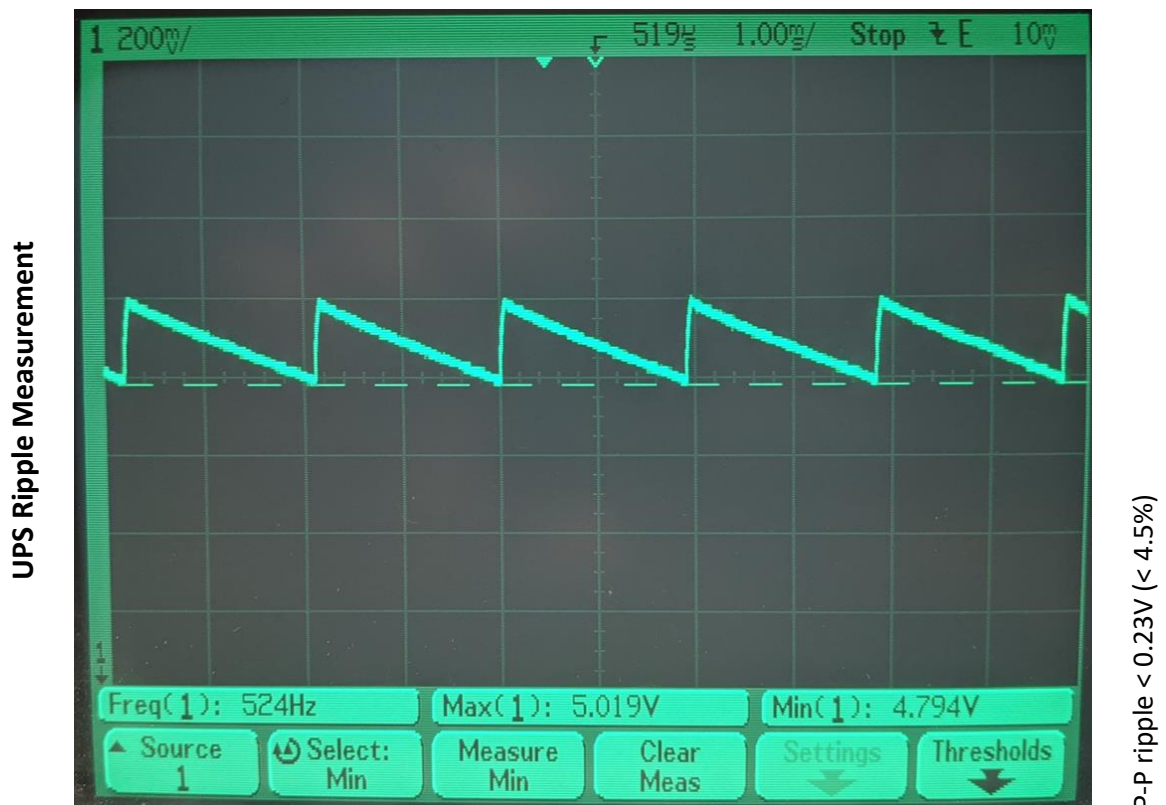
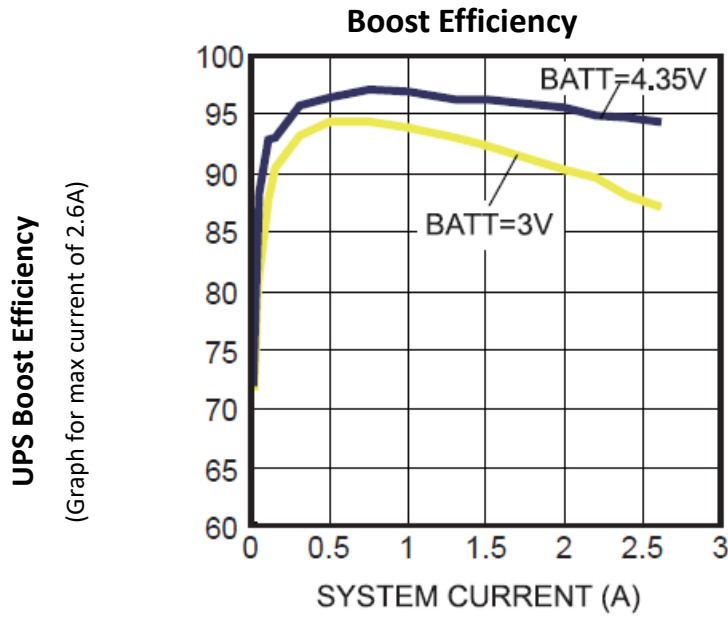

Powering a Pi-3B+. Monitoring via I²C.

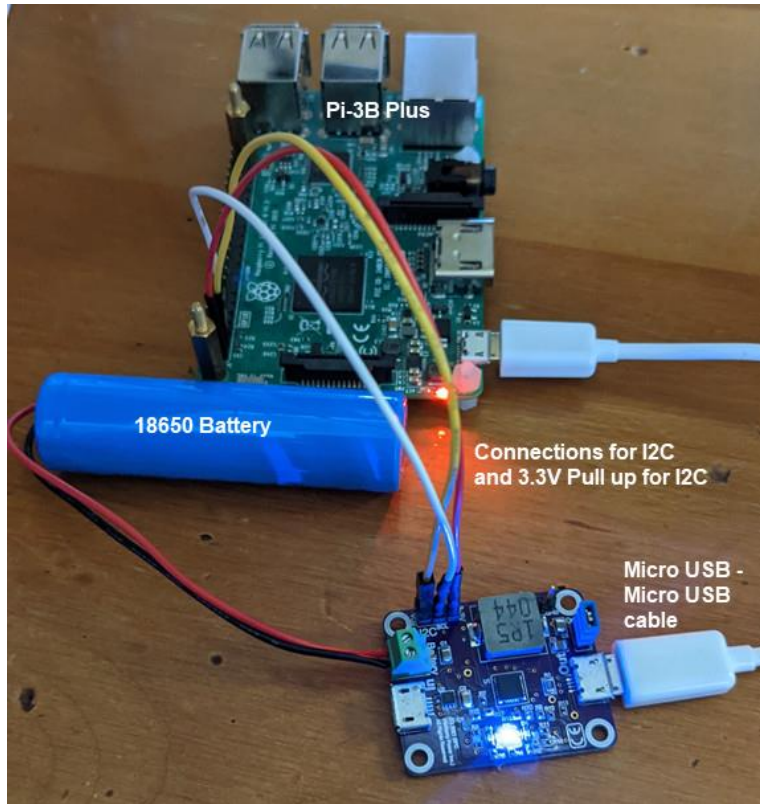

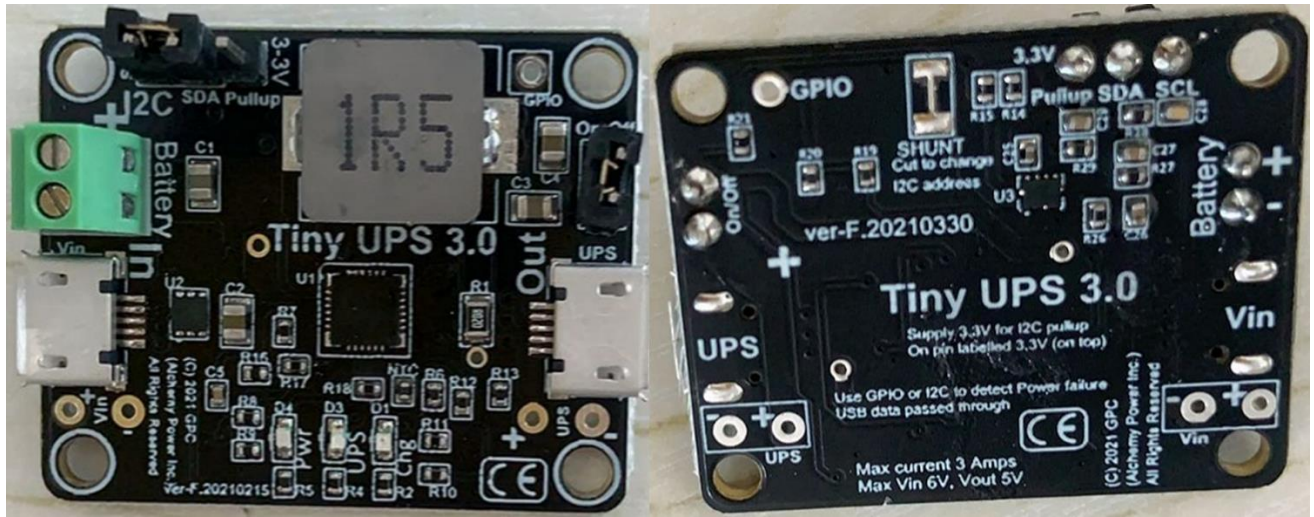

Top and Bottom Views

Intentionally left blank.

Specifications

General Information

Model Number: Tiny-UPS

Devices

5V UPS: Any IoT device, Single Board Computer (SBC) which needs 5V and 3A (or less) as a power source.

Mounting: Mounting holes match Raspberry Pi-Zero as well as ADC boards from Adafruit™. Mounting can be 23mm apart (eg. Raspberry Pi Zero) or 30mm apart (e.g. Adafruit boards).

Spacers: Mounting holes are 2.8mm. M2.5 screws or M2.5 spacers are recommended. Note: M3 spacers will not fit.

Power

Input Power: Power supply with 4.6V to 5.5V, 3A to 5A recommended. Power-in on “In” Port.

Power Protection: TVS 5V clamp protects against power surges and ESD.

Power connectors: micro-USB or solder points for Power-In and Power-Out.

Power Adapter: 5V 3A USB power adapter, not included.

Maximum Charge Current: 2.0 Amps.

Maximum Output Current: 2.9 Amps.

Ripple: Appx 225mV p-p.

Output Voltage: 4.794V to 5.019V, RMS 4.9011V

Battery Low Trigger: Set in Software (sample Python Code provided).

Battery Low hard shutdown: At 2.5 V, all power is off, and the electronics are shuts down.

Operating Frequency: 600kHz.

USB

UPS Power: 4.9 V to 5.08 V (usually 4.99V) via micro-USB Out port. UPS Power on “Out” port.

USB Data: Passed through between In and Out ports for D+, D- and ID.

Batteries

Batteries: 4.2V Lithium Ion or Lithium-Polymer (Li-Po) battery. Battery can be protected or unprotected.

Battery capacity: Battery charging is based on CC-CV method and is independent of capacity. Charging time will vary based on battery capacity. Max charge current is 1A.

LEDs: **Power on green, Charge (completed) Amber / Yellow, UPS Operational – Blue.**

Battery polarity: As indicated on Tiny-UPS. **Inserting batteries incorrectly will damage the electronics and can cause the board to get very hot.**

Safety: Onboard Battery Charge Management (BCM) prevents over charging and deep discharging. On-board circuit detect when battery is at 3V or lower. Onboard NTC measures temperature and prevents charging when its too hot (> 50C) or too cold (< -4C). Current limits for input and output current of ~3A.

Input Power Safety: PTC protects the electronics against power surges and ESD (max 2KV).

Battery Charging: Uses CC-CV charging method. Max charge current 2A. Max trickle charge 250 mA (150mA typical).

Depleted Batteries: Senses depleted batteries (2.9V or lower) and uses low current charging, around 100mA, to bring charge level up. Once the battery level reaches 2.93V or more, CCCV charging is initiated.

Battery Full Charge Voltage: 4.2V

Typical Battery V: 3.7V (Li-Ion or Li-Polymer battery).

Trickle Current: When input Voltage is off; and load is disconnected, Tiny-UPS consumes very little power. However, the UPS LED will remain on. The LED consumes appx 2mA. To protect battery drain, it is recommended to disconnect the battery when device is not in use.

GPIO

Voltage: 0 V to indicate GPIO state zero, when power fails. 3.3 V indicates “high” GPIO state. GPIO trickle current appx 17 μ A.

V-In: Input Voltage is monitored using the GPIO sense point. When GPIO is High, Power is on. When GPIO is low, Power is off.

USB

USB: micro-USB connectors for In and Out. Connect Power to In-port. UPS power available on Out-port. All connections are passed through from In to Out, thus the USB ports can be used for data or other functions.

I²C

Address: Default address is 0x48. A second address is available (0x40) by cutting the shunt wire on the bottom of the board. The connector is labelled SHUNT on the bottom.

ADC

Channels: 4 Channels. Connected to measure Input V on Channel 0, Battery V on Channel 1, Output V on Channel 2 and Temperature on Channel 3. See sample Python Code.

Capability: 12 bits. Appx 2.4mV per bit.

Access: Information accessed via I²C. ADC is connected to the I²C bus and operates as long as output 5V is available i.e. UPS is operational.

Spacers

M2.5mm. **Use only Nylon spacers. Do not use metal spacers or screws to secure spacers.** Vin, Vout solder points are close to the mounting holes and some screw heads may cause a short circuit. Spacers are not included.

On-Off Switch

Power On/Off: An on/off switch can be connected to Tiny-UPS at the “on-off” location. Connectors are spaced 2.54mm apart. Connect an external on-off SPST switch if needed. Switch is not provided.

Dimensions

Board dimensions: 35mmx28mmx3mm (1 3/8”x 1” x 0.12”).

Weight: About 5g (0.2 oz).

Headers (Battery Connectors): Use 2.54 mm terminal blocks (e.g., TE 282834-2 or On-Shore OSTVN02A150) or 2.54mm jumpers / connector blocks. Alternately, solder wires directly to the board. JST connectors can also be used. **PLEASE MAKE SURE THE BATTERY IS CONNECTED PROPERLY AND POLARITY IS NOT REVERSED.**

REVERSING BATTERY POLARITY WILL DAMAGE THE ELECTRONICS.

Warranty

90-day limited warranty. Warranty voided by improper use.

Other Information

Temperature: Li-Ion batteries usually operate from 0°C to 40°C. It is recommended to use the board in the operating range of the battery.

Operating Humidity: 10% to 80% non-condensing.

RoHS Compliance: Electronic components, board etc. are RoHS compliant.

REACH Compliance: All components are sourced from reputable manufacturers, who comply with REACH requirements.

CE Compliance: Compliant as low V device.

Other peripherals:

Please visit www.alchemy-power.com/products for other recommended products.

Code download:

www.alchemypower.com/downloads

Product Video: To be added later.

Raspberry Pi, Adafruit, Odroid, Arduino and other Trademarks as shown in the document and belong to the respective trademark holders. Please refer to the respective organizations for Trademark, right of use and other information.



Product UPC (Bar Code) label UPC Code: 708088-352553

GP Consulting Inc.

(Owner of Alchemy Power Inc. IP)

Phone: 650.823.2316

Email: sales@alchemypower.com

www.alchemypower.com