

Long Range Metal Body Sensor

E3S-C



30 m Range With Advanced Fuzzy Logic

- Mutual interference protection
- NPN/PNP switch selectable output
- M12 plug-in connector
- Meets IP67 and NEMA 4X, 6P
- Vibration resistance of 10 Hz to 2 kHz and a shock resistance of 1,000 m/s² (approx. 100 G)

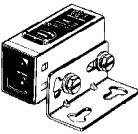

Ordering Information

■ SENSORS

Mounting	Method of detection	Sensing distance	Part number	
			Pre-leaded	Connector
Horizontal 	Through-beam	30 m (98.43 ft)	E3S-CT11	E3S-CT16
	Polarized retroreflective	3 m (9.84 ft)	E3S-CR11	E3S-CR16
	Diffuse reflective	70 cm (27.56 in)	E3S-CD11	E3S-CD16
2 m (6.56 ft)		E3S-CD12	E3S-CD17	
Vertical 	Through-beam	30 m (98.43 ft)	E3S-CT61	E3S-CT66
	Polarized retroreflective	3 m (9.84 ft)	E3S-CR61	E3S-CR66
	Diffuse reflective	70 cm (27.56 in)	E3S-CD61	E3S-CD66
		2 m (6.56 ft)	E3S-CD62	E3S-CD67

■ ACCESSORIES

Description	Part number
Slits for E3S-CT□□ sensors (4 pairs: 0.5 mm, 1.0 mm, 2 mm, and 4 mm wide, includes mounting hardware)	E39-S61
Mounting bracket for E39-R1 reflector	E39-L7

■ CONNECTOR CABLES

Connector type	Cable size	Length	Straight connector	Right angle connector
3-wire DC MicroChange®	22 AWG	2 m (6.56 ft)	Y96E-43SD2	Y96E-43RD2
		5 m (16.40 ft)	Y96E-43SD5	Y96E-43RD5
		10 m (32.8 ft)	Y96E-43SD10	Y96E-43RD10

REPLACEMENT PARTS

Description	Part number
Mounting bracket for E3S-C□1□ (horizontal)	E39-L102
Mounting bracket for E3S-C□6□ (vertical)	E39-L103
Reflector (supplied with retroreflective sensors)	E39-R1

Specifications

Part number		E3S-CT11 E3S-CT61 E3S-CT16 E3S-CT66	E3S-CR11 E3S-CR61 E3S-CR16 E3S-CR66	E3S-CD11 E3S-CD61 E3S-CD16 E3S-CD66	E3S-CD12 E3S-CD62 E3S-CD17 E3S-CD67
Method of detection		Through-beam	Polarized retroreflective	Diffuse reflective	
Supply voltage		10 to 30 VDC, ±10%			
Current consumption		50 mA max. (emitter and receiver)	40 mA max.		
Sensing distance	White mat paper	0 to 30 m (0 to 98.43 ft)	0 to 3 m (0 to 9.84 ft)	0 to 70 cm (0 to 27.56 in)	0 to 2 m (0 to 6.56 ft)
	With accessories	4-mm slit: 15 m 2-mm slit: 7 m 1-mm slit: 3.5 m 0.5-mm slit: 1.8 m	E39-R2: 0 to 4 m E39-R3: 0 to 150 cm E39-R4: 0 to 75 cm E39-RSA: 5 to 35 cm E39-RSB: 5 to 60 cm	—	
	Minimum object size	4-mm slit: 2.6-mm dia. 2-mm slit: 2-mm dia. 1-mm slit: 1-mm dia. 0.5-mm slit: 0.5-mm dia.	E39-R1 Reflector: 13-mm dia. E39-R3: 8-mm dia. E39-R4: 4-mm dia.	—	
Light source		Pulse modulated infrared LED (880 nm)	Pulse modulated red LED (700 nm)	Pulse modulated infrared LED (880 nm)	
Standard object	Type	Opaque materials	Opaque materials	Opaque and transparent materials	
	Size	9 mm (3.54 in) min.	30 mm (1.18 in) min.	30 x 30 cm (11.81 x 11.81 in) white mat paper	
Operation mode		Light-ON/Dark-ON operation, switch selectable			
Variation in sensing distance		-		±10% max.	
Hysteresis		-		20% max. of sensing distance	
Variation in optical axis and mounting direction		±2° max.			
Sensitivity		Adjustable, 3/4 turn knob		Adjustable, 2-1/2 turn knob with clutch and indicator	
Mutual interference protection		Not provided	Provided		
Control output	Type	NPN or PNP (selectable), open collector current output			
	Max. load	100 mA max.			
	Residual voltage	NPN output: 1.2 V max., PNP output: 2.0 V max.			
Response time	OFF	1 ms max.			2 ms max.
	ON	1 ms max.			2 ms max.
Circuit protection		Output short-circuit protection, reversed polarity protection			
Vibration resistance	Destruction	10 to 2 kHz, 1.5-mm double amplitude, or 300 m/s ² (approx. 30G) 0.5 hrs each in X, Y, and Z axes			
Shock resistance	Destruction	1,000 m/s ² (approx. 100G) 3 times each in X, Y, and Z axes			

(This table continues on the next page.)

Part number		E3S-CT11 E3S-CT61 E3S-CT16 E3S-CT66	E3S-CR11 E3S-CR61 E3S-CR16 E3S-CR66	E3S-CD11 E3S-CD61 E3S-CD16 E3S-CD66	E3S-CD12 E3S-CD62 E3S-CD17 E3S-CD67
Indicators	Emitter	Power ON (red)		Stability indicator (green), Light Incident (red)	
	Receiver	Stability indicator (green), Light Incident (red)			
Materials	Lens	Acrylic			
	Case	Zinc die-cast			
	Operation panel	Sulfonated polyether			
	Bracket	Stainless steel			
Mounting		Either side surface with two threaded holes. Bracket for horizontal (E39-L102) or vertical (E39-L103) sensors and hardware included.			
Connections	Emitters	2-conductor cable, 2 m (6.56 ft) length or 4 pin, 12 mm connector	3-conductor cable, 2 m (6.56 ft) length (for prewired types)		
	Receiver	3-conductor cable, 2 m (6.56 ft) length or 4 pin, 12 mm connector			
Weight	Horizontal model	110 g (3.88 oz.)			
	Vertical model	115 g (4.06 oz.)			
Enclosure ratings	IEC 144	IP67			
	NEMA	1, 4X, 6P, 12, 13			
Ambient temperature	Operating	-25°C to 55°C (-13°F to 131°F)			
	Storage	-40°C to 70°C (-40°F to 158°F)			

■ OUTPUT CIRCUIT DIAGRAMS

Output configuration	Mode switch	Output transistor	Output circuits
NPN	Light-ON	ON when light is received.	<p>ZD : $V_Z = 39\text{ V}$ Note: Set the NPN and PNP output selector to NPN.</p>
	Dark-ON	ON when light is not received.	
PNP	Light-ON	ON when light is received.	<p>ZD : $V_Z = 39\text{ V}$ Note: Set the NPN and PNP output selector to PNP.</p>
	Dark-ON	ON when light is not received.	

Engineering Data

■ EXCESS GAIN RATIO

E3S-CT□6

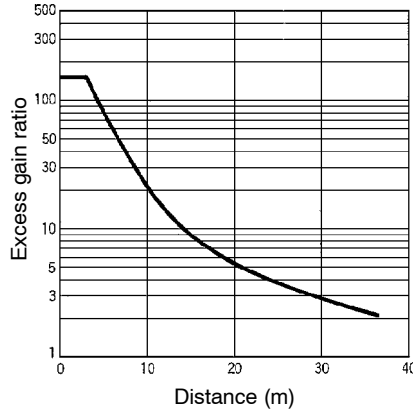

E3S-CR□6 (E39-R1 Reflector)

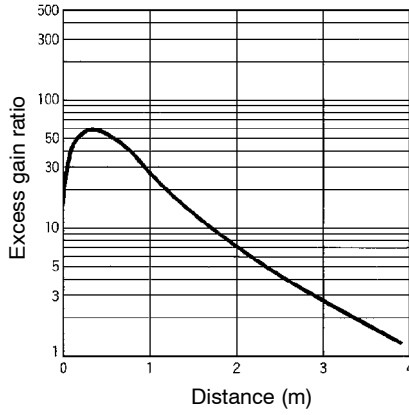

E3S-CD□6

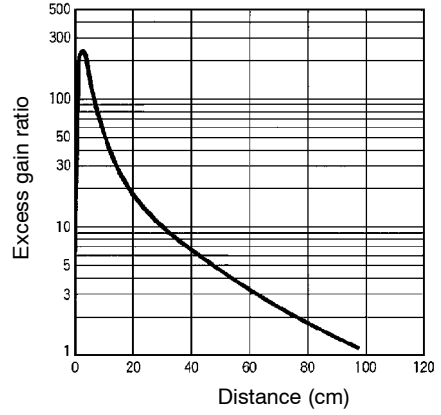

E3S-CD□2
E3S-CD□7

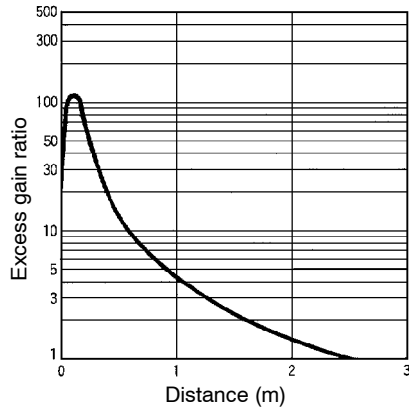

■ OPERATING RANGE

Parallel Operating Range (Typical)

E3S-CT□6

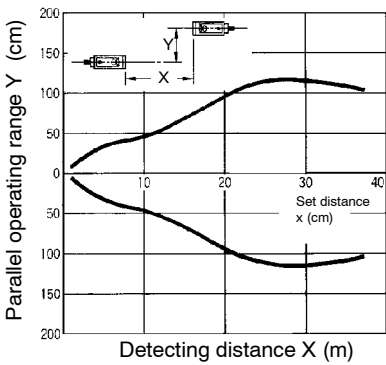

Operating Range (Typical)

E3S-CD□6 (Left and Right)

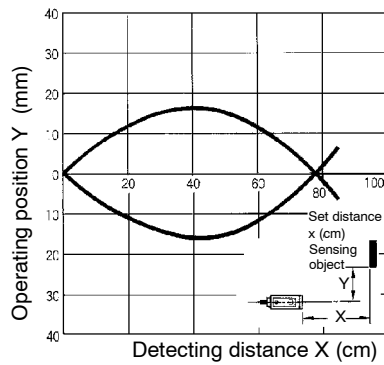

E3S-CD□7 and E3S-CD□2 (Left and Right)

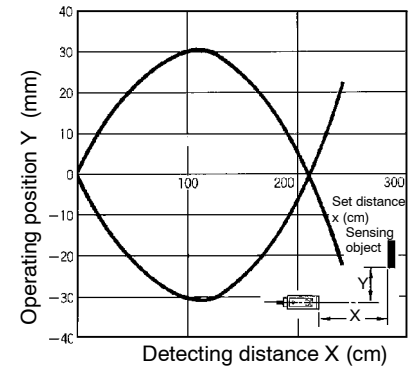

■ SENSING DISTANCE VS. OBJECT SIZE (TYPICAL)

E3S-CD□6

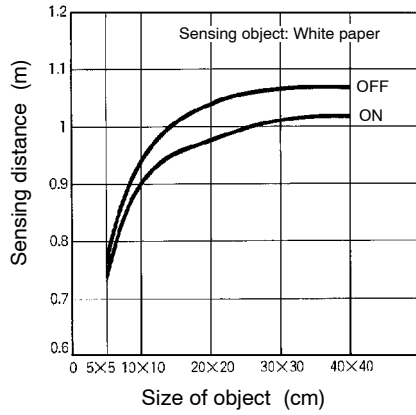

E3S-CD□7
E3S-CD□2

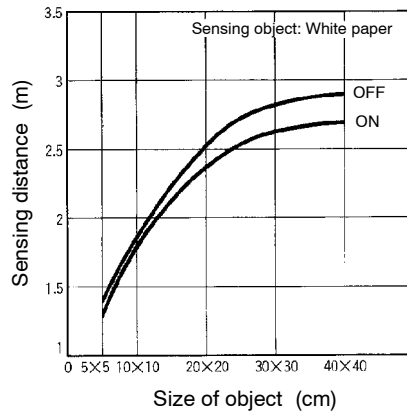

■ REFLECTOR PARALLEL MOVEMENT (TYPICAL)

E3S-CR□6

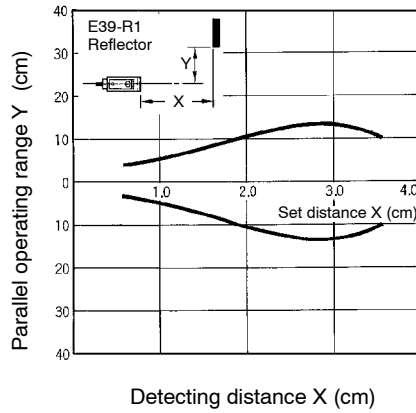

E3S-CD□7 and E3S-CD□2 (Up and Down)

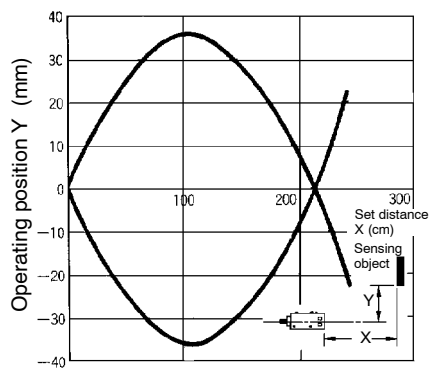

Dimensions

Unit: mm (inch)

SENSORS

E3S-CT11, E3S-CR11
E3S-CD11, E3S-CD12

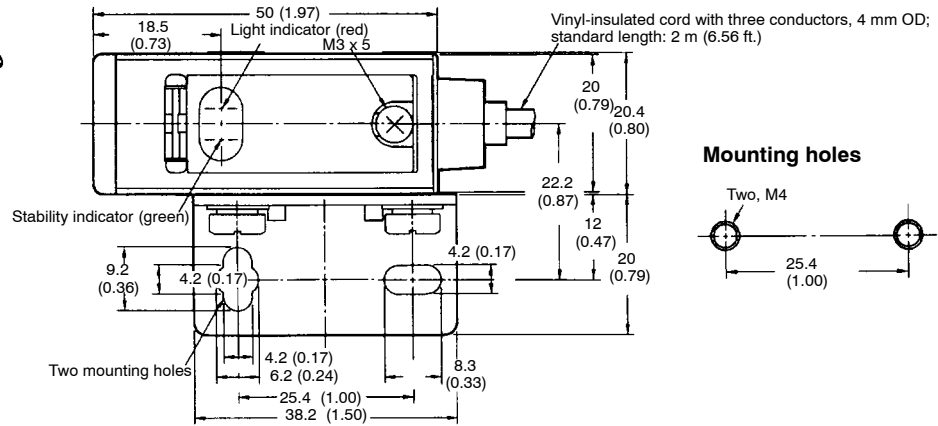
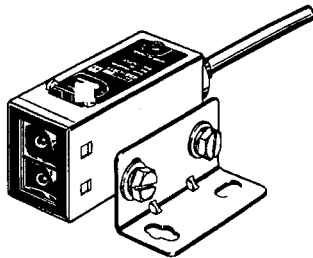

Mounting holes

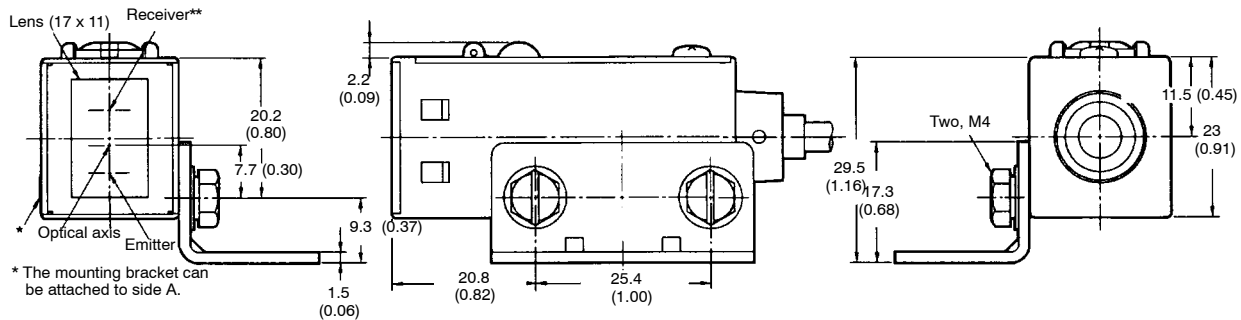
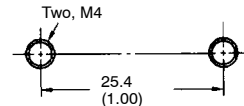

* The mounting bracket can be attached to side A.

** For E3S-CT11, optical viewing for the emitter and the receiver are from the top portion of the sensor.

**E3S-CT61, E3S-CR61
E3S-CD61, E3S-CD62**

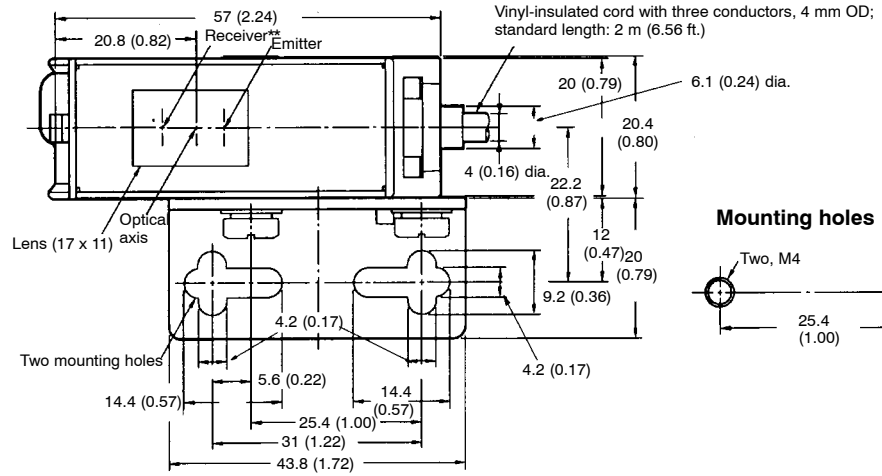
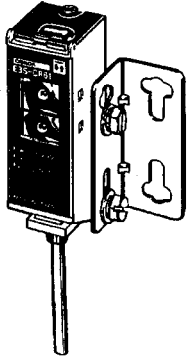

Stability indicator (green)

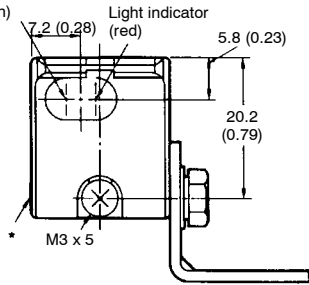

* The mounting bracket can be attached to side A.

** For E3S-CT61, optical viewing for the emitter and the receiver are from the top portion of the sensor.

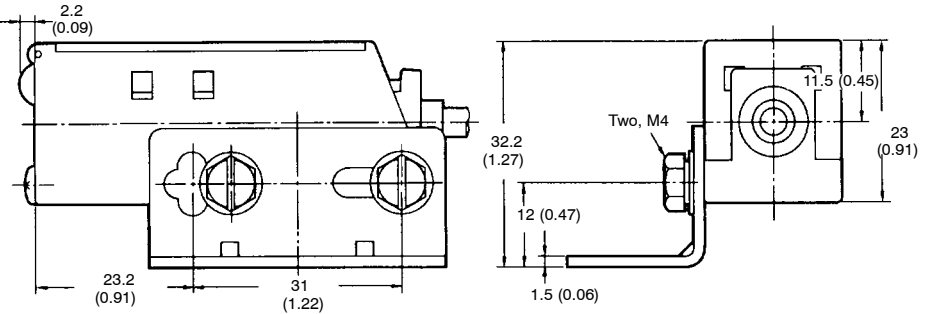

E3S-CT16

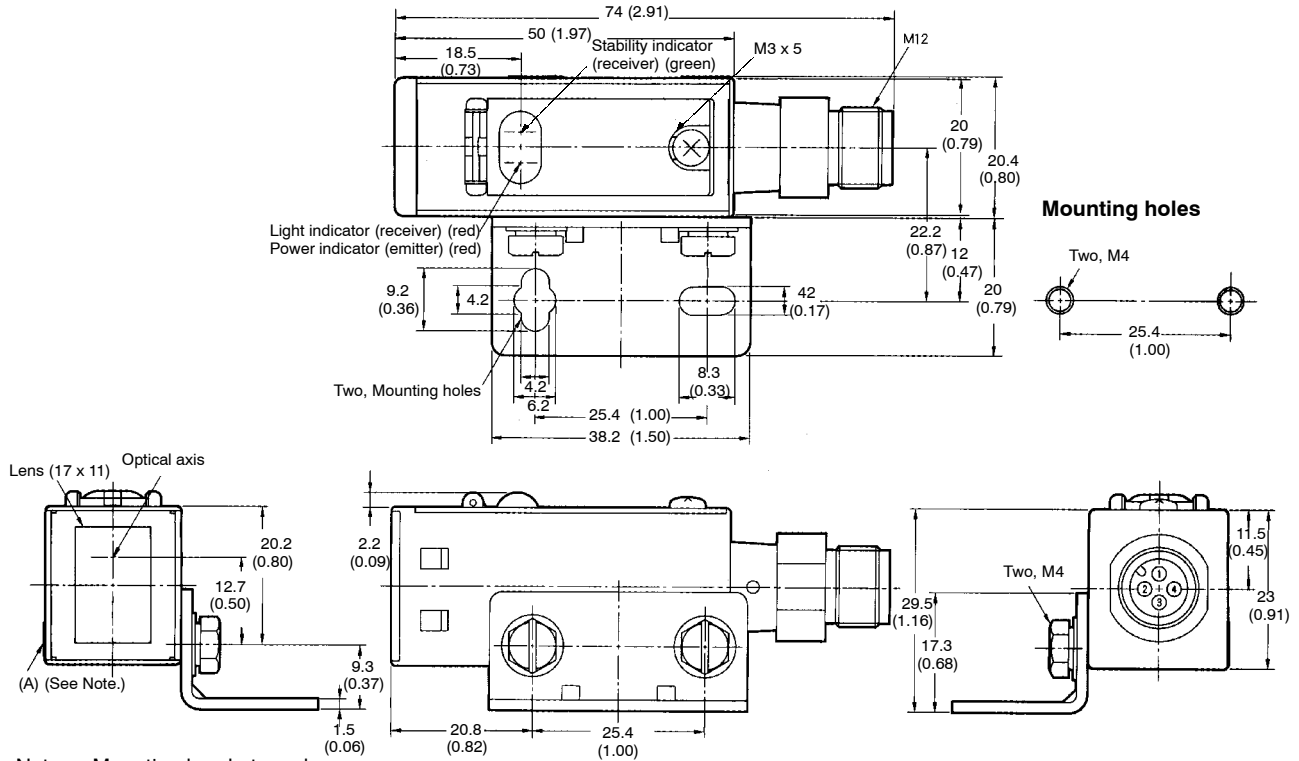

Note: Mounting bracket can be attached to side A.

E3S-CT66

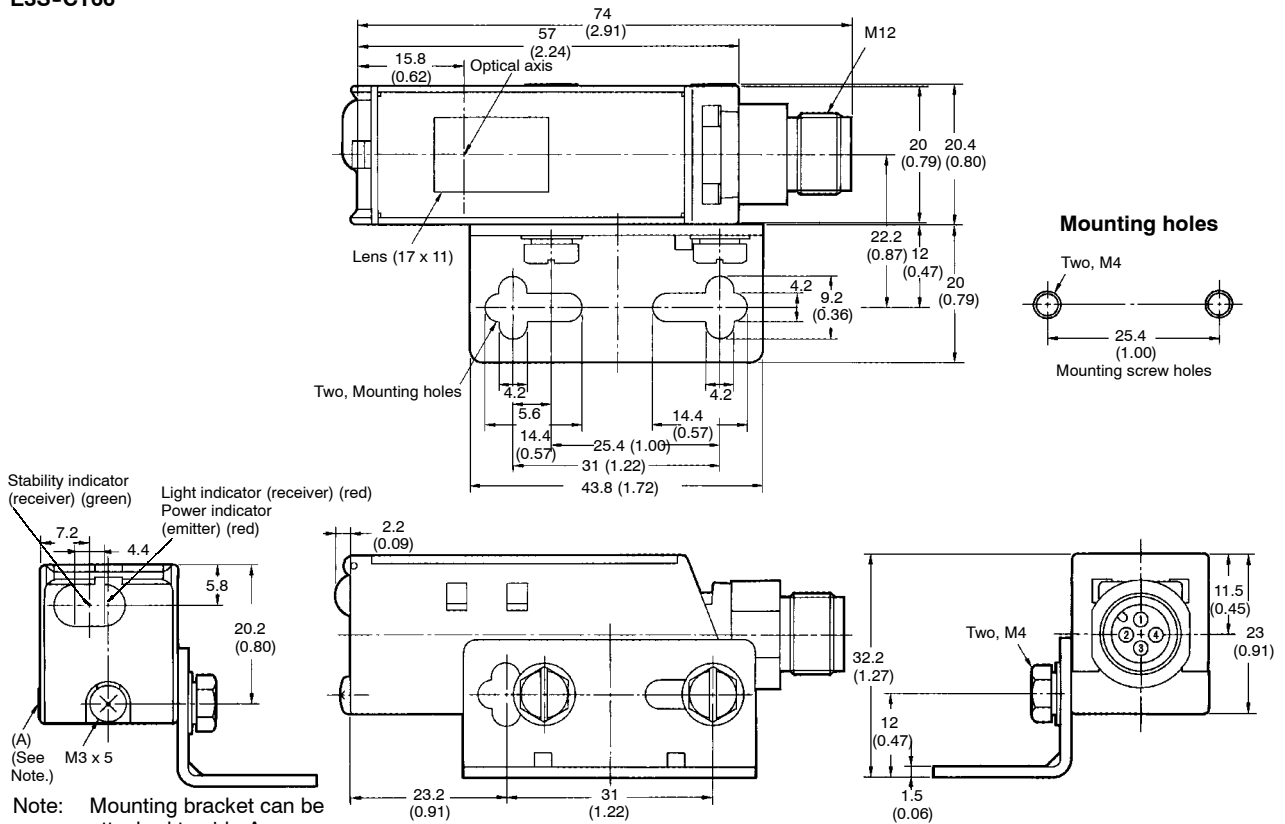

Note: Mounting bracket can be attached to side A.

E3S-CR16/-CD16/-CD17

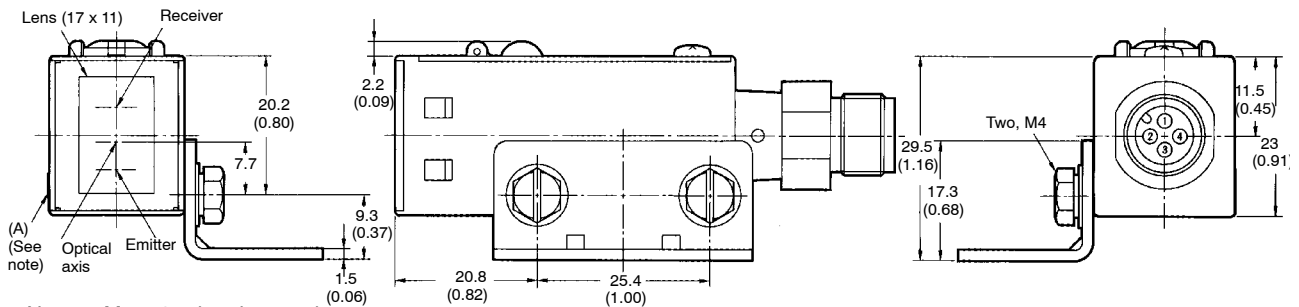
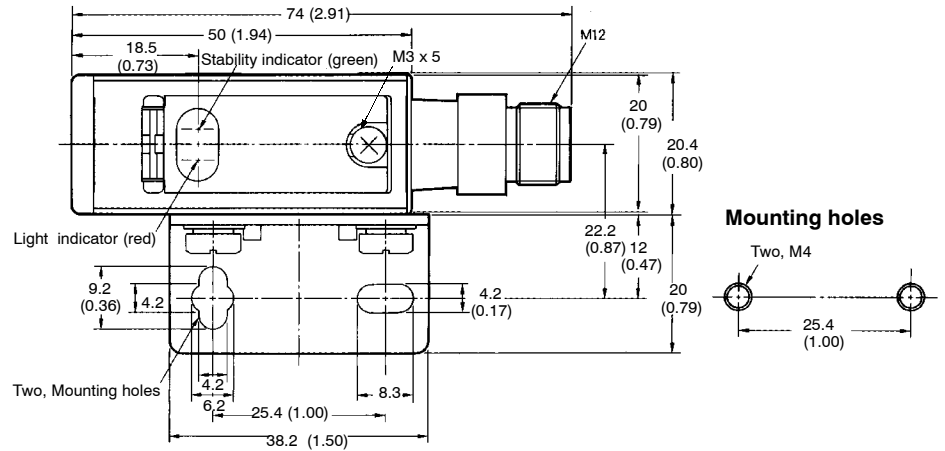

Note: Mounting bracket can be attached to side A.

E3S-CR66/-CD66/-CD67

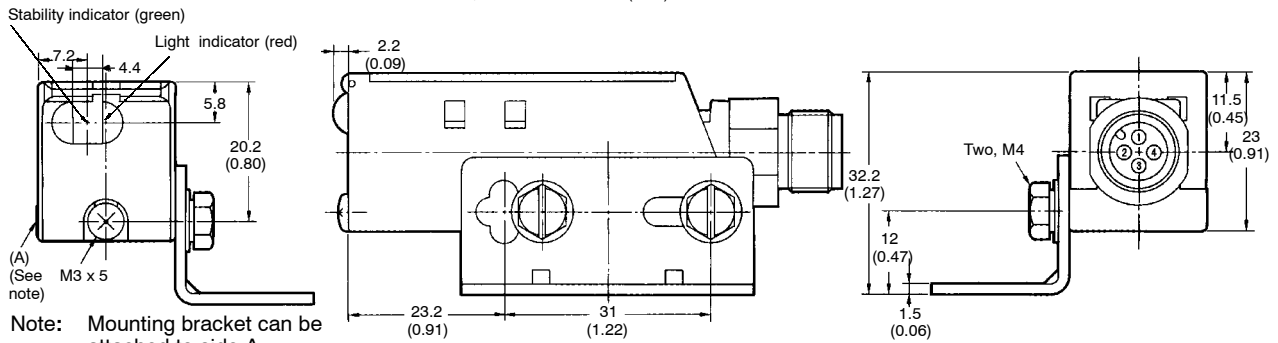
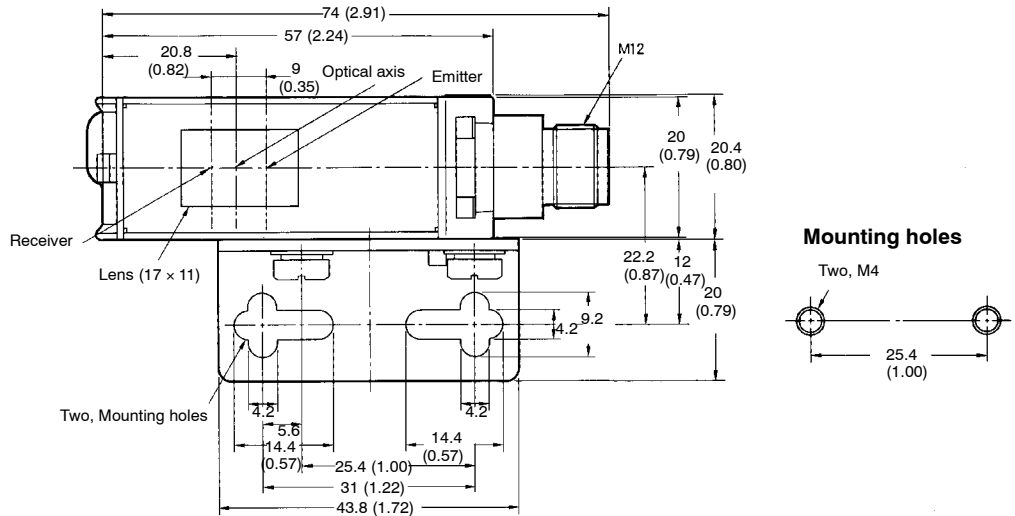

Note: Mounting bracket can be attached to side A.

■ CORNER CUBE REFLECTORS

E39-R1 Retroreflector

(Included with E3S-CR11/CR61)

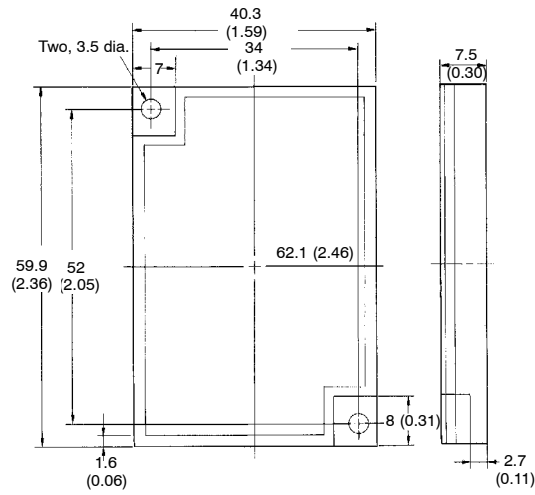
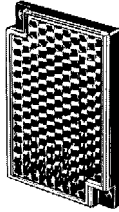

E39-S61 Slit Kit for E3S-C

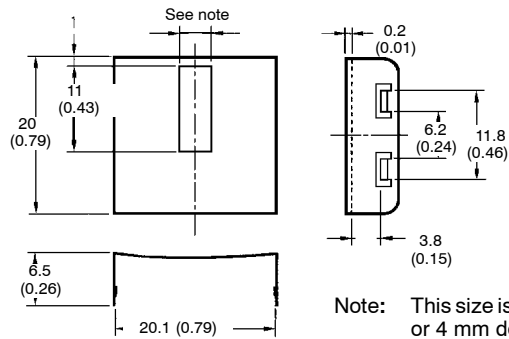
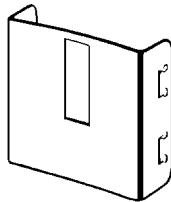

Note: This size is 0.5 mm, 1 mm, 2 mm, or 4 mm depending on the type.

Nomenclature

■ OPERATION PANEL

Use the NPN and PNP output selector on the operation panel to select the type of output transistor.

Use the Light-ON and Dark-ON selector on the operation panel to select the operation mode of the E3S-C.

Horizontal Model

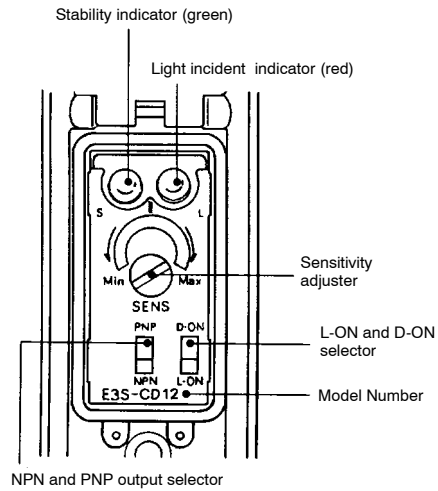

Vertical Model

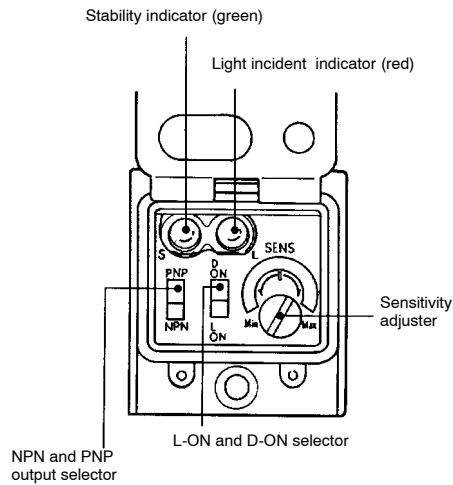

Operation

■ FUZZY LOGIC MUTUAL INTERFERENCE PREVENTION FUNCTION

(FOR E3S-CR□□ AND E3S-CD□□ ONLY)

If photoelectric sensors are installed side by side, each Sensor may be influenced (or malfunction) by the light emitted from the other sensors. This is known as mutual interference.

The fuzzy logic mutual interference prevention function of the E3S-C enables the E3S-C to monitor light interference over a certain period of time. Before the E3S-C starts emitting light, the E3S-C retrieves the intensity and frequency of surrounding light interference as data. Using this data, the E3S-C calculates, with fuzzy inference, the risk of the E3S-C malfunctioning and controls the timing of the E3S-C's light emission.

When the risk is low, the E3S-C waits until there is no light interference and emits light.

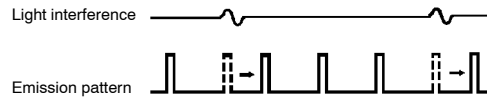

When the risk is high, the E3S-C emits light between each light interference moment.

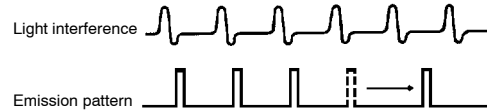

■ SENSITIVITY ADJUSTMENT (REFLECTIVE SENSORS)

Steps	Step 1	Step 2	Step 3
Function	Determine position A	Determine position B	Adjust to optimum setting
Sensing condition			
Sensitivity adjustor			
Indicators	OFF <input type="checkbox"/> STABILITY (green) ON <input checked="" type="checkbox"/> LIGHT (red)	OFF <input type="checkbox"/> STABILITY (green) OFF <input type="checkbox"/> LIGHT (red)	OFF <input checked="" type="checkbox"/> STABILITY (green) ON <input type="checkbox"/> LIGHT (red)
Procedure	Place target at the desired sensing distance. Set sensitivity adjuster to the minimum scale position, and gradually increase sensitivity by turning the sensitivity adjuster clockwise until the Light Incident indicator (red LED) turns ON. Position A designates the point at which the LED has turned on.	Remove the target. Starting from the maximum scale position, gradually decrease sensitivity by turning the sensitivity adjuster counterclockwise until the Light Incident indicator (red LED) turns OFF. Position B designates the point at which the LED has turned OFF.	Set the sensitivity indicator to the position between Positions A and B (in some cases, Positions A and B are opposite of the above example). The photoelectric sensor will then work normally if the stability indicator (green) is lit with and without the target. If it is not lit, stable operation cannot be guaranteed, in which case a different detection method should be applied.

Unlike conventional photoelectric sensors, the variation in the sensitivity among several E3S-C photoelectric sensors is minimal. This means the sensitivity can be adjusted on only a single photoelectric sensor, and then the adjusters on the other E3S-C photoelectric sensors can be set to the same scale position. There should be no need to adjust the sensitivity of each photoelectric sensor individually.

Precautions

■ CONNECTION

If the input/output lines of the photoelectric sensor are placed in the same conduit or duct as power lines or high-voltage lines, the photoelectric sensor could be induced to malfunction, or be damaged, by the electrical noise. Either separate the wiring, or use shielded lines as input/output lines to the photoelectric sensor.

The cord connected to the E3S-C can be extended up to 100 m provided that the diameter of each wire of the cord is 0.3 mm² minimum.

■ POWER SUPPLY

If the standard switching regulator is used as a power supply, the frame ground (FG) terminal and the ground (G) terminal, on the power supply, must be grounded. If this is not done the E3S-C may malfunction, due to the switching noise of the power supply.

If an inverter motor or servomotor is used with the E3S-C, the frame ground (FG) terminal and the ground (G) terminal, on the motor, must be grounded, otherwise the E3S-C may malfunction.

■ WATER RESISTANCE

To ensure the water resistance of the E3S-C, tighten the screws of the operation panel cover to a torque of 3.5 to 5.5 kgf • cm (0.34 N • m to 0.54 N • m).

Installation

■ MOUNTING

Use M4 screws to mount the E3S-C. The tightening torque of each screw must be 12 kgf • m (1.18 N • m) maximum.

■ DIRECT MOUNTING

Mount the E3S-C as shown in the following illustrations.

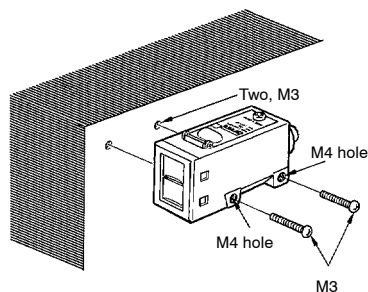
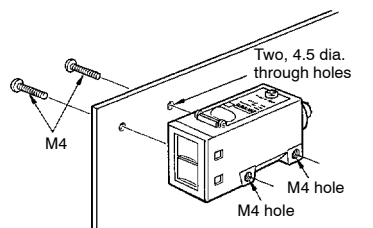

■ OPTICAL AXIS OF THROUGH-BEAM SENSOR

The E3S-C through-beam models incorporate two lenses, one of which will be used as shown in the following illustration. When using a slit, the slit must be on the side where the lens is located.

Lens in use. The slit must be on this side.

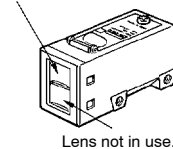

NOTE: DIMENSIONS SHOWN ARE IN MILLIMETERS. To convert millimeters to inches divide by 25.4.

OMRON[®]

OMRON ELECTRONICS LLC

One East Commerce Drive
Schaumburg, IL 60173

1-800-55-OMRON

OMRON ON-LINE

Global - <http://www.omron.com>
USA - <http://www.omron.com/oei>
Canada - <http://www.omron.com/oci>

OMRON CANADA, INC.

885 Milner Avenue
Scarborough, Ontario M1B 5V8

416-286-6465