



This document is the property of and embodies CONFIDENTIAL and PROPRIETARY information of FCI. No part of the information shown on this document may be used in any way or disclosed to others without the written consent of FCI. Copyright FCI.

1 2 3 4

A

B

C

D

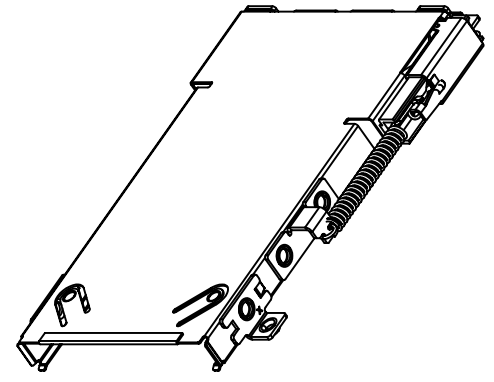
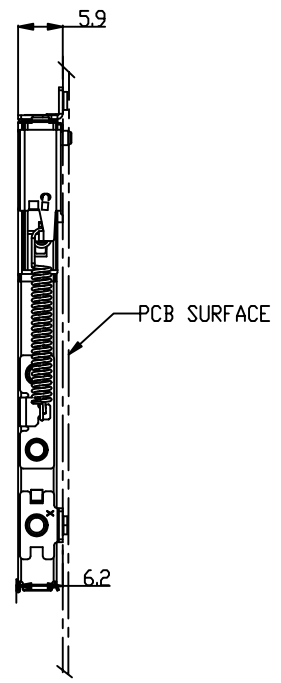
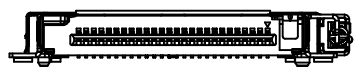
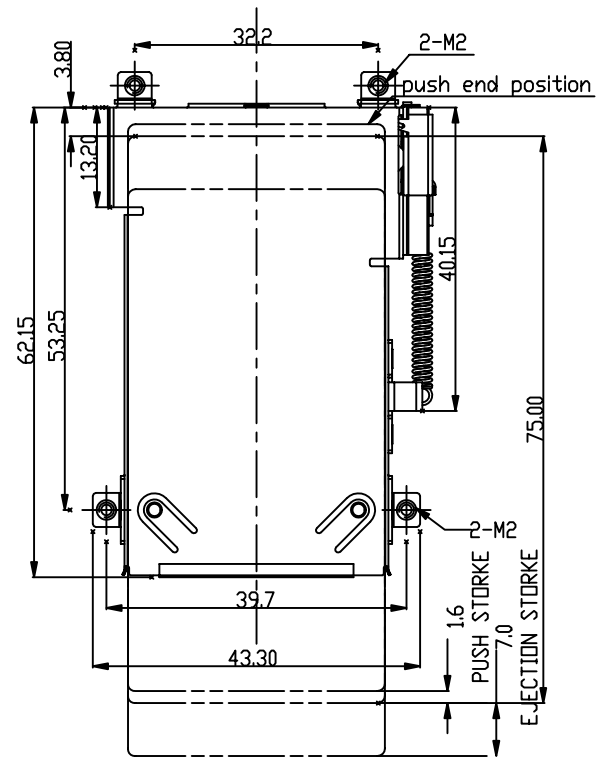

A

B

C

D

TOLERANCES UNLESS OTHERWISE SPECIFIED		
LINEAR	0.XX	±0.5
	0.XXX	±0.3
	0.XXX	±0.050
ANGULAR	0°	±2°

Material		SEE NOTE		Spec ref *	
Mat code				tolerance	projection
Heattreat				✓	⊕
Plating/Finish					↔
Dr	MIAD SH	2007/07/10		size	A4
Eng	MIAD SH	2007/07/10	Product family		Scale
Chr	TAD DANIEL	2007/07/11	Model Name	10073907	1.000
Appr	TAD DANIEL	2007/07/11	Model Revision	1	REL Level prol_release
FCI		title		dwg no	
		BELOW MOUNT, CARD PUSH		10073907	
		EXPRESSCARD HOST MECH.		Rev.	
Pro/E file		catalog no		A	
		10073907		CUSTOMER	
				sheet 1 of 2	

1

2

3

4

PART NO.	MOUNTING	STAND-OFF	HOST CONN P/N	CONN UNMATING FORCE
10073907-00BLF	BELOW	0MM	10065051-X00BXXLF	18.5N MAX.

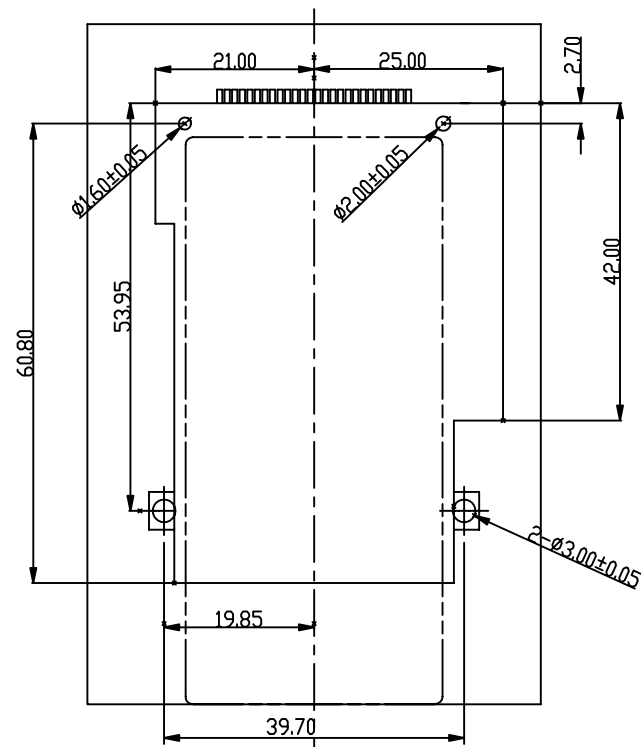

RECOMMENDED PCB LAYOUT  
(VIEW FROM MOUNTING SIDE)

- NOTE:
1. 4M2\*0.4P SCREWS WITH WASHER ARE REQUIRED
  2. SHOW DIMENSION AFTER FASTENED TO PCB.
  3. SEE HOST CONNECTOR DRAWINGS FOR PCB LAYOUT DETAIL.
  4. RECOMMENDED TIGHTING TORQUE 1.6~1.8 KGF-CM.

Material		SEE NOTE		Spec ref *	
Mat code				tolerance	projection
Heattreat				✓	⊕
Plating/Finish				↔	
Dr	MIAO SH	2007/07/10			size A4
Eng	MIAO SH	2007/07/10	Product family		Scale 1.000
Chr	TAD DANIEL	2007/07/11	Model Name 10073907		ECN N07-0157
Appr	TAD DANIEL	2007/07/11	Model Revision 1		REL Levelproi_release
FCI		title BELOW MOUNT, CARD PUSH		dwg no 10073907	
		EXPRESSCARD HOST MECH.		Rev.	
Pro/E file	catalog no	10073907		CUSTOMER	sheet 2 of 2

This document is the property of and embodies CONFIDENTIAL and PROPRIETARY information of FCI. No part of the information shown on this document may be used in any way or disclosed to others without the written consent of FCI. Copyright FCI.