

# NE1617A

## Temperature monitor for microprocessor systems

Rev. 5 — 20 March 2012

Product data sheet

### 1. General description

---

The NE1617A is an accurate two-channel temperature monitor. It measures the temperature of itself and the temperature of a remote sensor. The remote sensor is a diode connected transistor. This can be in the form of either a discrete NPN/PNP, such as the 2N3904/2N3906, or a diode connected PNP built into another die, such as is done on some Intel microprocessors.

The temperature of both the remote and local sensors is stored in a register that can be read via a 2-wire SMBus. The temperatures are updated at a rate that is programmable via the SMBus (the average supply current is dependent upon the update rate — the faster the rate, the higher the current).

In addition to the normal operation, which is to update the temperature at the programmed rate, there is a one-shot mode that will force a temperature update.

There is also an alarm that senses either an overtemperature or undertemperature condition. The trip points for this alarm are also programmable.

The device can have one of nine addresses (determined by two address pins), so there can be up to nine of the NE1617A on the SMBus.

It can also be put in standby mode (in order to save power). This can be done either with software (over the SMBus) or with hardware (using the  $\overline{\text{STBY}}$  pin).

### 2. Features and benefits

---

- Replacement for Maxim MAX1617 and Analog Devices ADM1021
- Monitors local and remote temperature
- Local (on-chip) sensor accuracy:
  - ◆  $\pm 2$  °C at 60 °C to 100 °C
  - ◆  $\pm 3$  °C at -40 °C to 125 °C
- Remote sensor accuracy:
  - ◆  $\pm 3$  °C at 60 °C to 100 °C
  - ◆  $\pm 5$  °C at -40 °C to 125 °C
- No calibration required
- Programmable overtemperature/undertemperature alarm
- SMBus 2-wire serial interface up to 100 kHz
- 3 V to 5.5 V supply range; 5.5 V tolerant
- 70  $\mu\text{A}$  supply current in operating mode
- 3  $\mu\text{A}$  (typical) supply current in standby mode



- ESD protection exceeds 2000 V HBM per JESD22-A114 and 1000 V CDM per JESD22-C101
- Latch-up testing is done to JEDEC standard JESD78, which exceeds 100 mA
- Small 16-lead SSOP (QSOP) package

### 3. Applications

- Desktop computers
- Notebook computers
- Smart battery packs
- Industrial controllers
- Telecommunications equipment

### 4. Ordering information

**Table 1. Ordering information**

$T_{amb} = -40\text{ }^{\circ}\text{C}$  to  $+125\text{ }^{\circ}\text{C}$ .

Type number	Topside mark	Package		Version
		Name	Description	
NE1617ADS	NE1617A	SSOP16 <sup>[1]</sup>	plastic shrink small outline package; 16 leads; body width 3.9 mm; lead pitch 0.635 mm	SOT519-1

[1] Also known as QSOP16.

5. Block diagram

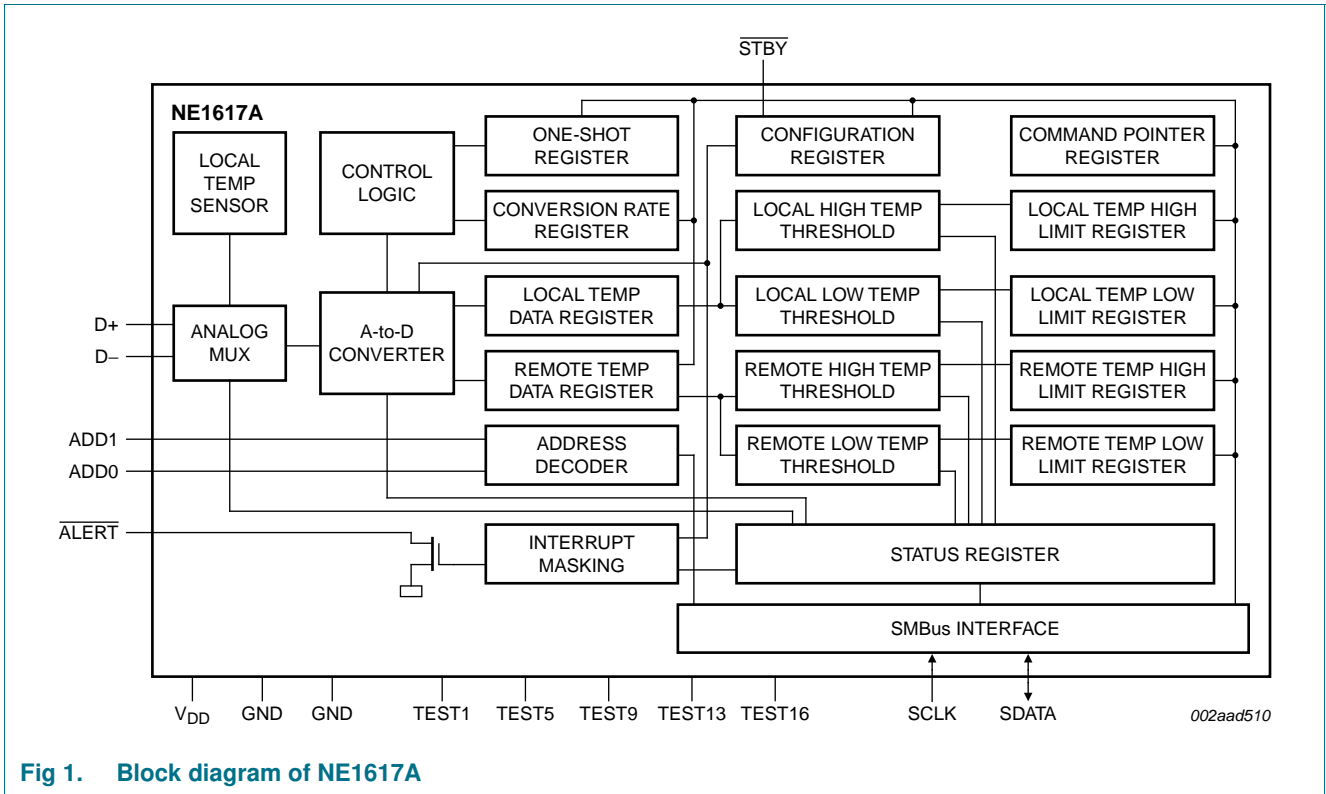

Fig 1. Block diagram of NE1617A

## 6. Pinning information

### 6.1 Pinning

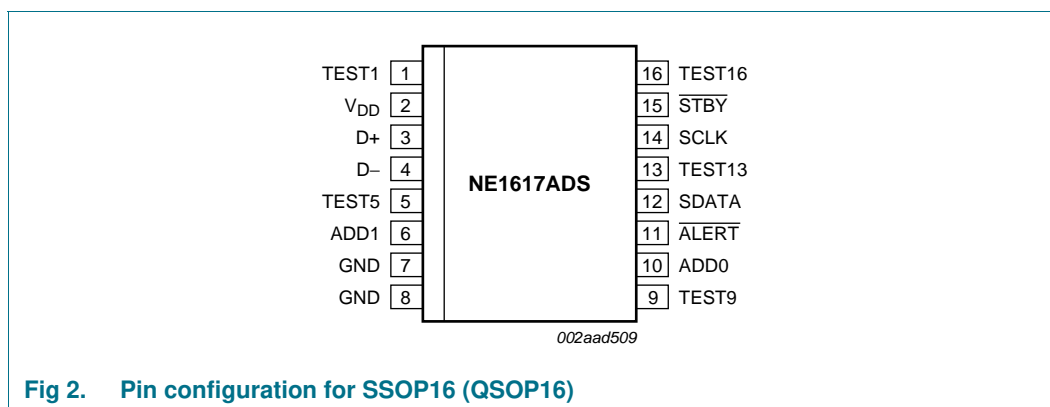

Fig 2. Pin configuration for SSOP16 (QSOP16)

### 6.2 Pin description

Table 2. Pin description

Symbol	Pin	Description
TEST1	1	test pin; factory use only <sup>[1]</sup>
V <sub>DD</sub>	2	positive supply <sup>[2]</sup>
D+	3	positive side of remote sensor
D-	4	negative side of remote sensor
TEST5	5	test pin; factory use only <sup>[1]</sup>
ADD1	6	device address 1 (3-state)
GND	7, 8	ground
TEST9	9	test pin; factory use only <sup>[1]</sup>
ADD0	10	device address 0 (3-state)
$\overline{\text{ALERT}}$	11	open-drain output used as interrupt or SMBus alert
SDATA	12	SMBus serial data input/output; open-drain
TEST13	13	test pin; factory use only <sup>[1]</sup>
SCLK	14	SMBus clock input
$\overline{\text{STBY}}$	15	hardware standby input HIGH = normal operating mode LOW = standby mode
TEST16	16	test pin; factory use only <sup>[1]</sup>

[1] These pins should either float or be tied to ground.

[2] V<sub>DD</sub> pin should be decoupled by a 0.1  $\mu$ F capacitor.

## 7. Functional description

The NE1617A contains an integrating A-to-D converter, an analog multiplexer, a status register, digital data registers, SMBus interface, associated control logic and a local temperature sensor or channel (refer to [Figure 1 “Block diagram of NE1617A”](#)). The remote diode-type sensor or channel should be connected to the D+ and D– pins properly.

Temperature measurements or conversions are either automatically and periodically activated when the device is in free-running mode (both  $\overline{STBY}$  pin = HIGH, and the configuration register bit 6 = LOW) or generated by one-shot command. The free-running period is selected by changing the programmable data of the conversion rate register, as described in [Section 8.3.4](#). For each conversion, the multiplexer switches current sources through the remote and local temperature sensors over a period of time, about 60 ms, and the voltages across the diode-type sensors are sensed and converted into the temperature data by the A-to-D converter. The resulting temperature data is then stored in the temperature registers, in 8-bit two's complement word format and automatically compared with the limits which have been programmed in the temperature limit registers. Results of the comparison are reflected accordingly by the flags stored in the status register, an out-of-limit condition will set the ALERT output pin to its LOW state. Because both channels are automatically measured for each conversion, the results are updated for both channels at the end of every successful conversion.

### 7.1 Temperature measurement

The method of the temperature measurement is based on the change of the diode  $V_{BE}$  at two different operating current levels given by:

$$\Delta V_{BE} = \left( n \times \frac{KT}{q} \right) \times LN(N) \quad (1)$$

where:

$\Delta V_{BE}$  = change in base emitter voltage drop at two current levels

n = non-ideality

K = Boltzman's constant

T = absolute temperature in ° Kelvin

q = charge on the electron

LN = natural logarithm

N = ratio of the two currents

The NE1617A forces two well-controlled current sources of about 10  $\mu$ A and 100  $\mu$ A and measures the remote diode  $V_{BE}$ . The sensed voltage between two pins D+ and D– is limited between 0.25 V and 0.95 V. The external diode must be selected to meet this voltage range at these two current levels and also the non-ideality factor 'n' must be close to the value of 1.008 to be compatible with the Intel Pentium III internal thermal diode that the NE1617A was designed to work with. The diode-connected PNP transistor provided on the microprocessor is typically used, or the discrete diode-connected transistor 2N3904 or 2N3906 is recommended as an alternative.

Even though the NE1617A integrating A-to-D converter has a good noise performance, using the average of 10 measurement cycles, high frequency noise filtering between D+ and D– should be considered. An external capacitor of 2200 pF typical (but not higher than 3300 pF) connected between D+ and D– is recommended. Capacitance higher than 3300 pF will introduce measurement error due to the rise time of the switched current source.

## 7.2 No calibration is required

As mentioned in [Section 7.1](#), the NE1617A uses two well-controlled current sources of 10 : 1 ratio to measure the forward voltage of the diode ( $V_{BE}$ ). This technique eliminates the diode saturation current (a heavily process and temperature dependent variable), and results in the forward voltage being proportional to absolute temperature.

## 7.3 Address logic

The address pins of the NE1617A can be forced into one of three levels: LOW (GND), HIGH ( $V_{DD}$ ), or 'not connected' (n.c.). Because the NE1617A samples and latches the address pins at the starting of every conversion, it is suggested that those address pins should be hard-wired to the logic applied, so that the logic is consistently existed at the address pins. During the address sensing period, the device forces a current at each address pin and compares the voltage developed across the external connection with the predefined threshold voltage in order to define the logic level. If an external resistor is used for the connection of the address, then its value should be less than 2 k $\Omega$  to prevent the error in logic detection from happening. Resistors of 1 k $\Omega$  are recommended.

# 8. Temperature monitor with SMBus serial interface

## 8.1 Serial bus interface

The device can be connected to a standard 2-wire serial interface System Management Bus (SMBus) as a slave device under the control of a master device, using two device terminals SCLK and SDATA. The operation of the device to the bus is described with details in the following sections.

## 8.2 Slave address

The device address is defined by the logical connections applied to the device pins ADD0 and ADD1. A list of selectable addresses are shown in [Table 3](#). The device address can be set to any one of those nine combinations and more than one device can reside on the same bus without address conflict. Note that the state of the device address pins is sampled and latched not only at power-up step, but also at starting point of every conversion.

**Table 3. Device slave address**

*n.c. = not connected*

ADD0 <sup>[1]</sup>	ADD1 <sup>[1]</sup>	Address byte
GND	GND	0011 000
GND	n.c.	0011 001
GND	$V_{DD}$	0011 010
n.c.	GND	0101 001

**Table 3. Device slave address ...continued**

n.c. = not connected

ADD0 <sup>[1]</sup>	ADD1 <sup>[1]</sup>	Address byte
n.c.	n.c.	0101 010
n.c.	V <sub>DD</sub>	0101 011
V <sub>DD</sub>	GND	1001 100
V <sub>DD</sub>	n.c.	1001 101
V <sub>DD</sub>	V <sub>DD</sub>	1001 110

[1] Any pull-up/pull-down resistor used to connect to GND or V<sub>DD</sub> should be ≤ 2 kΩ.

### 8.3 Registers

The device contains more than 9 registers. They are used to store the data of device set-up and operation results. Depending on the bus communication (either read or write operations), each register may be called by different names because each register may have different sub-addresses or commands for read and write operations. For example, the configuration register is called as WC for write mode and as RC for read mode.

[Table 4](#) shows the names, commands and functions of all registers as well as the register POR states.

**Remark:** Attempting to write to a read-command or read from a write-command will produce an invalid result. The reserved registers are used for factory test purposes and should not be written.

**Table 4. Register assignments**

Register name	Command byte	POR state	Function
RIT	00h	0000 0000	read internal or local temp byte
RET	01h	0000 0000	read external or remote temp byte
RS	02h	n/a	read status byte
RC	03h	0000 0000	read configuration byte
RCR	04h	0000 0010	read conversion rate byte
RIHL	05h	0111 1111	read internal temp high limit byte
RILL	06h	1100 1001	read internal temp low limit byte
REHL	07h	0111 1111	read external temp high limit byte
RELL	08h	1100 1001	read external temp low limit byte
WC	09h	n/a	write configuration byte
WCR	0Ah	n/a	write conversion rate byte
WIHL	0Bh	n/a	write internal temp high limit byte
WILL	0Ch	n/a	write internal temp low limit byte
WEHL	0Dh	n/a	write external temp high limit byte
WELL	0Eh	n/a	write external temp low limit byte
OSHT	0Fh	n/a	one-shot command
-	10h	n/a	reserved
-	11h	n/a	reserved
-	12h	n/a	reserved
-	13h	n/a	reserved

### 8.3.1 Low power standby modes

Upon POR, the device is reset to its normal free-running auto-conversion operation mode. The device can be put into standby mode by either using hardware control (connect the  $\overline{\text{STBY}}$  pin to LOW for hardware standby mode) or using software control (set bit 6 of the configuration register to HIGH for software standby mode). When the device is put in either one of the standby modes, the supply current is reduced to less than 10  $\mu\text{A}$  if there is no SMBus activity, all data in the device registers are retained and the SMBus interface is still alive to bus communication. However, there is a difference in the device ADC conversion operation between hardware standby and software standby modes. In hardware standby mode, the device conversion is inhibited and the one-shot command does not initiate a conversion. In software standby mode, the one-shot command will initiate a conversion for both internal and external channels.

If a hardware standby command is received when the device is in normal mode and a conversion is in progress, the conversion cycle will stop and data in reading temperature registers will not be updated.

### 8.3.2 Configuration register

The configuration register is used to mask the Alert interrupt and/or to put the device in software standby mode. Only two bits of this register (bit 6 and bit 7) are used as listed in [Table 5](#). Bit 7 is used to mask the device  $\overline{\text{ALERT}}$  output from Alert interruption when this bit is set to logic 1, and bit 6 is used to activate the standby software mode when this bit is set to logic 1.

This register can be written or read using the commands of registers named WC and RC accordingly. Upon Power-On Reset (POR), both bits are reset to zero.

**Table 5. Configuration register bit assignments**

Bit	Symbol	POR state	Function
7 (MSB)	MASK	0	Mask $\overline{\text{ALERT}}$ interrupt. Interrupt is enabled when this bit is LOW, and disabled when this bit is HIGH.
6	RUN/STOP	0	Standby or run mode control. When LOW, running mode is enabled; when HIGH, standby mode is initiated.
5 to 0	-	n/a	reserved

### 8.3.3 External and internal temperature registers

Results of temperature measurements after every ADC conversion are stored in two registers: Internal Temp register (RIT) for internal or local diode temperature, and External Temp register (RET) for external or remote diode temperature. These registers can be only read over the SMBus. The reading temperature data is in 2's complement binary form consisting of 7-bit data and 1-bit sign (MSB), with each data count represents 1  $^{\circ}\text{C}$ , and the MSB bit is transmitted first over the serial bus. The contents of those two registers are updated upon completion of each ADC conversion. [Table 6](#) shows some values of the temperature and data.



**Table 6. Temperature data format (2's complement)**

Temperature (°C)	Digital output (8 bits)
+127	0111 1111
+126	0111 1110
+100	0110 0100
+50	0011 0010
+25	0001 1001
+1	0000 0001
0	0000 0000
-1	1111 1111
-25	1110 0111
-50	1100 1110
-65	1011 1111

### 8.3.4 Conversion rate register

The conversion rate register is used to store programmable conversion data, which defines the time interval between conversions in standard free-running auto-convert mode. [Table 7](#) shows all applicable data and rates for the device. Only three LSB bits of the register are used and other bits are reserved for future use. This register can be written to and read back over the SMBus using commands of the registers named WCR and RCR, respectively. The POR default conversion data is 02h (0.25 Hz).

Notice that the average supply current, as well as the device power consumption, is increased with the conversion rate.

**Table 7. Conversion rate control byte**

Data	Conversion rate (Hz)	Average supply current ( $\mu$ A typical at $V_{DD} = 3.3$ V)
00h	0.0625	67
01h	0.125	68
02h	0.25	70
03h	0.5	75
04h	1	80
05h	2	95
06h	4	125
07h	8	180
08h to FFh	(reserved)	n/a

### 8.3.5 Temperature limit registers

The device has four registers to be used for storing programmable temperature limits, including the high limit and the low limit for each channel of the external and internal diodes. Data of the temperature register (RIT and RET) for each channel are compared with the contents of the temperature limit registers of the same channel, resulting in alarm conditions. If measured temperature either equals or exceeds the corresponding temperature limits, an Alert interrupt is asserted and the corresponding flag bit in the status register is set. The temperature limit registers can be written to and read back using

commands of registers named WIHL, WILL, WEHL, WELL, RIHL, RILL, REHL, RELL, accordingly. The POR default values are +127 °C (0111 1111) for the HIGH limit and -55 °C (1100 1001) for the LOW limit.

### 8.3.6 One-shot command

The one-shot command is not actually a data register as such and a write operation to it will initiate an ADC conversion. The send byte format of the SMBus, as described later, with the use of OSHT command (0Fh), is used for this writing operation. In normal free-running-conversion operation mode of the device, a one-shot command immediately forces a new conversion cycle to begin. However, if a conversion is in progress when a one-shot command is received, the command is ignored. In software standby mode the one-shot command generates a single conversion and comparison cycle and then puts the device back in its standby mode after the conversion. In hardware standby mode, the one shot is inhibited.

### 8.3.7 Status register

The content of the status register reflects condition status resulting from all of these activities: comparisons between temperature measurements and temperature limits, the status of ADC conversion, and the hardware condition of the connection of external diode to the device. Bit assignments and bit functions of this register are listed in [Table 8](#). This register can only be read using the command of register named RS. Upon POR, the status of all flag bits are reset to zero. The status byte is cleared by any successful read of the status register unless the fault condition persists.

Notice that any one of the fault conditions, except the conversion busy, also introduces an Alert interrupt to the SMBus that will be described in [Section 8.3.8](#). Also, whenever a one-shot command is executed, the status byte should be read after the conversion is completed, which is about 170 ms after the one-shot command is sent.

**Table 8. Status register bit assignment**

Bit	Symbol	POR state	Function
7 (MSB)	BUSY	n/a	HIGH when the ADC is busy converting
6	IHLF <sup>[1]</sup>	0	HIGH when the internal temperature high limit has tripped
5	ILLF <sup>[1]</sup>	0	HIGH when the internal temperature low limit has tripped
4	EHLF <sup>[1]</sup>	0	HIGH when the external temperature high limit has tripped
3	ELLF <sup>[1]</sup>	0	HIGH when the external temperature low limit has tripped
2	OPEN <sup>[2]</sup>	0	HIGH when the external diode is opened
1 to 0	-	0	reserved

[1] These flags stay HIGH until the status register is read or POR is activated.

[2] This flag stays HIGH until POR is activated.

### 8.3.8 Alert interrupt

The  $\overline{\text{ALERT}}$  output is used to signal Alert interruption from the device to the SMBus and is active LOW. Because this output is an open-drain output, a pull-up resistor (10 k $\Omega$  typical) to  $V_{\text{DD}}$  is required, and slave devices can share a common interrupt line on the same SMBus. An Alert interrupt is asserted by the device whenever any one of the fault conditions, as described in [Section 8.3.7 “Status register”](#), occurs: measured temperature equals or exceeds corresponding temp limits, the remote diode is physically disconnected from the device pins. Alert interrupt signal is latched and can only be cleared by reading

the Alert Response byte from the Alert Response Address, which is a special slave address to the SMBus. The  $\overline{\text{ALERT}}$  output cannot be reset by reading the device status register.

The device was designed to accommodate the Alert interrupt detection capability of the SMBus.<sup>1</sup> Basically, the SMBus provides Alert response interrupt pointers in order to identify the slave device which has caused the Alert interrupt. The 7-bit Alert response slave address is 0001 100 and the Alert response byte reflects the slave address of the device which has caused Alert interrupt. Bit assignments of the Alert response byte are listed in Table 9. The  $\overline{\text{ALERT}}$  output will be reset to HIGH state upon reading the Alert response slave address unless the fault condition persists.

**Table 9. Alert response (Alert response address 0001 100) bit description**

Bit	Symbol	Description
7 (MSB)	ADD7	indicate address B6 of alerted device
6	ADD6	indicate address B5 of alerted device
5	ADD5	indicate address B4 of alerted device
4	ADD4	indicate address B3 of alerted device
3	ADD3	indicate address B2 of alerted device
2	ADD2	indicate address B1 of alerted device
1	ADD1	indicate address B0 of alerted device
0 (LSB)	1	logic 1

## 8.4 Power-up default condition

Upon power-up reset (power is switched off-on), the NE1617A goes into this default condition:

- Interrupt latch is cleared, the  $\overline{\text{ALERT}}$  output is pulled HIGH by the external pull-up resistor.
- The auto-conversion rate is at 0.25 Hz; conversion rate data is 02h.
- Temperature limits for both channels are +127 °C for high limit, and –55 °C for low limit.
- Command pointer register is set to '00' for quickly reading the RIT.

## 8.5 Fault detection

The NE1617A has a fault detector to the diode connection. The connection is checked when a conversion is initiated and the proper flags are set if the fault condition has occurred.

**Table 10. Fault detection**

D+ and D–	$\overline{\text{ALERT}}$ output	RET data storage	Status set flag
opened	LOW	127 °C	B2 and B4
shorted	LOW	127 °C	B4

1. The NE1617A implements the collision arbitration function per *System Management Bus Specification Revision 1.1*, dated December 11, 1998, which conforms to standard I<sup>2</sup>C-bus arbitration as described in NXP document *UM10204, "I<sup>2</sup>C-bus specification and user manual"*.

### 8.6 SMBus interface

The device can communicate over a standard 2-wire serial interface System Management Bus (SMBus) using the device pins SCLK and SDATA. The device employs four standard SMBus protocols: write byte, read byte, send byte and receive byte. Data formats of those protocols are shown in [Figure 3](#) with following notifications:

- The SMBus master initiates data transfer by establishing a START condition (S) and terminates data transfer by generating a STOP condition (P).
- Data is sent over the serial bus in sequence of 9 clock pulses according to each 8-bit data byte followed by 1-bit status of the device acknowledgement.
- The 7-bit slave address is equivalent to the selected address of the device.
- The command byte is equivalent to the selected command of the device register.
- The ‘send byte’ format is often used for the one-shot conversion command.
- The ‘receive byte’ format is used for quicker transfer data from a device reading register that was previously selected by a read byte format.

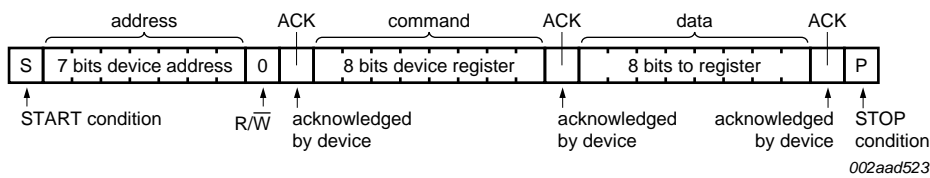

a. Write byte format (for writing data byte to the device register)

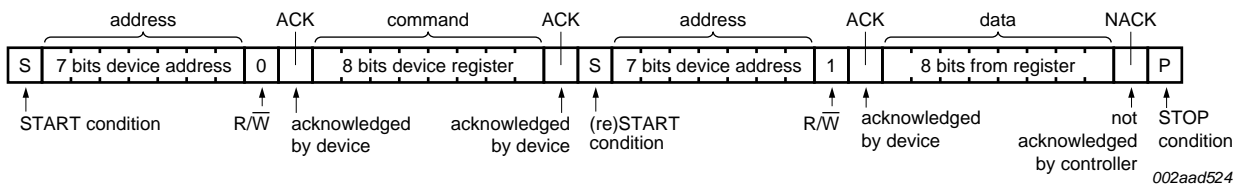

b. Read byte format (for reading data byte from the device register)

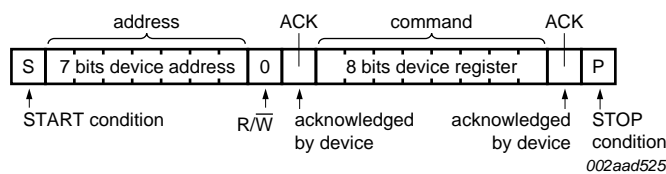

c. Send byte format (for sending command without data, such as one-shot command)

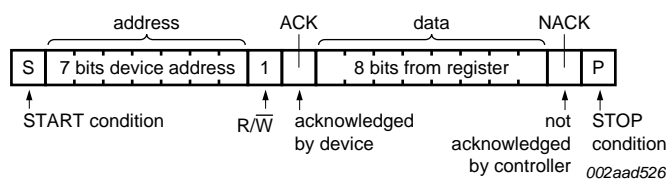

d. Receive byte format (for continuously reading from device register)

Fig 3. SMBus programming format

## 9. Application design-in information

### 9.1 Factors affecting accuracy

#### 9.1.1 Remote sensing diode

The NE1617A is designed to work with substrate transistors built into processors' CPUs or with discrete transistors. Substrate transistors are generally PNP types with the collector connected to the substrate. Discrete types can be either a PNP or an NPN transistor connected as a diode (base shorted to collector). If an NPN transistor is used, the collector and base are connected to D+ and the emitter to D-. If a PNP transistor is used, the collector and base are connected to D- and the emitter to D+. Substrate transistors are found in a number of CPUs. To reduce the error due to variations in these substrate and discrete transistors, a number of factors should be taken into consideration:

- The ideality factor,  $n_f$ , of the transistor. The ideality factor is a measure of the deviation of the thermal diode from the ideal behavior. The NE1617A is trimmed for an  $n_f$  value of 1.008. [Equation 2](#) can be used to calculate the error introduced at a temperature  $T$  °C when using a transistor whose  $n_f$  does not equal 1.008. Consult the processor data sheet for  $n_f$  values.

This value can be written to the offset register and is automatically added to or subtracted from the temperature measurement.

$$\Delta T = \frac{(n_{natural} - 1.008)}{1.008} \times (273.15 \text{ Kelvin} + T) \quad (2)$$

- Some CPU manufacturers specify the high and low current levels of the substrate transistors. The  $I_{source}$  high current level of the NE1617A is 100  $\mu\text{A}$  and the low level current is 10  $\mu\text{A}$ .

If a discrete transistor is being used with the NE1617A, the best accuracy is obtained by choosing devices according to the following criteria:

- Base-emitter voltage greater than 0.25 V at 6 mA, at the highest operating temperature.
- Base-emitter voltage less than 0.95 V at 100 mA, at the lowest operating temperature.
- Base resistance less than 100  $\Omega$ .
- Small variation in  $h_{FE}$  (say 50 to 150) that indicates tight control of  $V_{BE}$  characteristics.

Transistors such as 2N3904, 2N3906, or equivalents in SOT23 packages are suitable devices to use. See [Table 11](#) for representative devices.

Table 11. Representative diodes for temperature sensing

Manufacturer	Model number
Rohm	UMT3904
Diodes Inc.	MMBT3904-7
Philips	MMBT3904
ST Micro	MMBT3904
ON Semiconductor	MMBT3904LT1
Chenmko	MMBT3904
Infineon Technologies	SMBT3904E6327
Fairchild Semiconductor	MMBT3904FSCT
National Semiconductor	MMBT3904N623

### 9.1.2 Thermal inertia and self-heating

Accuracy depends on the temperature of the remote-sensing diode and/or the internal temperature sensor being at the same temperature as that being measured, and a number of factors can affect this. Ideally, the sensor should be in good thermal contact with the part of the system being measured, for example, the processor. If it is not, the thermal inertia caused by the mass of the sensor causes a lag in the response of the sensor to a temperature change. In the case of the remote sensor, this should not be a problem, since it is either a substrate transistor in the processor or a small package device, such as the SOT23, placed in close proximity to it.

The on-chip sensor, however, is often remote from the processor and is only monitoring the general ambient temperature around the package. The thermal time constant of the SSOP16 package in still air is about 140 seconds, and if the ambient air temperature quickly changed by 100 °C, it would take about 12 minutes (five time constants) for the junction temperature of the NE1617A to settle within 1 °C of this. In practice, the NE1617A package is in electrical and therefore thermal contact with a printed-circuit board and can also be in a forced airflow. How accurately the temperature of the board and/or the forced airflow reflect the temperature to be measured also affects the accuracy.

Self-heating due to the power dissipated in the NE1617A or the remote sensor causes the chip temperature of the device or remote sensor to rise above ambient. However, the current forced through the remote sensor is so small that self-heating is negligible. In the case of the NE1617A, the worst-case condition occurs when the device is converting at 16 conversions per second while sinking the maximum current of 1 mA at the  $\overline{\text{ALERT}}$  output. In this case, the total power dissipation in the device is about 11 mW. The thermal resistance,  $R_{th(j-a)}$ , of the SSOP16 package is about 121 °C/W.

In practice, the package has electrical and therefore thermal connection to the printed circuit board, so the temperature rise due to self-heating is negligible.

9.1.3 Layout considerations

Digital boards can be electrically noisy environments, and the NE1617A is measuring very small voltages from the remote sensor, so care must be taken to minimize noise induced at the sensor inputs. The following precautions should be taken.

1. Place the NE1617A as close as possible to the remote sensing diode. Provided that the worst noise sources, that is, clock generators, data/address buses, and CRTs, are avoided, this distance can be four to eight inches.
2. Route the D+ and D- tracks close together, in parallel, with grounded guard tracks on each side. Provide a ground plane under the tracks if possible.
3. Use wide tracks to minimize inductance and reduce noise pickup. 10 mil track minimum width and spacing is recommended (see [Figure 4](#)).
4. Try to minimize the number of copper/solder joints, which can cause thermocouple effects. Where copper/solder joints are used, make sure that they are in both the D+ and D- path and at the same temperature.

Thermocouple effects should not be a major problem since 1 °C corresponds to about 200 μV and thermocouple voltages are about 3 μV/°C of temperature difference. Unless there are two thermocouples with a big temperature differential between them, thermocouple voltages should be much less than 200 μV.

5. Place a 0.1 μF bypass capacitor close to the V<sub>DD</sub> pin. In very noisy environments, place a 1000 pF input filter capacitor across D+ and D- close to the NE1617A.
6. If the distance to the remote sensor is more than eight inches, the use of twisted pair cable is recommended. This works up to about six feet to 12 feet.
7. For really long distances (up to 100 feet), use shielded twisted pair, such as Belden #8451 microphone cable. Connect the twisted pair to D+ and D- and the shield to GND close to the NE1617A. Leave the remote end of the shield unconnected to avoid ground loops.

Because the measurement technique uses switched current sources, excessive cable and/or filter capacitance can affect the measurement. When using long cables, the filter capacitor can be reduced or removed.

Cable resistance can also introduce errors. 1 Ω resistance introduces about 1 °C error.

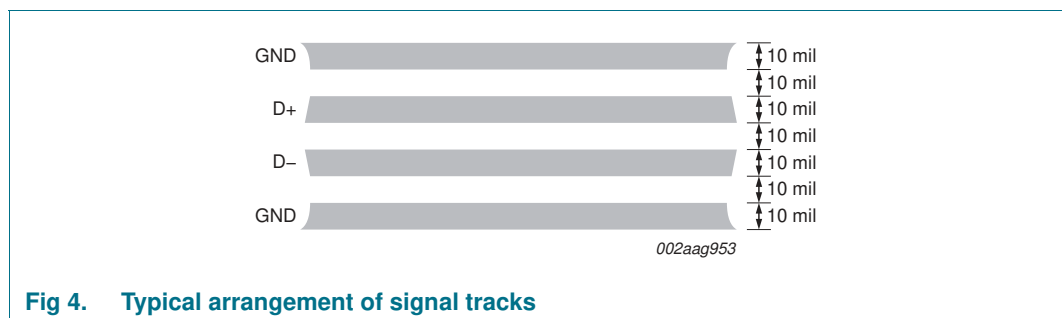

Fig 4. Typical arrangement of signal tracks

9.2 Power sequencing considerations

9.2.1 Power supply slew rate

When powering-up the NE1617A, ensure that the slew rate of  $V_{DD}$  is less than  $18 \text{ mV}/\mu\text{s}$ . A slew rate larger than this may cause power-on reset issues and yield unpredictable results.

9.2.2 Application circuit

Figure 5 shows a typical application circuit for the NE1617A, using a discrete sensor transistor connected via a shielded, twisted pair cable. The pull-ups on SCLK, SDATA, and ALERT are required only if they are not already provided elsewhere in the system.

The SCLK and SDATA pins of the NE1617A can be interfaced directly to the SMBus of an I/O controller, such as the Intel 820 chip set.

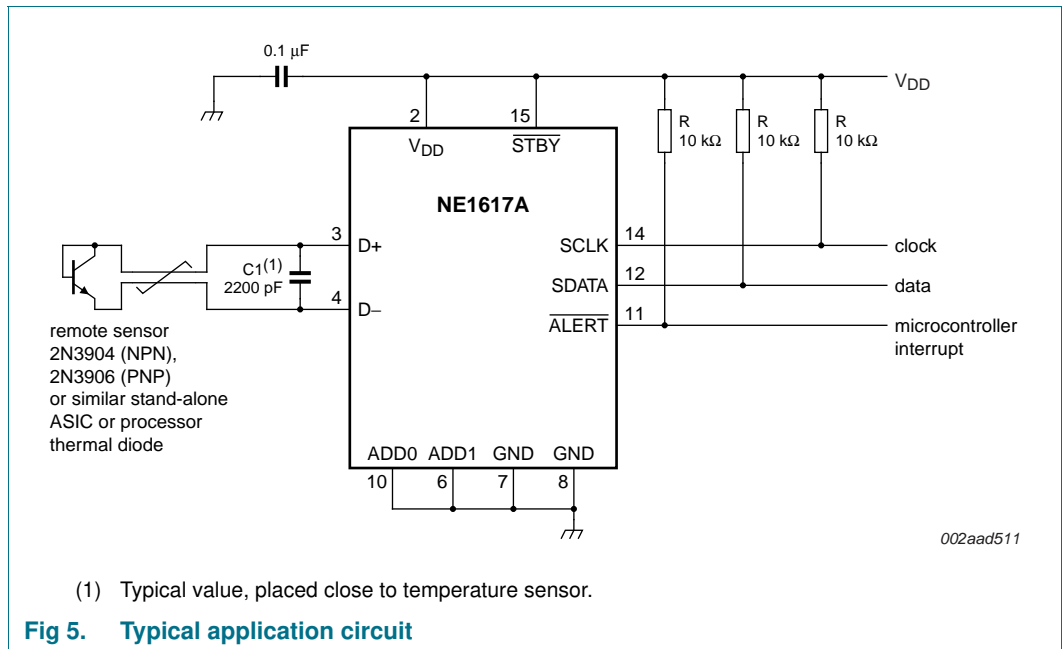



## 10. Limiting values

**Table 12. Limiting values**

*In accordance with the Absolute Maximum Rating System (IEC 60134).*

Symbol	Parameter	Conditions	Min	Max	Unit
$V_{DD}$	supply voltage	$V_{DD}$ to GND	-0.3	+6	V
$V_I$	input voltage	D+, ADD0, ADD1	-0.3	$V_{DD} + 0.3$	V
		D- to GND	-0.3	+0.8	V
		SCLK, SDATA, $\overline{\text{ALERT}}$ , $\overline{\text{STBY}}$	-0.3	+6	V
$I_I$	input current	SDATA	-1	+50	mA
		D-	-	$\pm 1$	mA
$T_{amb}$	ambient temperature	operating	-55	+125	°C
$T_{j(max)}$	maximum junction temperature		-	+150	°C
$T_{stg}$	storage temperature		-65	+150	°C

## 11. Characteristics

**Table 13. Characteristics**

$V_{DD} = 3.0\text{ V to }3.6\text{ V}$ ;  $T_{amb} = 0\text{ °C to }+125\text{ °C}$ ; unless otherwise specified.

Symbol	Parameter	Conditions	Min	Typ	Max	Unit
$T_{res}$	temperature resolution		1	-	-	°C
$T_{acc(loc)}$	local temperature accuracy	$T_{amb} = +60\text{ °C to }+100\text{ °C}$	-	$< \pm 1$	$\pm 2$	°C
		$T_{amb} = 0\text{ °C to }+125\text{ °C}$	-	$< \pm 2$	$\pm 3$	°C
$T_{acc(rem)}$	remote temperature accuracy	$T_{remote} = +60\text{ °C to }+100\text{ °C}$	-	-	$\pm 3$	°C
		$T_{remote} = -40\text{ °C to }+125\text{ °C}$	-	-	$\pm 5$	°C
$V_{th(UVLO)}$	undervoltage lockout threshold voltage <sup>[1]</sup>	$V_{DD}$ supply <sup>[2]</sup>	-	2.7	2.95	V
$V_{th(POR)}$	power-on reset threshold voltage	$V_{DD}$ supply (falling edge) <sup>[3]</sup>	1.0	-	2.5	V
$I_{DD(AV)}$	average supply current	conversion rate = 0.25 per second	-	-	70	μA
		conversion rate = 2 per second	-	-	180	μA
$I_{DD(stb)}$	standby supply current	SMBus inactive	-	3	10	μA
$t_{conv}$	conversion time	from STOP bit to conversion complete; both channels	-	-	170	ms
$E_{f(conv)}$	conversion rate error	percentage error in programmed rate	-30	-	+30	%
$I_{source}$	source current	remote sensor				
		HIGH level	-	100	-	μA
		LOW level	-	10	-	μA
$I_{bias}$	bias current	ADD0, ADD1; momentary as the address is being read	<sup>[4][5]</sup> -	160	-	μA

[1] The value of  $V_{DD}$  below which the internal A/D converter is disabled. This is designed to be a minimum of 200 mV above the power-on reset. During the time that it is disabled, the temperature that is in the 'read temperature registers' will remain at the value that it was before the ADC was disabled. This is done to eliminate the possibility of reading unexpected false temperatures due to the A/D converter not working correctly due to low voltage. In case of power-up (rising  $V_{DD}$ ), the reading that is stored in the 'read temperature registers' will be the default value of 0 °C. As soon as  $V_{DD}$  has risen to the value of UVLO, the ADC will function correctly and normal temperatures will be read.

[2]  $V_{DD}$  (rising edge) voltage below which the ADC is disabled.

[3]  $V_{DD}$  (falling edge) voltage below which the logic is reset.

[4] Address is read at power-up and at start of conversion for all conversions except the fastest rate.

[5] Due to the bias current, any pull-up/pull-down resistors should be  $\leq 2\text{ k}\Omega$ .

**Table 14. Characteristics**

$V_{DD} = 3.3\text{ V}$ ;  $T_{amb} = -40\text{ °C}$  to  $+125\text{ °C}$ ; unless otherwise specified.<sup>[1]</sup>

Symbol	Parameter	Conditions	Min	Typ	Max	Unit
<b>ADC and power supply</b>						
$T_{res}$	temperature resolution	monotonicity guaranteed	[2] 8	-	-	bits
$T_{acc(loc)}$	local temperature accuracy <sup>[3]</sup>	$T_{amb} = +60\text{ °C}$ to $+100\text{ °C}$	-	$< \pm 1$	$\pm 2$	°C
		$T_{amb} = -40\text{ °C}$ to $+125\text{ °C}$	-	$< \pm 2$	$\pm 3$	°C
$T_{acc(rem)}$	remote temperature accuracy <sup>[3]</sup>	$T_{remote} = +60\text{ °C}$ to $+100\text{ °C}$	[4] -	-	$\pm 3$	°C
		$T_{remote} = -40\text{ °C}$ to $+125\text{ °C}$	[4] -	-	$\pm 5$	°C
$V_{DD}$	supply voltage		3.0	-	5.5	V
$t_{conv}$	conversion time	from STOP bit to conversion complete; both channels	-	125	156	ms
$E_{f(conv)}$	conversion rate error	percentage error in programmed rate	-25	-	+25	%
<b>SMBus interface</b>						
$V_{IH}$	HIGH-level input voltage	$\overline{STBY}$ , SCLK, SDATA				
		$V_{DD} = 3\text{ V}$	2.2	-	-	V
		$V_{DD} = 5.5\text{ V}$	2.4	-	-	V
$V_{IL}$	LOW-level input voltage	$\overline{STBY}$ , SCLK, SDATA; $V_{DD} = 3\text{ V}$ to $5.5\text{ V}$	-	-	0.8	V
$I_{sink}$	sink current	logic output LOW; ALERT, SDATA forced to 0.4 V	6	-	-	mA
$I_{LOH}$	HIGH-level output leakage current	ALERT; forced to 5.5 V	-	-	1	μA
$I_I$	input current	logic inputs forced to $V_{DD}$ or GND	-2	-	+2	μA

[1] Specifications from  $-40\text{ °C}$  to  $+125\text{ °C}$  are guaranteed by design, not production tested.

[2] Guaranteed but not 100 % tested.

[3] Quantization error is not included in specifications for temperature accuracy. For example, if the NE1617A device temperature is exactly  $+66.7\text{ °C}$ , the ADC may report  $+66\text{ °C}$ ,  $+67\text{ °C}$  or  $+68\text{ °C}$  (due to the quantization error plus the  $-0.5\text{ °C}$  offset used for rounding up) and still be within the guaranteed  $\pm 1\text{ °C}$  error limits for the  $+60\text{ °C}$  to  $+100\text{ °C}$  temperature range.

[4]  $T_{remote}$  is the junction temperature of the remote diode. See [Section 7.1 "Temperature measurement"](#) for remote diode forward voltage requirements.

**Table 15. SMBus interface dynamic characteristics**<sup>[1]</sup>

$V_{DD} = 3.0\text{ V to }3.6\text{ V}$ ;  $T_{amb} = 0\text{ }^{\circ}\text{C to }+125\text{ }^{\circ}\text{C}$ ; unless otherwise specified.<sup>[2]</sup>

Symbol	Parameter	Conditions	Min	Typ	Max	Unit
$V_{IH}$	HIGH-level input voltage	$\overline{\text{STBY}}$ , SCLK, SDATA	2.2	-	-	V
$V_{IL}$	LOW-level input voltage	$\overline{\text{STBY}}$ , SCLK, SDATA	-	-	0.8	V
$I_{OL}$	logic output LOW sink current	$\overline{\text{ALERT}}$ ; $V_{OL} = 0.4\text{ V}$	1.0	-	-	mA
		SDATA; $V_{OL} = 0.6\text{ V}$	6.0	-	-	mA
$I_{IH}$	HIGH-level input current	$V_i = V_{DD}$	-1	-	+1	$\mu\text{A}$
$I_{IL}$	LOW-level input current	$V_i = \text{GND}$	-1	-	+1	$\mu\text{A}$
$C_i$	input capacitance	SCLK, SDATA	-	5	-	pF
$f_{\text{SCLK}}$	SCLK operating frequency		0	-	100	kHz
$t_{\text{LOW}}$	SCLK LOW time		4.7	5.0	-	$\mu\text{s}$
$t_{\text{HIGH}}$	SCLK HIGH time		4.0	5.0	-	$\mu\text{s}$
$t_{\text{BUF}}$	bus free time between a STOP and START condition	from SDATA STOP to SDATA START	4.7	-	-	$\mu\text{s}$
$t_{\text{HD,STA}}$	hold time (repeated) START condition	from SDATA START to first SCLK HIGH-to-LOW transition	4.0	-	-	$\mu\text{s}$
$t_{\text{HD,DAT}}$	data hold time	from SCLK HIGH-to-LOW transition to SDATA edges	0	-	-	ns
$t_{\text{SU,DAT}}$	data set-up time	from SDATA edges to SCLK LOW-to-HIGH transition	250	-	-	ns
$t_{\text{SU,STA}}$	set-up time for a repeated START condition	from SCLK LOW-to-HIGH transition to restart SDATA	250	-	-	ns
$t_{\text{SU,STO}}$	set-up time for STOP condition	from SCLK LOW-to-HIGH transition to SDATA STOP condition	4.0	-	-	$\mu\text{s}$
$t_f$	fall time	SCLK and SDATA signals	-	-	1.0	$\mu\text{s}$

[1] The NE1617A does not include the SMBus time-out capability ( $t_{\text{LOW,SEXT}}$  and  $t_{\text{LOW,MEXT}}$ ).

[2] Device operation between 3.0 V and 5.5 V is allowed, but parameters may be outside the limit shown in this table.

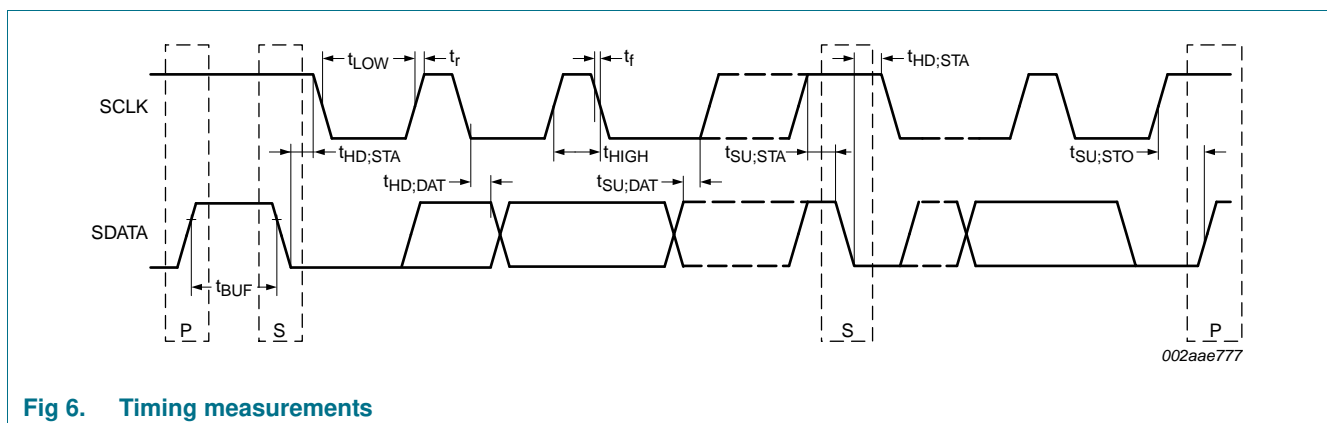

**Fig 6. Timing measurements**

11.1 Typical performance curves

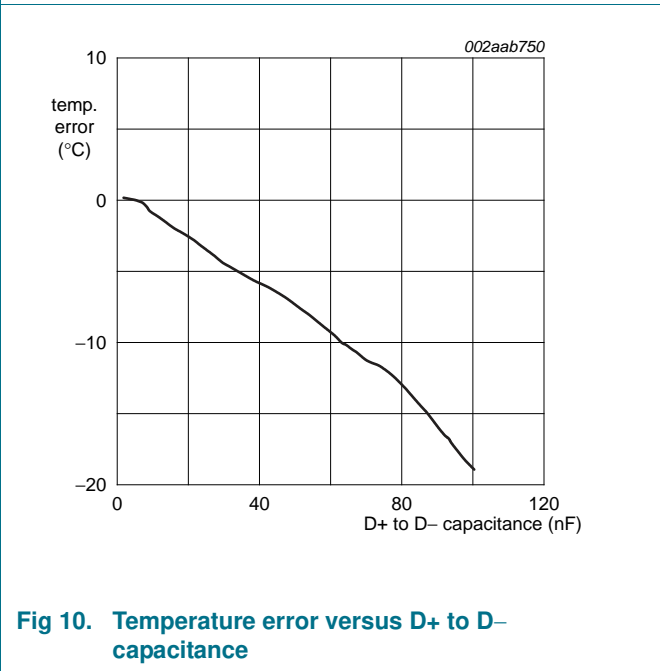
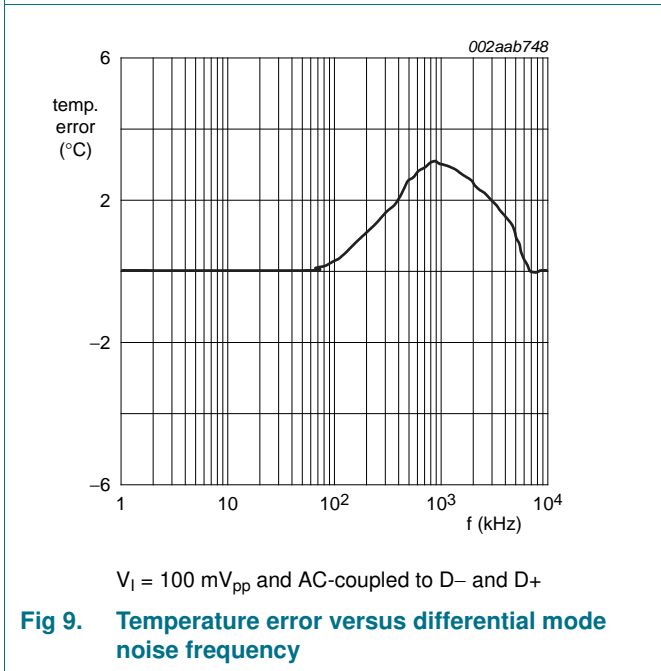
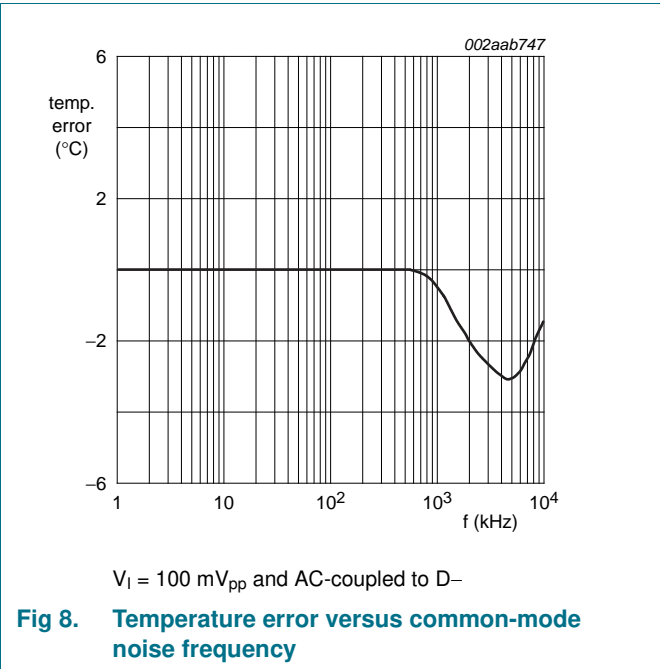
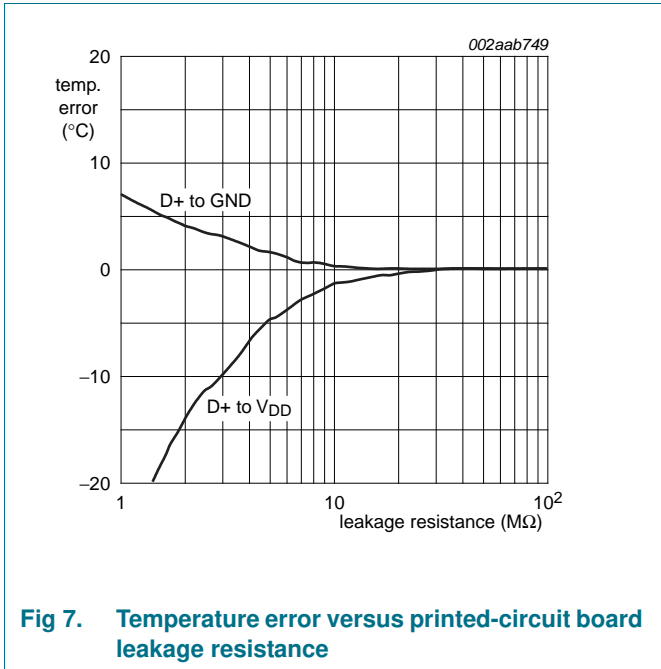

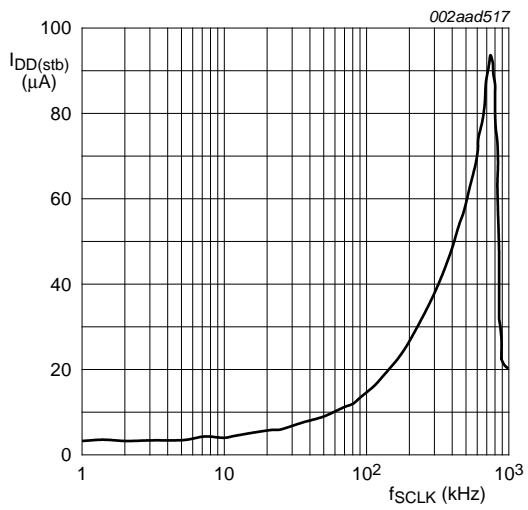

Fig 11. Standby supply current versus clock frequency at  $V_{DD} = 3.3 V$

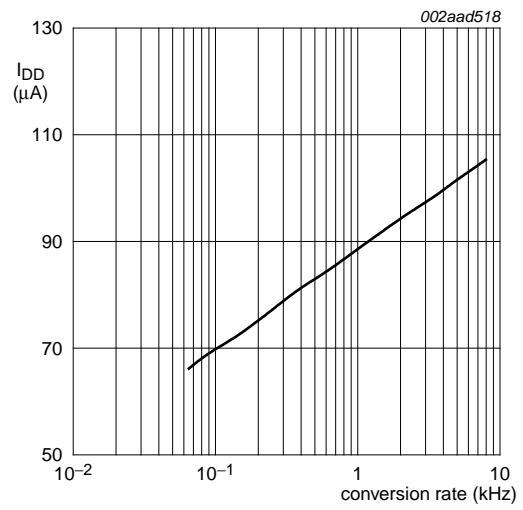

Fig 12. Operating supply current versus conversion rate at  $V_{DD} = 3.3 V$

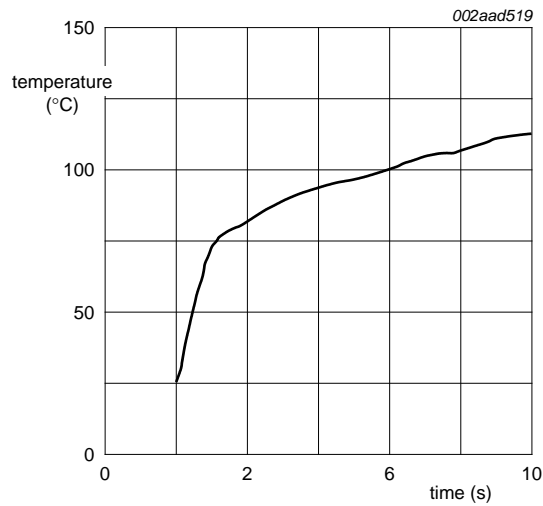

Fig 13. Response to thermal shock immersed in +115  $^{\circ}C$  fluorinert bath

## 12. Package outline

SSOP16: plastic shrink small outline package; 16 leads; body width 3.9 mm; lead pitch 0.635 mm SOT519-1

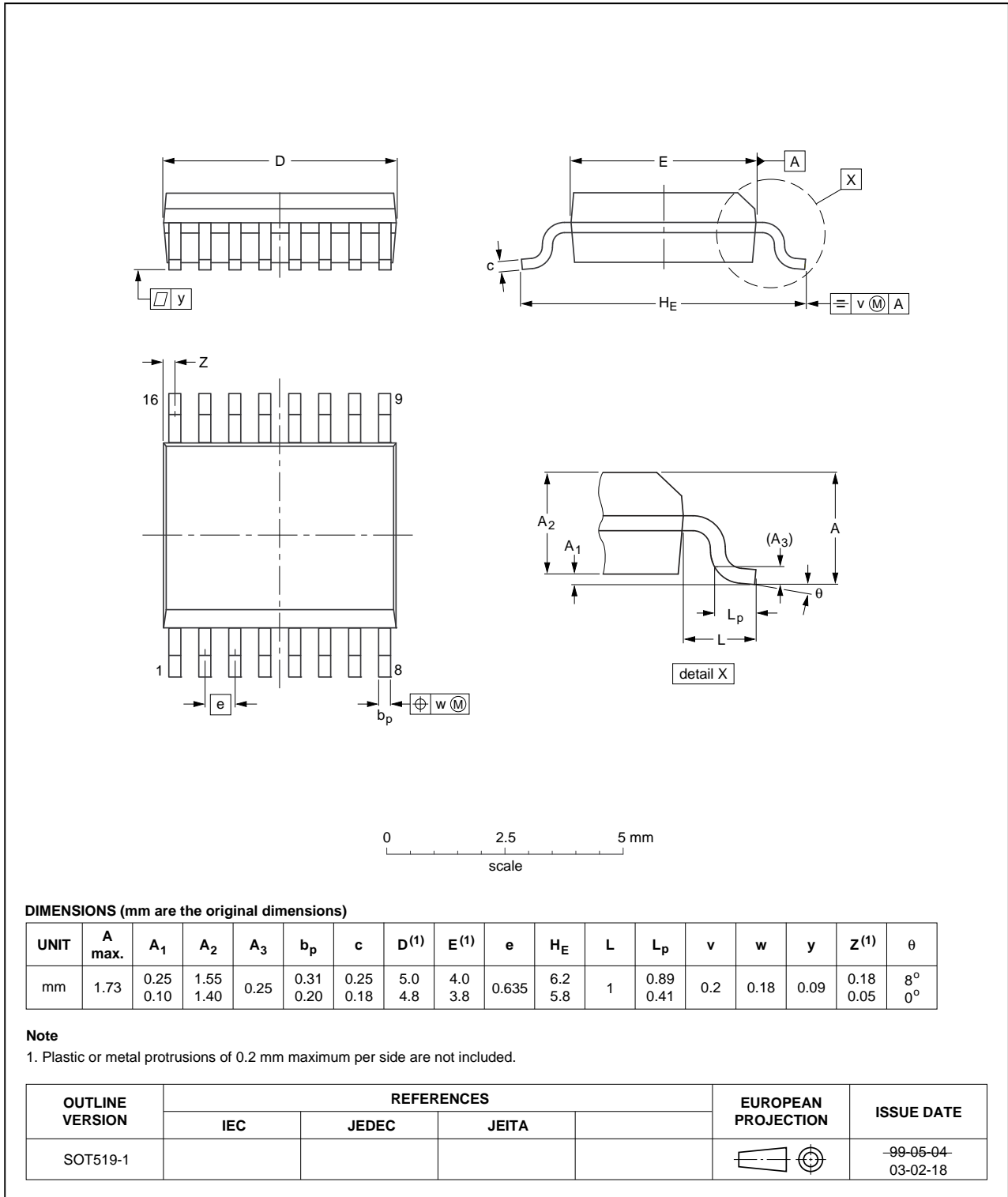

Fig 14. Package outline SOT519-1 (SSOP16)

## 13. Soldering of SMD packages

This text provides a very brief insight into a complex technology. A more in-depth account of soldering ICs can be found in Application Note *AN10365 "Surface mount reflow soldering description"*.

### 13.1 Introduction to soldering

Soldering is one of the most common methods through which packages are attached to Printed Circuit Boards (PCBs), to form electrical circuits. The soldered joint provides both the mechanical and the electrical connection. There is no single soldering method that is ideal for all IC packages. Wave soldering is often preferred when through-hole and Surface Mount Devices (SMDs) are mixed on one printed wiring board; however, it is not suitable for fine pitch SMDs. Reflow soldering is ideal for the small pitches and high densities that come with increased miniaturization.

### 13.2 Wave and reflow soldering

Wave soldering is a joining technology in which the joints are made by solder coming from a standing wave of liquid solder. The wave soldering process is suitable for the following:

- Through-hole components
- Leaded or leadless SMDs, which are glued to the surface of the printed circuit board

Not all SMDs can be wave soldered. Packages with solder balls, and some leadless packages which have solder lands underneath the body, cannot be wave soldered. Also, leaded SMDs with leads having a pitch smaller than ~0.6 mm cannot be wave soldered, due to an increased probability of bridging.

The reflow soldering process involves applying solder paste to a board, followed by component placement and exposure to a temperature profile. Leaded packages, packages with solder balls, and leadless packages are all reflow solderable.

Key characteristics in both wave and reflow soldering are:

- Board specifications, including the board finish, solder masks and vias
- Package footprints, including solder thieves and orientation
- The moisture sensitivity level of the packages
- Package placement
- Inspection and repair
- Lead-free soldering versus SnPb soldering

### 13.3 Wave soldering

Key characteristics in wave soldering are:

- Process issues, such as application of adhesive and flux, clinching of leads, board transport, the solder wave parameters, and the time during which components are exposed to the wave
- Solder bath specifications, including temperature and impurities



### 13.4 Reflow soldering

Key characteristics in reflow soldering are:

- Lead-free versus SnPb soldering; note that a lead-free reflow process usually leads to higher minimum peak temperatures (see [Figure 15](#)) than a SnPb process, thus reducing the process window
- Solder paste printing issues including smearing, release, and adjusting the process window for a mix of large and small components on one board
- Reflow temperature profile; this profile includes preheat, reflow (in which the board is heated to the peak temperature) and cooling down. It is imperative that the peak temperature is high enough for the solder to make reliable solder joints (a solder paste characteristic). In addition, the peak temperature must be low enough that the packages and/or boards are not damaged. The peak temperature of the package depends on package thickness and volume and is classified in accordance with [Table 16](#) and [17](#)

**Table 16. SnPb eutectic process (from J-STD-020C)**

Package thickness (mm)	Package reflow temperature (°C)	
	Volume (mm <sup>3</sup> )	
	< 350	≥ 350
< 2.5	235	220
≥ 2.5	220	220

**Table 17. Lead-free process (from J-STD-020C)**

Package thickness (mm)	Package reflow temperature (°C)		
	Volume (mm <sup>3</sup> )		
	< 350	350 to 2000	> 2000
< 1.6	260	260	260
1.6 to 2.5	260	250	245
> 2.5	250	245	245

Moisture sensitivity precautions, as indicated on the packing, must be respected at all times.

Studies have shown that small packages reach higher temperatures during reflow soldering, see [Figure 15](#).

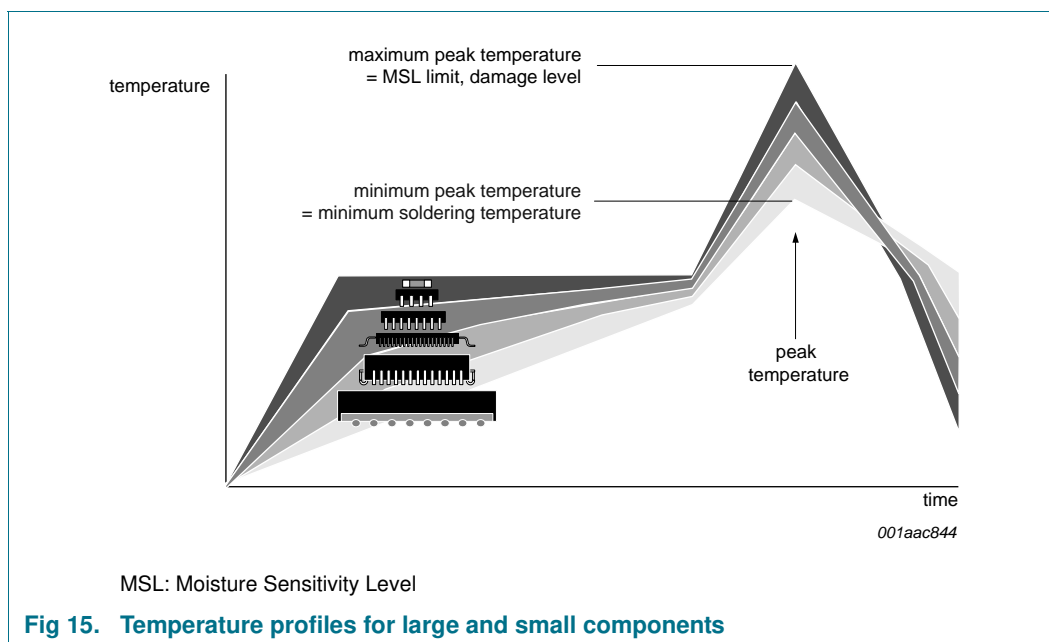

For further information on temperature profiles, refer to Application Note *AN10365* "Surface mount reflow soldering description".

## 14. Abbreviations

**Table 18. Abbreviations**

Acronym	Description
A/D	Analog-to-Digital
ADC	Analog-to-Digital Converter
CDM	Charged-Device Model
CPU	Central Processing Unit
CRT	Cathode Ray Tube
ESD	ElectroStatic Discharge
HBM	Human Body Model
LSB	Least Significant Bit
MM	Machine Model
MSB	Most Significant Bit
NPN	bipolar transistor with N-type emitter and collector and a P-type base
PCB	Printed-Circuit Board
PNP	bipolar transistor with P-type emitter and collector and an N-type base
POR	Power-On Reset
SMBus	System Management Bus
UVLO	UnderVoltage LockOut

## 15. Revision history

Table 19. Revision history

Document ID	Release date	Data sheet status	Change notice	Supersedes
NE1617A v.5	20120320	Product data sheet	-	NE1617A v.4
Modifications:	<ul style="list-style-type: none"> <li>• <a href="#">Section 2 “Features and benefits”</a>, 11th bullet item: deleted phrase “250 V MM per JESD22-A115”</li> <li>• <a href="#">Section 7.1 “Temperature measurement”</a>: <ul style="list-style-type: none"> <li>– section is renamed from “Section 7.1 “Remote diode selection”</li> <li>– updated <a href="#">Equation 1</a></li> <li>– added definition of ‘n’, non-ideality</li> <li>– third paragraph: appended “and also the non-ideality factor ‘n’ must be close to the value of 1.008 to be compatible with the Intel Pentium III internal thermal diode that the NE1617A was designed to work with” to end of third sentence.</li> </ul> </li> <li>• Section 9.1 “How do D+, D- work?” deleted.</li> <li>• Section 9.2 “What is the difference using diode and transistor?” deleted.</li> <li>• Section 9.3 “How is error reduced when necessary to use a wire instead of the PCB trace?” deleted.</li> <li>• <a href="#">Section 9 “Application design-in information”</a> is re-written.</li> <li>• Section 14 “Mounting” deleted.</li> </ul>			
NE1617A v.4	20090730	Product data sheet	-	NE1617A v.3
NE1617A v.3 (9397 750 14162)	20041005	Product data sheet	-	NE1617A v.2
NE1617A v.2 (9397 750 09273)	20011214	Product specification	ECN 853-2203 27461 of 14 Dec 2001	NE1617A v.1
NE1617A v.1 (9397 750 07322)	20000713	Product specification	ECN 853-2203 24123 of 13 Jul 2000	-

## 16. Legal information

### 16.1 Data sheet status

Document status <sup>[1][2]</sup>	Product status <sup>[3]</sup>	Definition
Objective [short] data sheet	Development	This document contains data from the objective specification for product development.
Preliminary [short] data sheet	Qualification	This document contains data from the preliminary specification.
Product [short] data sheet	Production	This document contains the product specification.

[1] Please consult the most recently issued document before initiating or completing a design.

[2] The term 'short data sheet' is explained in section "Definitions".

[3] The product status of device(s) described in this document may have changed since this document was published and may differ in case of multiple devices. The latest product status information is available on the Internet at URL <http://www.nxp.com>.

### 16.2 Definitions

**Draft** — The document is a draft version only. The content is still under internal review and subject to formal approval, which may result in modifications or additions. NXP Semiconductors does not give any representations or warranties as to the accuracy or completeness of information included herein and shall have no liability for the consequences of use of such information.

**Short data sheet** — A short data sheet is an extract from a full data sheet with the same product type number(s) and title. A short data sheet is intended for quick reference only and should not be relied upon to contain detailed and full information. For detailed and full information see the relevant full data sheet, which is available on request via the local NXP Semiconductors sales office. In case of any inconsistency or conflict with the short data sheet, the full data sheet shall prevail.

**Product specification** — The information and data provided in a Product data sheet shall define the specification of the product as agreed between NXP Semiconductors and its customer, unless NXP Semiconductors and customer have explicitly agreed otherwise in writing. In no event however, shall an agreement be valid in which the NXP Semiconductors product is deemed to offer functions and qualities beyond those described in the Product data sheet.

### 16.3 Disclaimers

**Limited warranty and liability** — Information in this document is believed to be accurate and reliable. However, NXP Semiconductors does not give any representations or warranties, expressed or implied, as to the accuracy or completeness of such information and shall have no liability for the consequences of use of such information. NXP Semiconductors takes no responsibility for the content in this document if provided by an information source outside of NXP Semiconductors.

In no event shall NXP Semiconductors be liable for any indirect, incidental, punitive, special or consequential damages (including - without limitation - lost profits, lost savings, business interruption, costs related to the removal or replacement of any products or rework charges) whether or not such damages are based on tort (including negligence), warranty, breach of contract or any other legal theory.

Notwithstanding any damages that customer might incur for any reason whatsoever, NXP Semiconductors' aggregate and cumulative liability towards customer for the products described herein shall be limited in accordance with the *Terms and conditions of commercial sale* of NXP Semiconductors.

**Right to make changes** — NXP Semiconductors reserves the right to make changes to information published in this document, including without limitation specifications and product descriptions, at any time and without notice. This document supersedes and replaces all information supplied prior to the publication hereof.

**Suitability for use** — NXP Semiconductors products are not designed, authorized or warranted to be suitable for use in life support, life-critical or safety-critical systems or equipment, nor in applications where failure or malfunction of an NXP Semiconductors product can reasonably be expected to result in personal injury, death or severe property or environmental damage. NXP Semiconductors and its suppliers accept no liability for inclusion and/or use of NXP Semiconductors products in such equipment or applications and therefore such inclusion and/or use is at the customer's own risk.

**Applications** — Applications that are described herein for any of these products are for illustrative purposes only. NXP Semiconductors makes no representation or warranty that such applications will be suitable for the specified use without further testing or modification.

Customers are responsible for the design and operation of their applications and products using NXP Semiconductors products, and NXP Semiconductors accepts no liability for any assistance with applications or customer product design. It is customer's sole responsibility to determine whether the NXP Semiconductors product is suitable and fit for the customer's applications and products planned, as well as for the planned application and use of customer's third party customer(s). Customers should provide appropriate design and operating safeguards to minimize the risks associated with their applications and products.

NXP Semiconductors does not accept any liability related to any default, damage, costs or problem which is based on any weakness or default in the customer's applications or products, or the application or use by customer's third party customer(s). Customer is responsible for doing all necessary testing for the customer's applications and products using NXP Semiconductors products in order to avoid a default of the applications and the products or of the application or use by customer's third party customer(s). NXP does not accept any liability in this respect.

**Limiting values** — Stress above one or more limiting values (as defined in the Absolute Maximum Ratings System of IEC 60134) will cause permanent damage to the device. Limiting values are stress ratings only and (proper) operation of the device at these or any other conditions above those given in the Recommended operating conditions section (if present) or the Characteristics sections of this document is not warranted. Constant or repeated exposure to limiting values will permanently and irreversibly affect the quality and reliability of the device.

**Terms and conditions of commercial sale** — NXP Semiconductors products are sold subject to the general terms and conditions of commercial sale, as published at <http://www.nxp.com/profile/terms>, unless otherwise agreed in a valid written individual agreement. In case an individual agreement is concluded only the terms and conditions of the respective agreement shall apply. NXP Semiconductors hereby expressly objects to applying the customer's general terms and conditions with regard to the purchase of NXP Semiconductors products by customer.

**No offer to sell or license** — Nothing in this document may be interpreted or construed as an offer to sell products that is open for acceptance or the grant, conveyance or implication of any license under any copyrights, patents or other industrial or intellectual property rights.

**Export control** — This document as well as the item(s) described herein may be subject to export control regulations. Export might require a prior authorization from competent authorities.

**Non-automotive qualified products** — Unless this data sheet expressly states that this specific NXP Semiconductors product is automotive qualified, the product is not suitable for automotive use. It is neither qualified nor tested in accordance with automotive testing or application requirements. NXP Semiconductors accepts no liability for inclusion and/or use of non-automotive qualified products in automotive equipment or applications.

In the event that customer uses the product for design-in and use in automotive applications to automotive specifications and standards, customer (a) shall use the product without NXP Semiconductors' warranty of the product for such automotive applications, use and specifications, and (b) whenever customer uses the product for automotive applications beyond

NXP Semiconductors' specifications such use shall be solely at customer's own risk, and (c) customer fully indemnifies NXP Semiconductors for any liability, damages or failed product claims resulting from customer design and use of the product for automotive applications beyond NXP Semiconductors' standard warranty and NXP Semiconductors' product specifications.

**Translations** — A non-English (translated) version of a document is for reference only. The English version shall prevail in case of any discrepancy between the translated and English versions.

## 16.4 Trademarks

Notice: All referenced brands, product names, service names and trademarks are the property of their respective owners.

## 17. Contact information

For more information, please visit: <http://www.nxp.com>

For sales office addresses, please send an email to: [salesaddresses@nxp.com](mailto:salesaddresses@nxp.com)

18. Contents

<b>1</b>	<b>General description</b> .....	<b>1</b>	<b>14</b>	<b>Abbreviations</b> .....	<b>26</b>
<b>2</b>	<b>Features and benefits</b> .....	<b>1</b>	<b>15</b>	<b>Revision history</b> .....	<b>27</b>
<b>3</b>	<b>Applications</b> .....	<b>2</b>	<b>16</b>	<b>Legal information</b> .....	<b>28</b>
<b>4</b>	<b>Ordering information</b> .....	<b>2</b>	16.1	Data sheet status .....	28
<b>5</b>	<b>Block diagram</b> .....	<b>3</b>	16.2	Definitions .....	28
<b>6</b>	<b>Pinning information</b> .....	<b>4</b>	16.3	Disclaimers .....	28
6.1	Pinning .....	4	16.4	Trademarks .....	29
6.2	Pin description .....	4	<b>17</b>	<b>Contact information</b> .....	<b>29</b>
<b>7</b>	<b>Functional description</b> .....	<b>5</b>	<b>18</b>	<b>Contents</b> .....	<b>30</b>
7.1	Temperature measurement .....	5			
7.2	No calibration is required .....	6			
7.3	Address logic .....	6			
<b>8</b>	<b>Temperature monitor with SMBus serial interface</b> .....	<b>6</b>			
8.1	Serial bus interface .....	6			
8.2	Slave address .....	6			
8.3	Registers .....	7			
8.3.1	Low power standby modes .....	8			
8.3.2	Configuration register .....	8			
8.3.3	External and internal temperature registers .....	8			
8.3.4	Conversion rate register .....	9			
8.3.5	Temperature limit registers .....	9			
8.3.6	One-shot command .....	10			
8.3.7	Status register .....	10			
8.3.8	Alert interrupt .....	10			
8.4	Power-up default condition .....	11			
8.5	Fault detection .....	11			
8.6	SMBus interface .....	12			
<b>9</b>	<b>Application design-in information</b> .....	<b>13</b>			
9.1	Factors affecting accuracy .....	13			
9.1.1	Remote sensing diode .....	13			
9.1.2	Thermal inertia and self-heating .....	14			
9.1.3	Layout considerations .....	15			
9.2	Power sequencing considerations .....	16			
9.2.1	Power supply slew rate .....	16			
9.2.2	Application circuit .....	16			
<b>10</b>	<b>Limiting values</b> .....	<b>17</b>			
<b>11</b>	<b>Characteristics</b> .....	<b>18</b>			
11.1	Typical performance curves .....	21			
<b>12</b>	<b>Package outline</b> .....	<b>23</b>			
<b>13</b>	<b>Soldering of SMD packages</b> .....	<b>24</b>			
13.1	Introduction to soldering .....	24			
13.2	Wave and reflow soldering .....	24			
13.3	Wave soldering .....	24			
13.4	Reflow soldering .....	25			

Please be aware that important notices concerning this document and the product(s) described herein, have been included in section 'Legal information'.

© NXP B.V. 2012.

All rights reserved.

For more information, please visit: <http://www.nxp.com>

For sales office addresses, please send an email to: [salesaddresses@nxp.com](mailto:salesaddresses@nxp.com)

Date of release: 20 March 2012

Document identifier: NE1617A