

**NOTES:**

1. METALSHELLS: STEEL; min. 315µm TIN over 40-80µm NICKEL
2. INSULATORS: PBT GF UL 94 V-0; GREEN
3. SIGNAL CONTACTS: COPPER ALLOY  
PLATING: GOLD FLASH over NICKEL
4. NO CONTACTS ON POS. A1 - A4
5. METAL BRACKETS:  
STEEL; min. 320µm TIN over 80µm NICKEL
6. THREADED INSERTS: COPPER ALLOY; min. 200µm TIN over 80µm NICKEL
7. P.C.B. HOLE DRILLINGS ON SHEET 2
8. MAXIMUM TORQUE VALUE FOR THREAD: 6 in.LB
9. CONNECTOR IS PART MARKED: 3036W4PAT99N20X CONEC ABC

Directive 2002/95/EC RoHS compliant

THIS DRAWING MAY NOT BE COPIED OR REPRODUCED IN ANY WAY, AND MAY NOT BE PASSED ON TO A THIRD PARTY WITHOUT WRITTEN PERMISSION. OWNERSHIP AND COPYRIGHT OF CONEC GmbH DO NOT ALTER CAD DRAWING BY HAND	tolerance		dim. in mm	scale: 2:1 (5:1)		
				material: see notes		
	drawn	12.02.13	Henneboel	title: <b>D-SUB COMBINATION MALE 90°</b> 36W4P with threaded insert and metal bracket		
	appd.	12.02.13	Koch			
	norm					
	d-old					
	a	Original		dwg no: 13K1A4179		DIN-A3
	rev.	description	date	part no: 3036W4PAT99N20X		sh: 1/2

# P.C.B. HOLE DRILLINGS

( P.C.B. TOP SIDE )

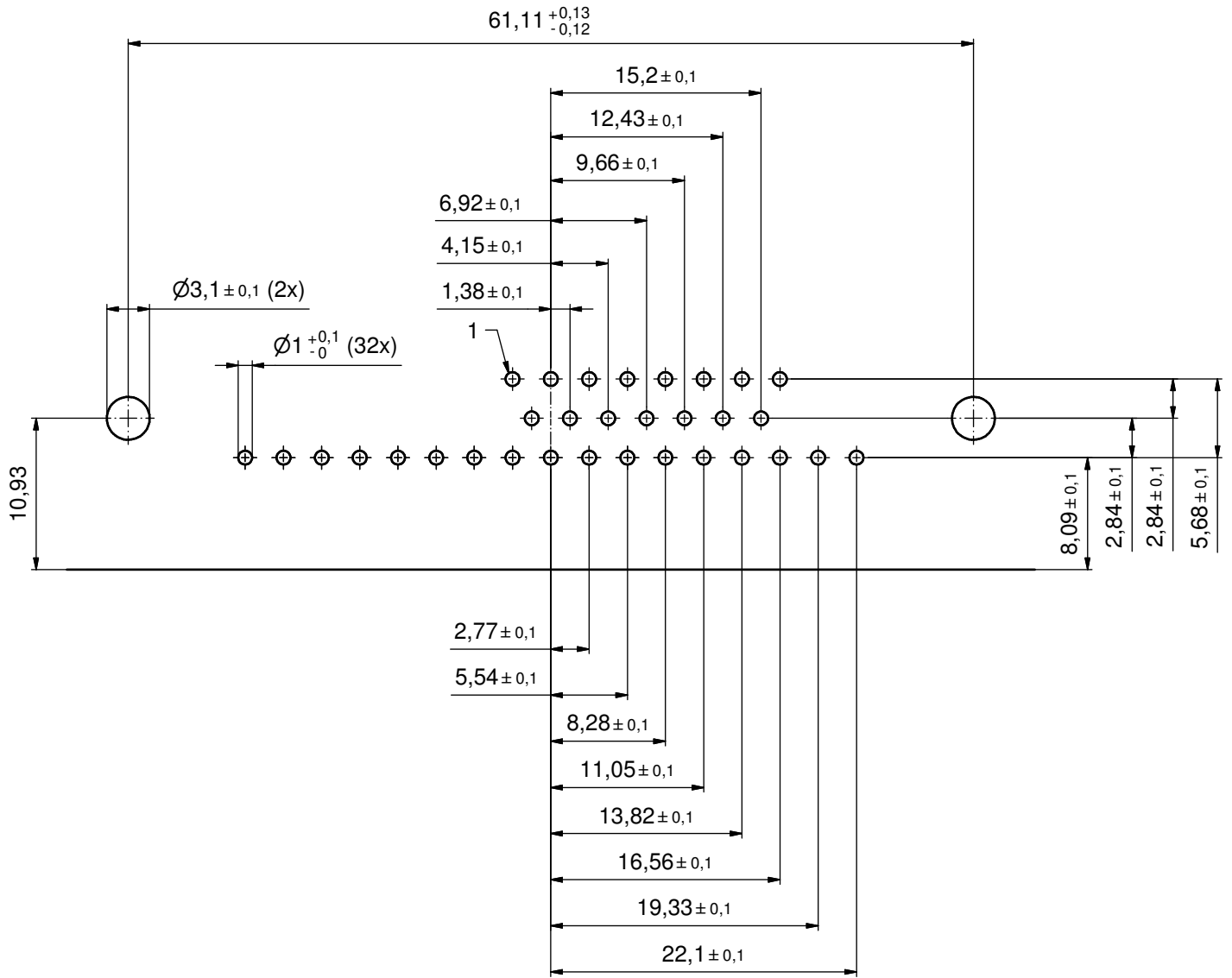

Directive 2002/95/EC RoHS compliant

THIS DRAWING MAY NOT BE COPIED OR REPRODUCED IN ANY WAY, AND MAY NOT BE PASSED ON TO A THIRD PARTY WITHOUT WRITTEN PERMISSION. OWNERSHIP AND COPYRIGHT OF CONEC GmbH DO NOT ALTER CAD DRAWING BY HAND					tolerance		scale: 3:1
					dim. in mm		material: SEE SHEET 1
	rev.	description	date	name	drawn	12.02.13	Henneboel
					appd.	12.02.13	Koch
					norm		
					d-old		
					title:		
					P.C.B. HOLE DRILLINGS		
					D-SUB COMBINATION MALE 90° 36W4P		
					with threaded insert and metal bracket		
				dwg no:			
				13K1A4179			
				part no: SEE SHEET 1			
				DIN-A3			
				sh: 2/2			

