



PART NAME

NEMA DIE CAST ALUM. ENCLOSURE w/MTG. BRKT.

PART No.

AN-2802-A & AN-2802-AB

REVISION DATE

9-30-15

UL LISTED FOR U.S. AND CANADA - FILE #E194432

UPDATE REPLACES PART NO. AN-2802 & AN-2802-B

DRAWING FOR REFERENCE
WE RESERVE THE RIGHT TO MAKE CHANGES TO OUR STANDARD PRODUCTS. PLEASE CONSULT WITH BUD INDUSTRIES PRIOR TO USING THIS DRAWING FOR DESIGN PURPOSE.

TYPE RATING 4, 4X, 6, 6P, 12 AND 13, COMPARE TO IP-68

80°C. MAXIMUM OPERATING TEMPERATURE

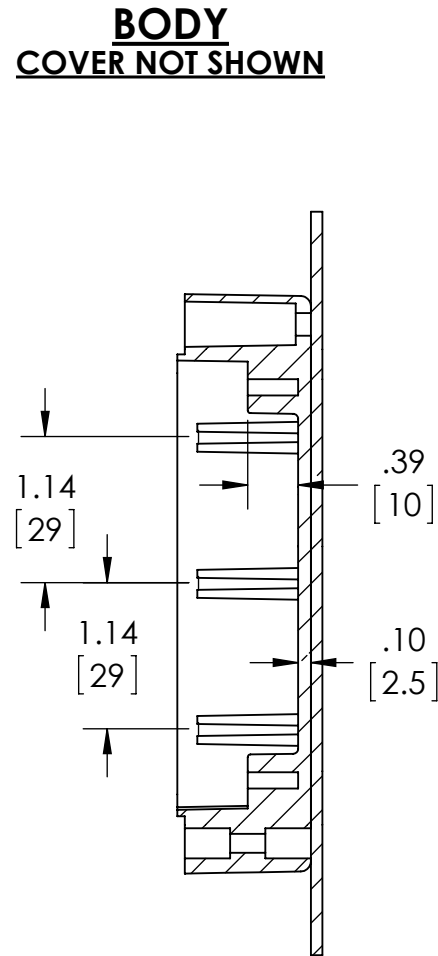
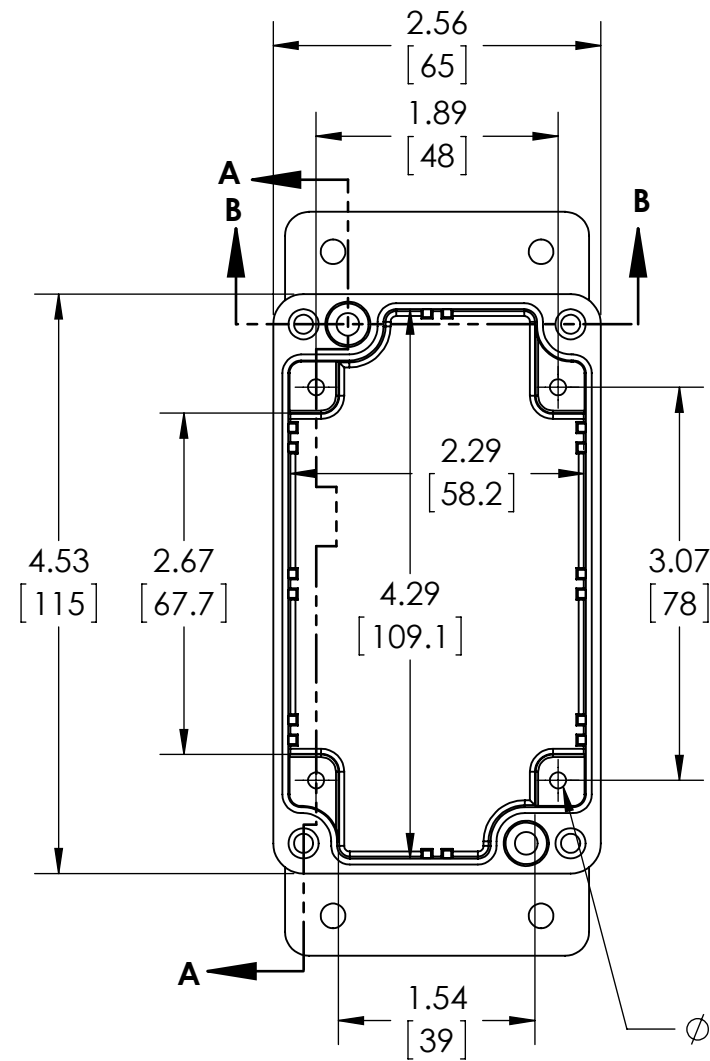

SECTION A-A

ϕ .125 x .350 DEEP (4X)
[3.2] [8.9]
ACCEPTS M3.5 x 6mm LG.
OR #6 x 1/4" LG.
SELF-TAPPING SCREW
(NOT SUPPLIED - FOR PCB
MOUNTING)

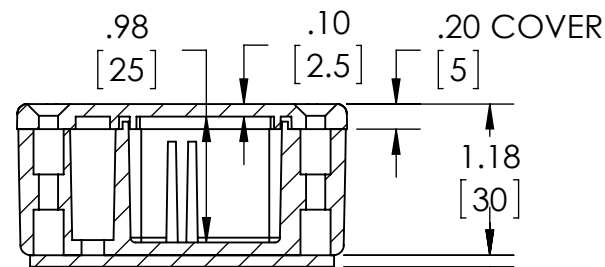

SECTION B-B

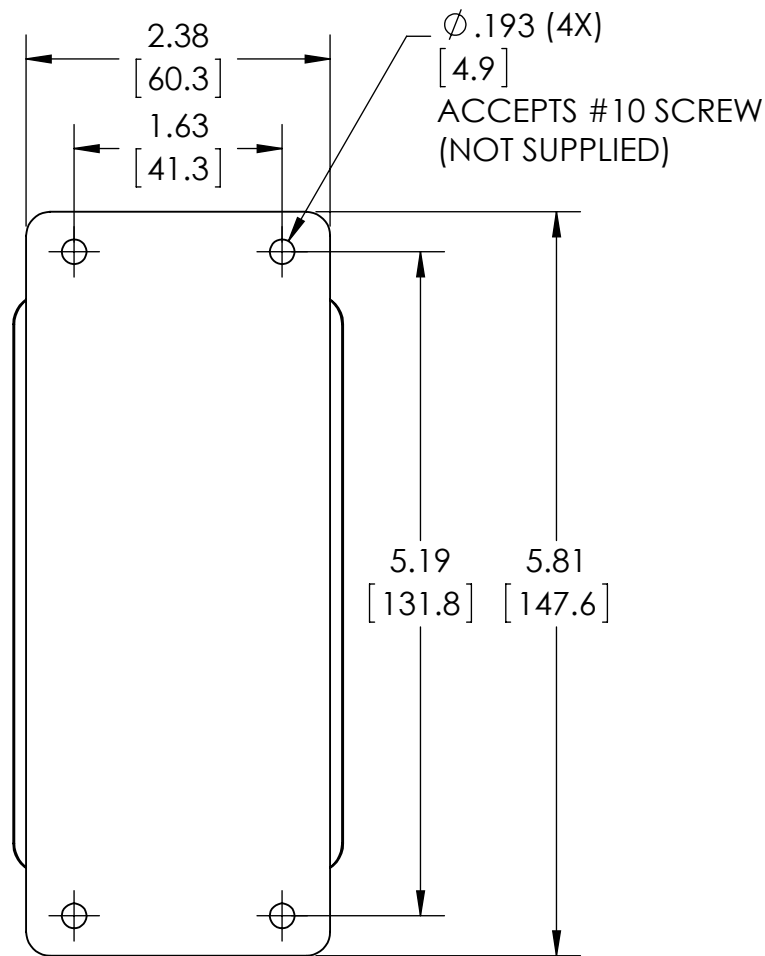

GASKET
(NOT
INSTALLED)
MOLDED SILICONE
GRAY

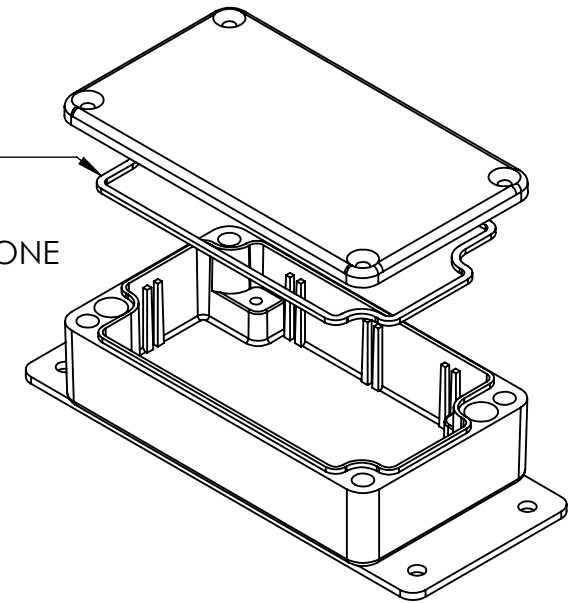

MATERIAL: BODY & COVER - ALUMINUM ALLOY #ADC-12
MOUNTING BRACKET - .09 THK. ALUMINUM (3003-H14)

FINISH: NATURAL (SUFFIX -A)
SMOOTH BLACK POWDERCOAT (SUFFIX -AB)

FOUR (4) M4x0.7 x 20mm (.79") LG. 90° CSK. HEAD
STAINLESS STEEL SCREWS SUPPLIED FOR ASSEMBLY
OF COVER TO BODY. APPLY AT 12 IN./LB. OF
TORQUE.

OUTSIDE AND INSIDE DRAFT ANGLE: 1°
DIMENSIONS ARE INCH[MM]

OPTIONAL ACCESSORIES:
PCB MOUNTING KIT #57-58
INTERNAL PANEL #ANX-91302
REPLACEMENT GASKET #1302GSKTSC

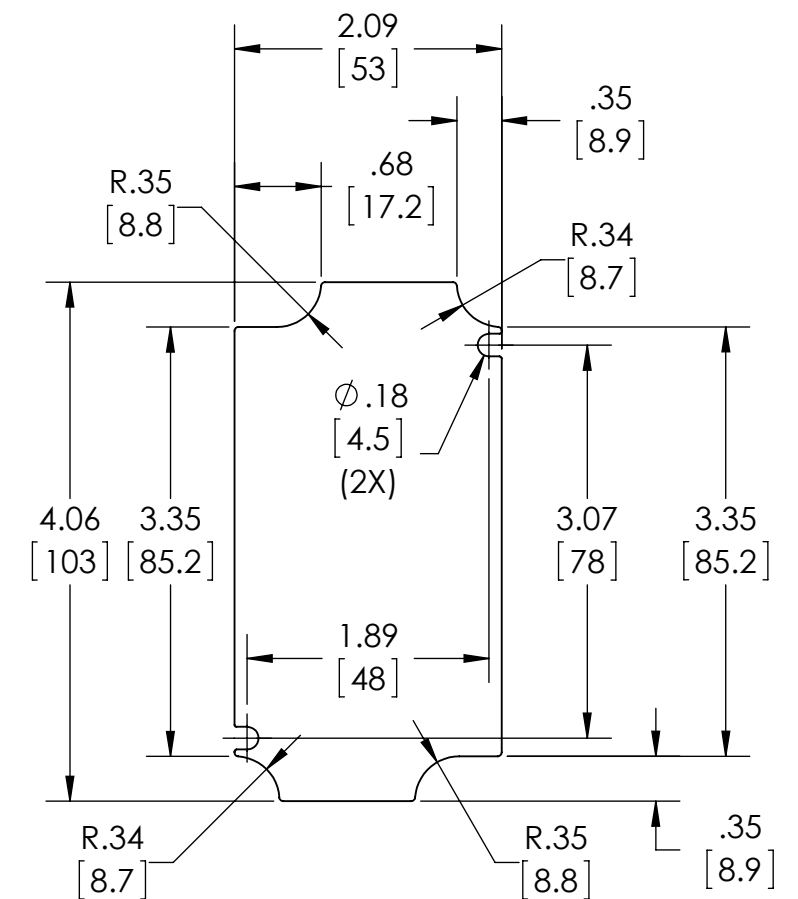

**OPTIONAL INTERNAL PANEL AND
SUGGESTED PC BOARD LAYOUT**