

# LM95172EVM User's Guide

LIST OF FIGURES .....	1
LIST OF TABLES.....	1
1. INTRODUCTION .....	1
2. SETUP .....	2
2.1. INPUT/OUTPUT CONNECTOR DESCRIPTION .....	2
2.2. SETUP.....	4
2.3. SOFTWARE INSTALLATION.....	5
2.4. OPERATION.....	8
3. BOARD LAYOUT.....	12
4. SCHEMATIC.....	13
EVALUATION BOARD/KIT/MODULE (EVM) .....	20

## LIST OF FIGURES

1	VDD IO Jumper Settings .....	2
2	VDDA Analog Source Jumper Settings .....	2
3	LM95172EVM Block Diagram.....	4
4	LM95172EVM .....	8
5	LM95172EVM Layout Diagram.....	12
6	LM95172EVM Schematic .....	13

## LIST OF TABLES

1	Device and Package Configurations.....	1
2	LM95172EVM Bill of Materials.....	13

## 1. Introduction

The LM95172EVM is used together with TI SensorEval software. The Texas Instruments LM95172EWG evaluation module (EVM) helps designers learn about the operation, and evaluate the performance of the LM95172EWG Temperature Sensor chip. The LM95172EVM is powered directly from the +5V line of the USB connection. The microcontroller on the board provides the SPI (Serial Peripheral Interface) bus, and relays the information from the LM95172EVM to the PC via the USB bus.

The EVM contains one Temperature Sensor (See Table 1).

**Table 1: Device and Package Configurations**

TEMP SENSOR	IC	PACKAGE
U3	LM95172EWG	10-pin Cerpack

## 2. Setup

This section describes the jumpers and connectors on the EVM as well as how to properly connect, set up the software and hardware, and use the LM95172EVM. There is no external power supply or signal sources are required for operation of the LM95172EVM; however, there is an option allowing the use of external power supply.

### 2.1. Input/Output Connector Description

**J5 – Input** is the power input terminal for the Temperature Sensor. The terminal header provides a power (VDD IO). This header (IDD IO) can be used to insert the ammeter to measure current into VDD IO pin.

**J6 – input** is the VDD IO source for the LM95172EWG. The terminal header is two way jumpers. It can be jumpered either pin 1-2 or 2-3 to use external power or a regulated internal supply +3.3V.

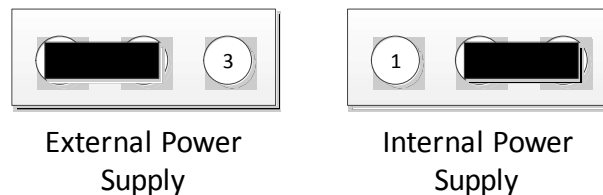

Figure 1: VDD IO Jumper Settings

**J7 – Input** is the input terminal for the external power supply. Pin 1 of J7 is the external VDDA source. Pin 2 of J7 is the GND. Pin 3 of J7 is the external VDD IO source.

**J8 – Input** is the jumper used to enable VDD analog source. The terminal header is two way jumpers. It can be jumpered either pin 1-2 or 2-3 (Figure 1) to use external power or a regulated internal supply +3.3V.

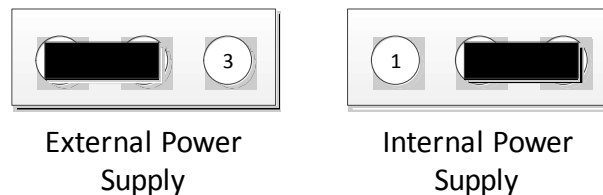

Figure 2: VDDA Analog Source Jumper Settings

**J9 – Input** is the power input terminal for the VDDA analog source. The terminal header provides a power (VDDA analog). This header (IDDA) can be used to insert the ammeter to measure current into VDDA pin.

---

**J10 – Output** is the testpoint terminal. It provides user with signals for test purposes only. Please do not apply any external power or signal to any of the pins on this header.

Setup

**2.2. Setup**

The LM95172EVM along with the SensorEval software provides the designer with a convenient way to learn about the operation of the EVM. The user simply installs the SensorEval software on the PC, connects the USB cable from the PC to the EVM, connects the hardware setting, and it is ready to read the temperature. In figure 3 is the block diagram that describes the EVM itself.

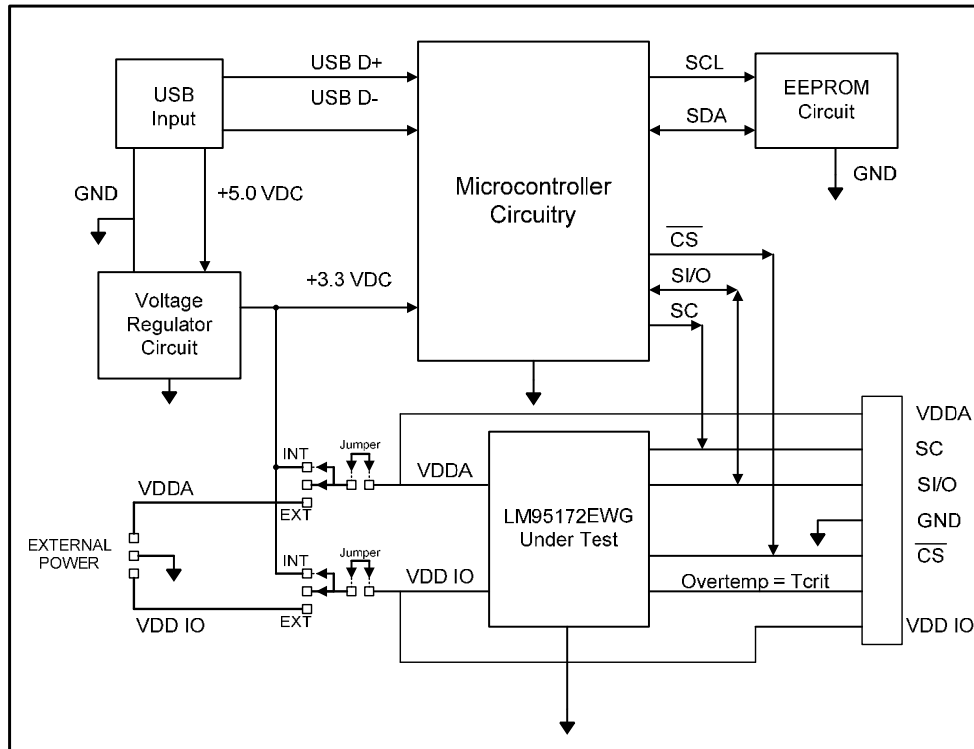

**Figure 3: LM95172EVM Block Diagram**

### 2.3. Software Installation

To ensure that you are using the latest version of SensorEval software, you can download from our website at <http://www.ti.com/tool/sensoreval>. You must install the SensorEval software, before you connect the LM95172EVM to your PC.

To install the SensorEval Software:

- Click this link <http://www.ti.com/tool/sensoreval> then click on the red “download” button and click the “Save” button to save the file to the known directory.

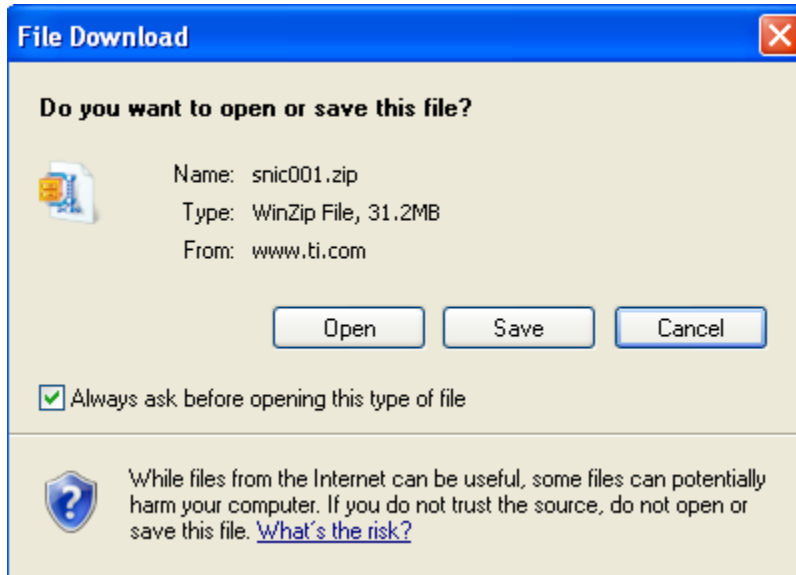

- To open the ZIP file you just download click on the “Open” button.

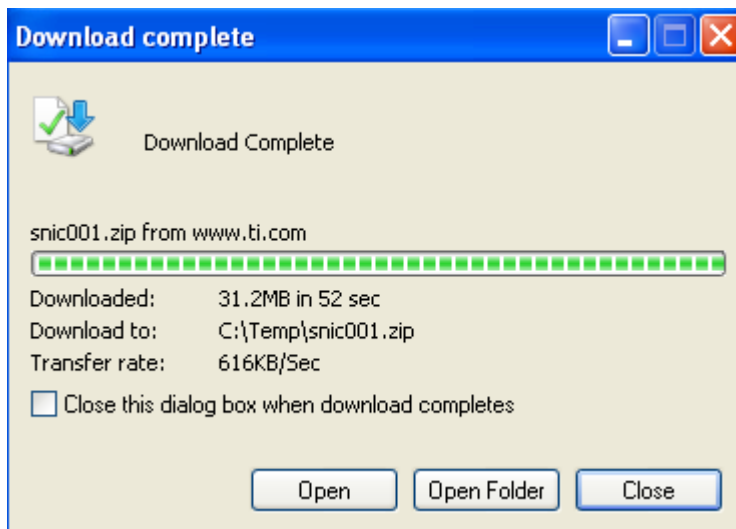

## Setup

- Uncompress the file that you downloaded into a known directory, and run the SensorEval\_1.2.0\_Setup.exe file.

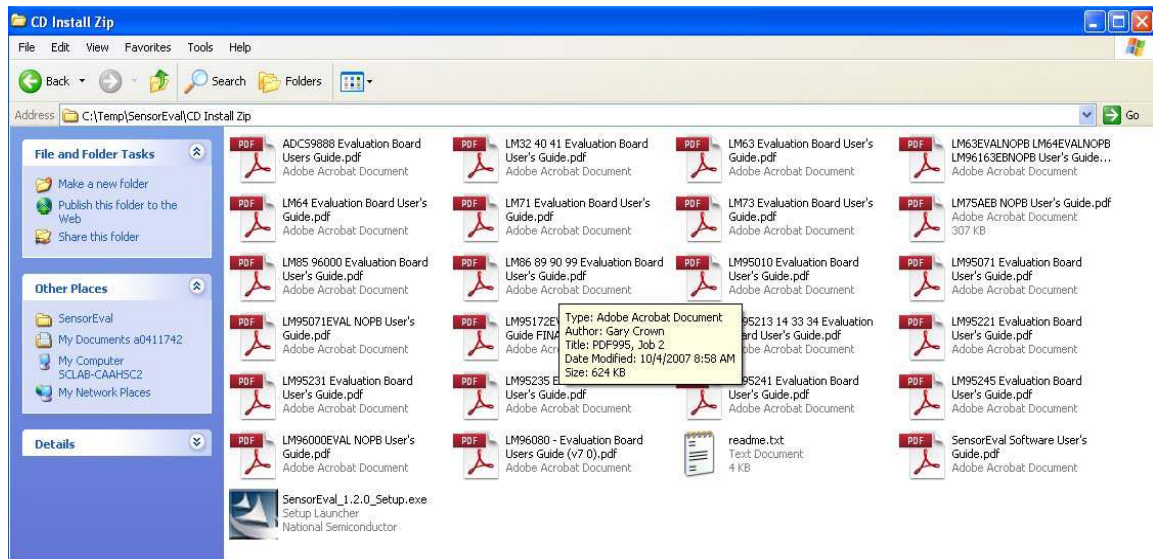

- When you see the Welcome screen as shown below, follow the instructions by clicking the “Next” button on the screen to install the software.
- When you finish the installation, please click “Finish” button.



- Before you launch the SensorEval software, connect LM95172EVM device to one free USB port of your PC. The “New Hardware” screen appears and click the “Next” button.
- A warning sign appears. Click “Continue Anyway” button.



*Setup*

## 2.4. Operation

For proper operation of the LM95172EVM, J5, J6, J8 and J9 should be properly configured. The recommended setting, using shorting blocks, is shown in Figure 4. If U3 of the LM95172EVM is not populated, Finger board must be connected to J10. Fingerboard has a temperature range up to 200°C. One of the best features of this board is that it allows user to insert the board itself into the high temperature.

For this quick start, connect the following jumpers:

1. J5 to short
2. J9 to short
3. J6 pin 2-3 to short
4. J8 pin 2-3 to short

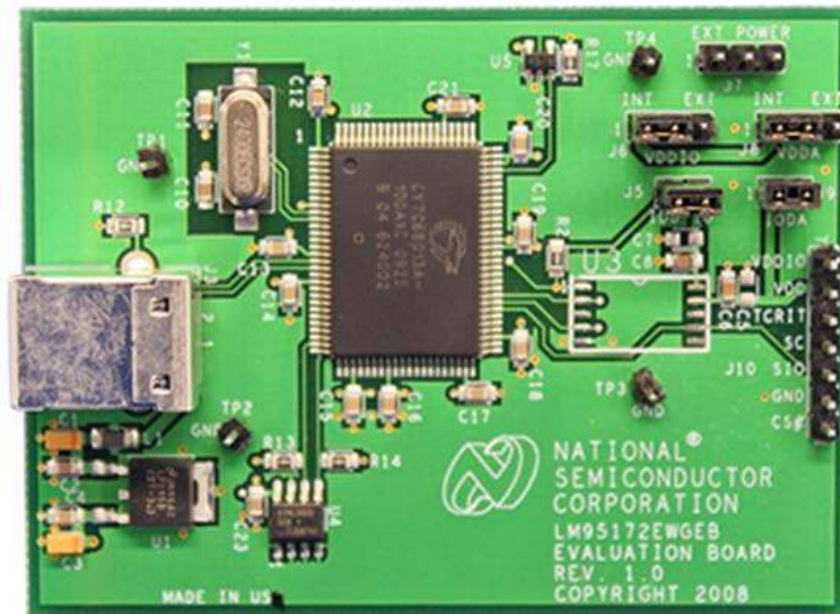

**Figure 4: LM95172EVM**



- Below snapshot is the overview of the setup.

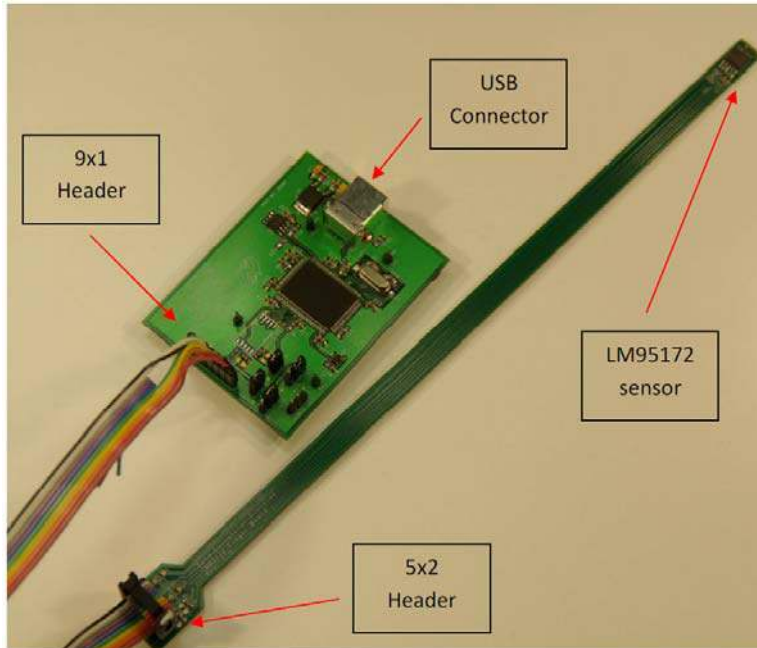

- Align the polarity mark pin 1 of J10 with the ribbon cable alignment mark.

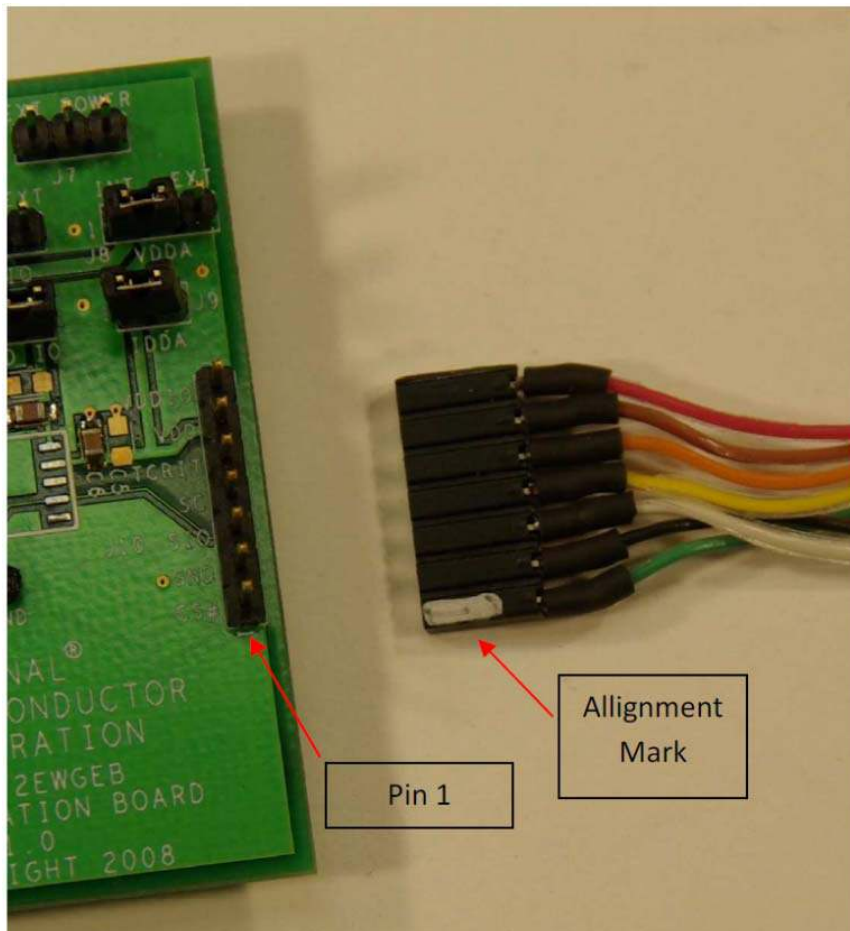

## Setup

- Also align the polarity mark of the ribbon cable alignment with pin 1 of the Fingerboard.

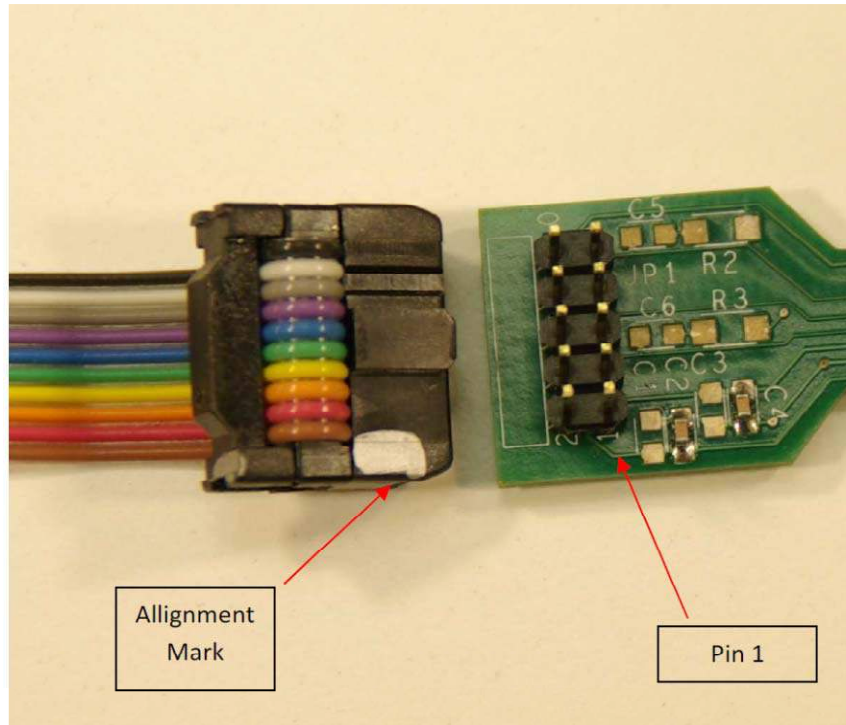

- Once the SensorEval software is installed, and the hardware is setup. You can launch them by clicking the icon on the desktop. The dialog box appears to select the definition file of LM95172.

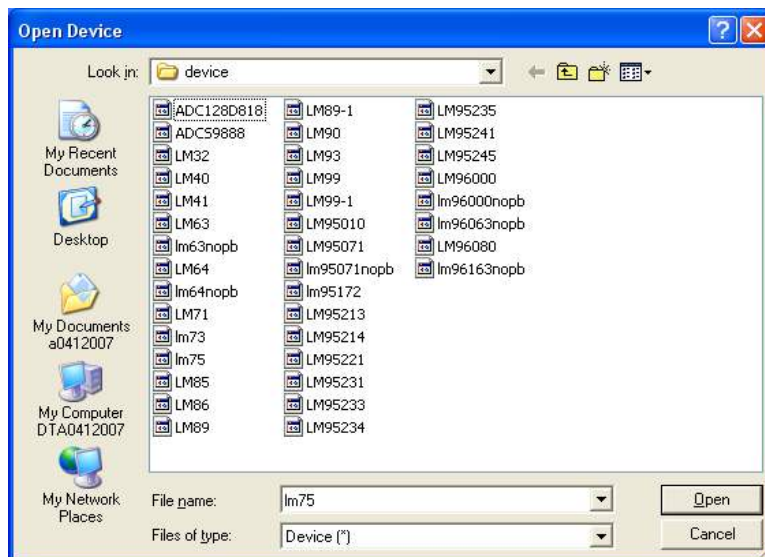

- A confirm screen appears. Click “OK” button.

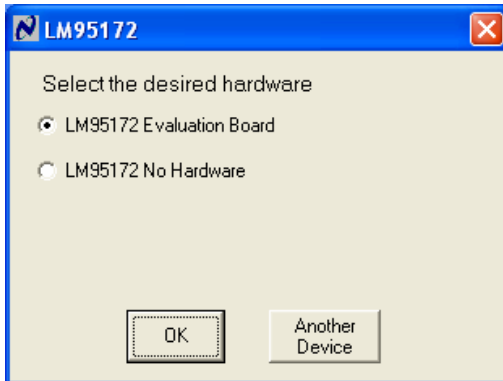

- The SensorEval software will be populated based on the LM95172’s definition file.

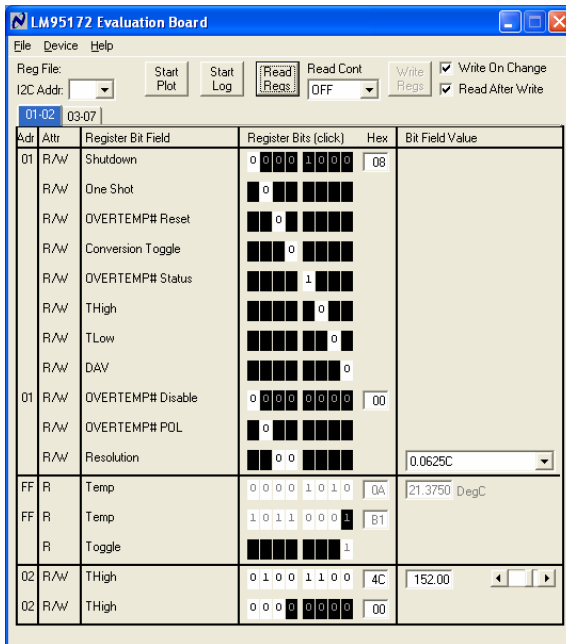

- Select the Read Cont dropdown menu as “All Regs”. This will read the values continuously.
- Changing the value of LM95172’s registers by clicking the white textbox on the Register Bits column

### 3. Board Layout

Figure 5 shows the board layout for the LM95172EVM. The EVM offers quick jumpers setting to read the temperature sensor. It uses the +5V and GND lines from the USB connection. This +5V voltage is regulated down to +3.3V to power the board. If the internal +3.3V is selected for both supply voltages then there is no required for external power. However, the user may select the EXT external power inputs at J7.

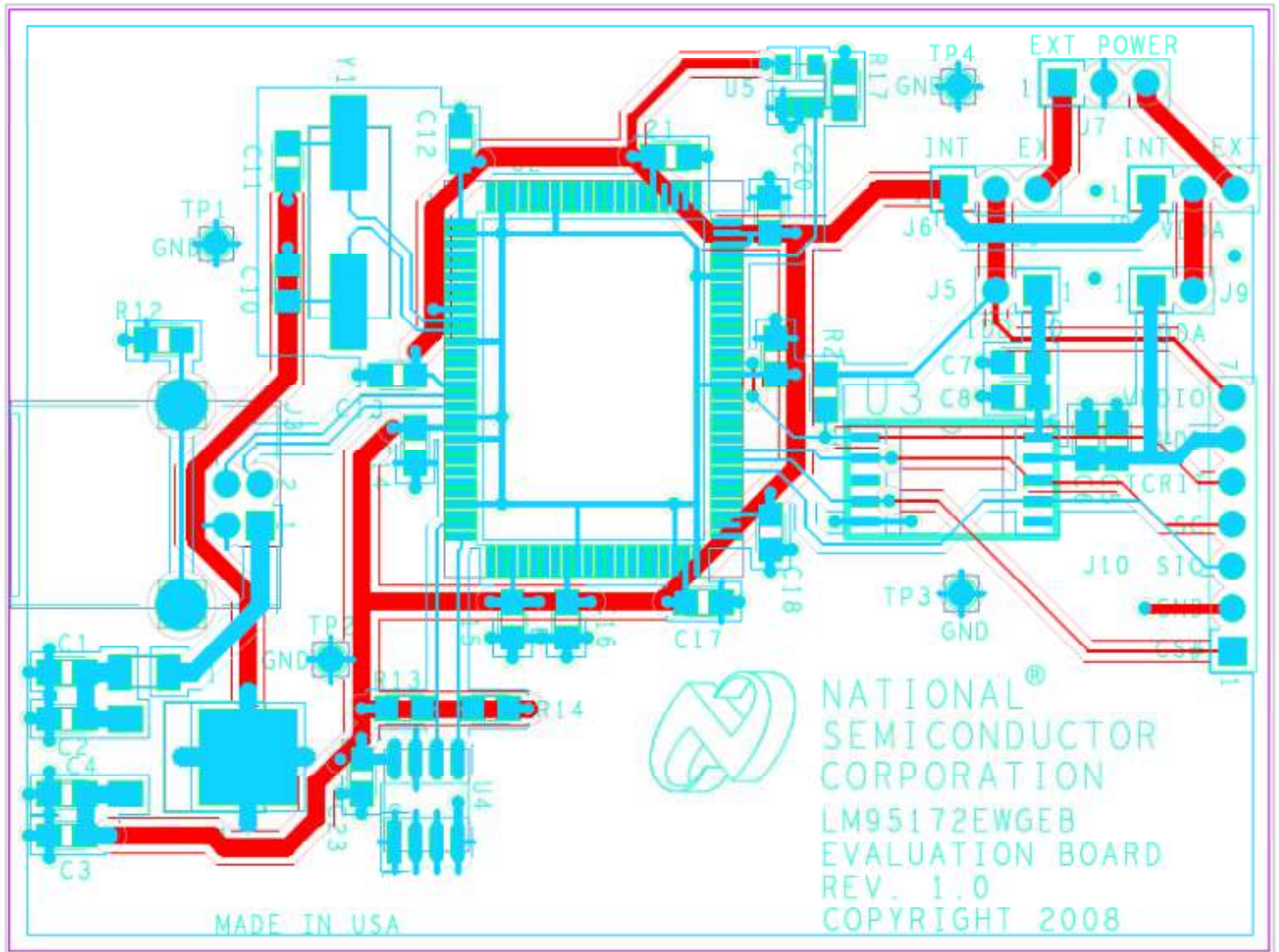

**Figure 5: LM95172EVM Layout Diagram**

4. Schematic

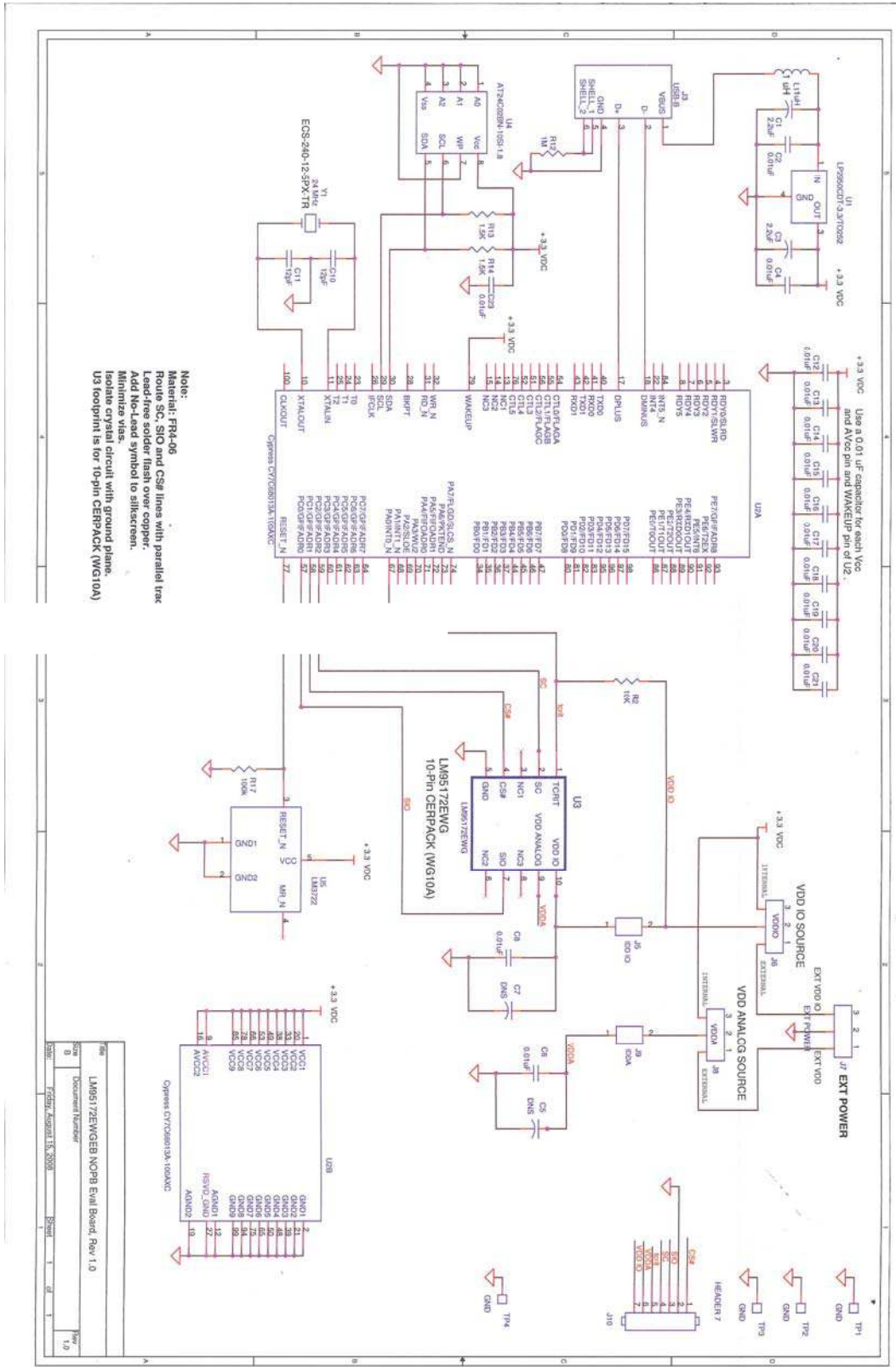

Figure 6: LM95172EVM Schematic



**Table 2: LM95172EVM Bill of Materials**

Item	Qty	Part Reference	Value	Footprint	Description
1	14	C2,C4,C6,C13,C14, C15,C16,C17,C18, C19,C20,C21,C22, C23	10 nF	c0603	
2	2	C1, C3	2.2 uF	c3216	
3	2	C10, C11	12 pF	c0805	
5	1	J3	Connector, USB-B	usb-jack-b	USB Connector Type B, Single Through Hole
6	3	J5, J7, J9	CONN, 1X2Header, 0.1 in centers	TP40	CONN 1 PIN 0.1 TH SINGL ROW HEADER
7	1	J6,J8	CONN, 1X3 Header, 0.1 in centers	TP40	CONN 1 PIN 0.1 TH SINGL ROW HEADER
8	4	TP1,TP2,TP3,TP4	CONN, 1X1 Header, 0.1 in centers	TP40	CONN 1 PIN 0.1 TH SINGL ROW HEADER
9	1	J10	CONN, 1X7 Header, 0.1 in centers	TP41	CONN 1 PIN 0.1 TH SINGL ROW HEADER
8	1	L1	CM CHOKE		CHOKES 90 OHMS PCB
9	1	R2	10k	r0805	RES 10k OHM 1/8W 1% 0805 SMD
9	1	R12	1 Meg	r0805	RES 1.0Meg OHM 1/8W 1% 0805 SMD
10	2	R13,R14	1.5K	r0805	RES 1.5K OHM 1/8W 1% 0805 SMD
11	1	R17	100K	r0805	RES 100K OHM 1/8W 1% 0805 SMD
12	1	U3	Device Under Test (DUT)	10-pin CERPACK	LM95172EWG NOPB High Temp Chip
13	1	U1	LP2950CDT-3.3/TO252	TO263 7P	IC REG Low Dropout
14	1	U2	Cypress CY7C68013A-100AXC	100tqfp	USB MICROCONTROLLER FX2LP 100 PIN
15	1	U4	24C02	soic8	IC SRL EEPROM 2K (256 x 8) 1.8V 8SOIC 2 WIRE
16	1	U5	LM3722	SOT23-stx	5-pin uP reset ckt, sot23-5 pkg, LM3722EM5-3.08
17	1	BOARD	LM95172EWGEB, Rev 1.0		PCB FR4-06 2LYR 62MILS THICK
18	1	Y1	24 MHz	hc49us	CRYSTAL 24.000MHZ

## EVALUATION BOARD/KIT/MODULE (EVM) ADDITIONAL TERMS

Texas Instruments (TI) provides the enclosed Evaluation Board/Kit/Module (EVM) under the following conditions:

The user assumes all responsibility and liability for proper and safe handling of the goods. Further, the user indemnifies TI from all claims arising from the handling or use of the goods.

Should this evaluation board/kit not meet the specifications indicated in the User's Guide, the board/ kit may be returned within 30 days from the date of delivery for a full refund. THE FOREGOING LIMITED WARRANTY IS THE EXCLUSIVE WARRANTY MADE BY SELLER TO BUYER AND IS IN LIEU OF ALL OTHER WARRANTIES, EXPRESSED, IMPLIED, OR STATUTORY, INCLUDING ANY WARRANTY OF MERCHANTABILITY OR FITNESS FOR ANY PARTICULAR PURPOSE. EXCEPT TO THE EXTENT OF THE INDEMNITY SET FORTH ABOVE, NEITHER PARTY SHALL BE LIABLE TO THE OTHER FOR ANY INDIRECT, SPECIAL, INCIDENTAL, OR CONSEQUENTIAL DAMAGES.

Please read the User's Guide and, specifically, the Warnings and Restrictions notice in the User's Guide prior to handling the product. This notice contains important safety information about temperatures and voltages. For additional information on TI's environmental and/or safety programs, please visit [www.ti.com/esh](http://www.ti.com/esh) or contact TI.

No license is granted under any patent right or other intellectual property right of TI covering or relating to any machine, process, or combination in which such TI products or services might be or are used. TI currently deals with a variety of customers for products, and therefore our arrangement with the user is not exclusive. TI assumes no liability for applications assistance, customer product design, software performance, or infringement of patents or services described herein.

Mailing Address: Texas Instruments Post Office Box 655303 Dallas, Texas 75265

Copyright 2012, Texas Instruments Incorporated

## REGULATORY COMPLIANCE INFORMATION

As noted in the EVM User's Guide and/or EVM itself, this EVM and/or accompanying hardware may or may not be subject to the Federal Communications Commission (FCC) and Industry Canada (IC) rules.

For EVMs **not** subject to the above rules, this evaluation board/kit/module is intended for use for ENGINEERING DEVELOPMENT, DEMONSTRATION OR EVALUATION PURPOSES ONLY and is not considered by TI to be a finished end product fit for general consumer use. It generates, uses, and can radiate radio frequency energy and has not been tested for compliance with the limits of computing devices pursuant to part 15 of FCC or ICES-003 rules, which are designed to provide reasonable protection against radio frequency interference. Operation of the equipment may cause interference with radio communications, in which case the user at his own expense will be required to take whatever measures may be required to correct this interference.

### General Statement for EVMs including a radio

User Power/Frequency Use Obligations: This radio is intended for development/professional use only in legally allocated frequency and power limits. Any use of radio frequencies and/or power availability of this EVM and its development application(s) must comply with local laws governing radio spectrum allocation and power limits for this evaluation module. It is the user's sole responsibility to only operate this radio in legally acceptable frequency space and within legally mandated power limitations. Any exceptions to this is strictly prohibited and unauthorized by Texas Instruments unless user has obtained appropriate experimental/development licenses from local regulatory authorities, which is responsibility of user including its acceptable authorization.



## **For EVMs annotated as FCC – FEDERAL COMMUNICATIONS COMMISSION Part 15 Compliant**

### **Caution**

This device complies with part 15 of the FCC Rules. Operation is subject to the following two conditions: (1) This device may not cause harmful interference, and (2) this device must accept any interference received, including interference that may cause undesired operation.

Changes or modifications not expressly approved by the party responsible for compliance could void the user's authority to operate the equipment.

### **FCC Interference Statement for Class A EVM devices**

This equipment has been tested and found to comply with the limits for a Class A digital device, pursuant to part 15 of the FCC Rules. These limits are designed to provide reasonable protection against harmful interference when the equipment is operated in a commercial environment. This equipment generates, uses, and can radiate radio frequency energy and, if not installed and used in accordance with the instruction manual, may cause harmful interference to radio communications. Operation of this equipment in a residential area is likely to cause harmful interference in which case the user will be required to correct the interference at his own expense.

### **FCC Interference Statement for Class B EVM devices**

This equipment has been tested and found to comply with the limits for a Class B digital device, pursuant to part 15 of the FCC Rules. These limits are designed to provide reasonable protection against harmful interference in a residential installation. This equipment generates, uses and can radiate radio frequency energy and, if not installed and used in accordance with the instructions, may cause harmful interference to radio communications. However, there is no guarantee that interference will not occur in a particular installation. If this equipment does cause harmful interference to radio or television reception, which can be determined by turning the equipment off and on, the user is encouraged to try to correct the interference by one or more of the following measures:

- Reorient or relocate the receiving antenna.
- Increase the separation between the equipment and receiver.
- Connect the equipment into an outlet on a circuit different from that to which the receiver is connected.
- Consult the dealer or an experienced radio/TV technician for help.

## **For EVMs annotated as IC – INDUSTRY CANADA Compliant**

This Class A or B digital apparatus complies with Canadian ICES-003.

Changes or modifications not expressly approved by the party responsible for compliance could void the user's authority to operate the equipment.

### **Concerning EVMs including radio transmitters**

This device complies with Industry Canada licence-exempt RSS standard(s). Operation is subject to the following two conditions: (1) this device may not cause interference, and (2) this device must accept any interference, including interference that may cause undesired operation of the device.

### **Concerning EVMs including detachable antennas**

Under Industry Canada regulations, this radio transmitter may only operate using an antenna of a type and maximum (or lesser) gain approved for the transmitter by Industry Canada. To reduce potential radio interference to other users, the antenna type and its gain should be so chosen that the equivalent isotropically radiated power (e.i.r.p.) is not more than that necessary for successful communication.

This radio transmitter has been approved by Industry Canada to operate with the antenna types listed in the user guide with the maximum permissible gain and required antenna impedance for each antenna type indicated. Antenna types not included in this list, having a gain greater than the maximum gain indicated for that type, are strictly prohibited for use with this device.

~

Cet appareil numérique de la classe A ou B est conforme à la norme NMB-003 du Canada.

Les changements ou les modifications pas expressément approuvés par la partie responsable de la conformité ont pu vider l'autorité de l'utilisateur pour actionner l'équipement.

### **Concernant les EVMs avec appareils radio**

Le présent appareil est conforme aux CNR d'Industrie Canada applicables aux appareils radio exempts de licence. L'exploitation est autorisée aux deux conditions suivantes : (1) l'appareil ne doit pas produire de brouillage, et (2) l'utilisateur de l'appareil doit accepter tout brouillage radioélectrique subi, même si le brouillage est susceptible d'en compromettre le fonctionnement.

### **Concernant les EVMs avec antennes détachables**

Conformément à la réglementation d'Industrie Canada, le présent émetteur radio peut fonctionner avec une antenne d'un type et d'un gain maximal (ou inférieur) approuvé pour l'émetteur par Industrie Canada. Dans le but de réduire les risques de brouillage radioélectrique à l'intention des autres utilisateurs, il faut choisir le type d'antenne et son gain de sorte que la puissance isotrope rayonnée équivalente (p.i.r.e.) ne dépasse pas l'intensité nécessaire à l'établissement d'une communication satisfaisante.

Le présent émetteur radio a été approuvé par Industrie Canada pour fonctionner avec les types d'antenne énumérés dans le manuel d'usage et ayant un gain admissible maximal et l'impédance requise pour chaque type d'antenne. Les types d'antenne non inclus dans cette liste, ou dont le gain est supérieur au gain maximal indiqué, sont strictement interdits pour l'exploitation de l'émetteur.

---

## **Important Notice for Users of this Product in Japan]**

### **This development kit is NOT certified as Confirming to Technical Regulations of Radio Law of Japan!**

If you use this product in Japan, you are required by Radio Law of Japan to follow the instructions below with respect to this product:

(1) Use this product in a shielded room or any other test facility as defined in the notification #173 issued by Ministry of Internal Affairs and Communications on March 28, 2006, based on Sub-section 1.1 of Article 6 of the Ministry's Rule for Enforcement of Radio Law of Japan,

(2) Use this product only after you obtained the license of Test Radio Station as provided in Radio Law of Japan with respect to this product, or

(3) Use of this product only after you obtained the Technical Regulations Conformity Certification as provided in Radio Law of Japan with respect to this product.

Also, please do not transfer this product, unless you give the same notice above to the transferee.

Please note that if you could not follow the instructions above, you will be subject to penalties of Radio Law of Japan.

**Texas Instruments Japan Limited**  
**(address) 24-1, Nishi-Shinjuku 6 chome, Shinjuku-ku, Tokyo, Japan**

<http://www.tij.co.jp>

## 【ご使用にあたっての注意】

本開発キットは技術基準適合証明を受けておりません。

本製品のご使用に際しては、電波法遵守のため、以下のいずれかの措置を取っていただく必要がありますのでご注意ください。

- (1) 電波法施行規則第6条第1項第1号に基づく平成18年3月28日総務省告示第173号で定められた電波暗室等の試験設備でご使用いただく。
- (2) 実験局の免許を取得後ご使用いただく。
- (3) 技術基準適合証明を取得後ご使用いただく。

なお、本製品は、上記の「ご使用にあたっての注意」を譲渡先、移転先に通知しない限り、譲渡、移転できないものとなります。

上記を遵守頂けない場合は、電波法の罰則が適用される可能性があることをご留意ください。

日本テキサス・インスツルメンツ株式会社  
東京都新宿区西新宿6丁目24番1号  
西新宿三井ビル  
<http://www.tij.co.jp>

---

# EVALUATION BOARD/KIT/MODULE (EVM)

## WARNINGS, RESTRICTIONS AND DISCLAIMERS

**For Feasibility Evaluation Only, in Laboratory/Development Environments.** Unless otherwise indicated, this EVM is not a finished electrical equipment and not intended for consumer use. It is intended solely for use for preliminary feasibility evaluation in laboratory/development environments by technically qualified electronics experts who are familiar with the dangers and application risks associated with handling electrical mechanical components, systems and subsystems. It should not be used as all or part of a finished end product.

**Your Sole Responsibility and Risk.** You acknowledge, represent and agree that:

1. You have unique knowledge concerning Federal, State and local regulatory requirements (including but not limited to Food and Drug Administration regulations, if applicable) which relate to your products and which relate to your use (and/or that of your employees, affiliates, contractors or designees) of the EVM for evaluation, testing and other purposes.
2. You have full and exclusive responsibility to assure the safety and compliance of your products with all such laws and other applicable regulatory requirements, and also to assure the safety of any activities to be conducted by you and/or your employees, affiliates, contractors or designees, using the EVM. Further, you are responsible to assure that any interfaces (electronic and/or mechanical) between the EVM and any human body are designed with suitable isolation and means to safely limit accessible leakage currents to minimize the risk of electrical shock hazard.
3. You will employ reasonable safeguards to ensure that your use of the EVM will not result in any property damage, injury or death, even if the EVM should fail to perform as described or expected.
4. You will take care of proper disposal and recycling of the EVM's electronic components and packing materials.

**Certain Instructions.** It is important to operate this EVM within TI's recommended specifications and environmental considerations per the user guidelines. Exceeding the specified EVM ratings (including but not limited to input and output voltage, current, power, and environmental ranges) may cause property damage, personal injury or death. If there are questions concerning these ratings please contact a TI field representative prior to connecting interface electronics including input power and intended loads. Any loads applied outside of the specified output range may result in unintended and/or inaccurate operation and/or possible permanent damage to the EVM and/or interface electronics. Please consult the EVM User's Guide prior to connecting any load to the EVM output. If there is uncertainty as to the load specification, please contact a TI field representative. During normal operation, some circuit components may have case temperatures greater than 60°C as long as the input and output are maintained at a normal ambient operating temperature. These components include but are not limited to linear regulators, switching transistors, pass transistors, and current sense resistors which can be identified using the EVM schematic located in the EVM User's Guide. When placing measurement probes near these devices during normal operation, please be aware that these devices may be very warm to the touch. As with all electronic evaluation tools, only qualified personnel knowledgeable in electronic measurement and diagnostics normally found in development environments should use these EVMs.

**Agreement to Defend, Indemnify and Hold Harmless.** You agree to defend, indemnify and hold TI, its licensors and their representatives harmless from and against any and all claims, damages, losses, expenses, costs and liabilities (collectively, "Claims") arising out of or in connection with any use of the EVM that is not in accordance with the terms of the agreement. This obligation shall apply whether Claims arise under law of tort or contract or any other legal theory, and even if the EVM fails to perform as described or expected.

**Safety-Critical or Life-Critical Applications.** If you intend to evaluate the components for possible use in safety critical applications (such as life support) where a failure of the TI product would reasonably be expected to cause severe personal injury or death, such as devices which are classified as FDA Class III or similar classification, then you must specifically notify TI of such intent and enter into a separate Assurance and Indemnity Agreement.

## IMPORTANT NOTICE

Texas Instruments Incorporated and its subsidiaries (TI) reserve the right to make corrections, modifications, enhancements, improvements, and other changes to its products and services at any time and to discontinue any product or service without notice. Customers should obtain the latest relevant information before placing orders and should verify that such information is current and complete. All products are sold subject to TI's terms and conditions of sale supplied at the time of order acknowledgment.

TI warrants performance of its hardware products to the specifications applicable at the time of sale in accordance with TI's standard warranty. Testing and other quality control techniques are used to the extent TI deems necessary to support this warranty. Except where mandated by government requirements, testing of all parameters of each product is not necessarily performed.

TI assumes no liability for applications assistance or customer product design. Customers are responsible for their products and applications using TI components. To minimize the risks associated with customer products and applications, customers should provide adequate design and operating safeguards.

TI does not warrant or represent that any license, either express or implied, is granted under any TI patent right, copyright, mask work right, or other TI intellectual property right relating to any combination, machine, or process in which TI products or services are used. Information published by TI regarding third-party products or services does not constitute a license from TI to use such products or services or a warranty or endorsement thereof. Use of such information may require a license from a third party under the patents or other intellectual property of the third party, or a license from TI under the patents or other intellectual property of TI. Reproduction of information in TI data books or data sheets is permissible only if reproduction is without alteration and is accompanied by all associated warranties, conditions, limitations, and notices.

Reproduction of this information with alteration is an unfair and deceptive business practice. TI is not responsible or liable for such altered documentation. Resale of TI products or services with statements different from or beyond the parameters stated by TI for that product or service voids all express and any implied warranties for the associated TI product or service and is an unfair and deceptive business practice. TI is not responsible or liable for any such statements.

TI products are not authorized for use in safety-critical applications (such as life support) where a failure of the TI product would reasonably be expected to cause severe personal injury or death, unless officers of the parties have executed an agreement specifically governing such use. Buyers represent that they have all necessary expertise in the safety and regulatory ramifications of their applications, and acknowledge and agree that they are solely responsible for all legal, regulatory and safety-related requirements concerning their products and any use of TI products in such safety-critical applications, notwithstanding any applications-related information or support that may be provided by TI. Further, Buyers must fully indemnify TI and its representatives against any damages arising out of the use of TI products in such safety-critical applications.

TI products are neither designed nor intended for use in military/aerospace applications or environments unless the TI products are specifically designated by TI as military-grade or "enhanced plastic." Only products designated by TI as military-grade meet military specifications. Buyers acknowledge and agree that any such use of TI products which TI has not designated as military-grade is solely at the Buyer's risk, and that they are solely responsible for compliance with all legal and regulatory requirements in connection with such use.

TI products are neither designed nor intended for use in automotive applications or environments unless the specific TI products are designated by TI as compliant with ISO/TS 16949 requirements. Buyers acknowledge and agree that, if they use any non-designated products in automotive applications, TI will not be responsible for any failure to meet such requirements.

Following are URLs where you can obtain information on other Texas Instruments products and application solutions:

### Products

Amplifiers	<a href="http://amplifier.ti.com">amplifier.ti.com</a>
Data Converters	<a href="http://dataconverter.ti.com">dataconverter.ti.com</a>
DSP	<a href="http://dsp.ti.com">dsp.ti.com</a>
Interface	<a href="http://interface.ti.com">interface.ti.com</a>
Logic	<a href="http://logic.ti.com">logic.ti.com</a>
Power Mgmt	<a href="http://power.ti.com">power.ti.com</a>
Microcontrollers	<a href="http://microcontroller.ti.com">microcontroller.ti.com</a>
RFID	<a href="http://www.ti-rfid.com">www.ti-rfid.com</a>
Low Power	<a href="http://www.ti.com/lpw">www.ti.com/lpw</a>
Wireless	

### Applications

Audio	<a href="http://www.ti.com/audio">www.ti.com/audio</a>
Automotive	<a href="http://www.ti.com/automotive">www.ti.com/automotive</a>
Broadband	<a href="http://www.ti.com/broadband">www.ti.com/broadband</a>
Digital Control	<a href="http://www.ti.com/digitalcontrol">www.ti.com/digitalcontrol</a>
Military	<a href="http://www.ti.com/military">www.ti.com/military</a>
Optical Networking	<a href="http://www.ti.com/opticalnetwork">www.ti.com/opticalnetwork</a>
Security	<a href="http://www.ti.com/security">www.ti.com/security</a>
Telephony	<a href="http://www.ti.com/telephony">www.ti.com/telephony</a>
Video & Imaging	<a href="http://www.ti.com/video">www.ti.com/video</a>
Wireless	<a href="http://www.ti.com/wireless">www.ti.com/wireless</a>

Mailing Address: Texas Instruments, Post Office Box 655303, Dallas, Texas 75265

Copyright © 2007, Texas Instruments Incorporated