

LT8603

42V, Low I_Q, Quad Output Triple Monolithic Buck Converter and Boost Controller

DESCRIPTION

Demonstration Circuit 2114A features the **LT[®]8603** with triple monolithic buck regulators and a boost controller. The demo circuit is designed for 8.0V, 5.0V, 3.3V, and 1.8V outputs from a nominal 12V input. The 4th channel is set as a boost converter and is powered from a wide input range with output VOUT4 regulated at 8V if $3V < V_{IN} < 8.5V$. It works as diode pass through if the input is above 8.5V. The two high voltage buck regulators are powered from the boost converter. VOUT1 is regulated at 5V with 1.5A maximum output load current, and VOUT2 is at 3.3V with 2.5A maximum output load current. Thanks to the pre-boost converter, they can ride through a cold crank in automotive applications while providing constant output voltages 5V and 3.3V. The low voltage buck is powered from the VOUT2 (3.3V), and the output VOUT3 is regulated at 1.8V with 1.8A maximum load current.

All regulators are synchronized to an internal oscillator that can be programmed with one resistor at the RT pin. Programmable frequency allows optimization between efficiency and external component size. To avoid the audio band, the demo circuit 2114A sets the switching frequency at 2MHz for the three buck regulators, and the boost converter is at 400kHz. At all frequencies, a 180° phase shift is maintained between 1 and 2 channels, reducing the input peak current and voltage ripple.

Many popular features such as soft-start, cycle-by-cycle current limit, and power good for each of the four channels are packed in the 40-Lead 6mm × 6mm QFN package to simplify the complex design of quad-output power converters. Each buck regulator can be independently disabled using its own TRKSS or RUN pin. The boost channel can be disabled by pulling down both the FSEL4A and FSEL4B. The EN/UVLO can be used to shut down the circuit to reduce the input current to 1μA.

Table 1 summarizes the performance of the demo board at room temperature. The demo circuit can be easily modified for various automotive, transportation and industry applications.

The demo board has an EMI filter installed on the bottom layer. The conducted and radiated EMI performance of the board is shown on Figure 4 with 1A load at each of the buck outputs at nominal input 14V. It shows the circuit passes the CISPR 25 Class 5, Peak Limit.

The LT8603 data sheet gives a complete description of the part, operation and application information. The data sheet must be read in conjunction with this quick start guide for Demo Circuit 2114A.

Design files for this circuit board are available at <http://www.linear.com/demo/DC2114A>

All registered trademarks and trademarks are the property of their respective owners.

PERFORMANCE SUMMARY Specifications are at T_A = 25°C

PARAMETER	CONDITIONS	MIN	TYP	MAX	UNITS
Operation Input Voltage Range*		3	14	42	V
Minimum Start-Up, V _{IN(MIN)}				4.5	V
Standby Current when Switching	IOUT1,2,3,4 = 0mA, V _{IN} = 12V		40		μA
Channel 4 Output Voltage, VOUT4	2V < V _{IN} < 8.5V, IOUT4 = 1A	7.68	8	8.32	V
	8.5V < V _{IN}		V _{IN} - 0.5		V
Channel 1 Output Voltage, VOUT1	IOUT1 = 1.5A	4.86	5	5.14	V
Channel 2 Output Voltage, VOUT2	IOUT2 = 2.5A	3.17	3.3	3.43	V
Channel 3 Output Voltage, VOUT3	IOUT3 = 1.8A	1.73	1.8	1.87	V

dc2114af

DEMO MANUAL DC2114A

PERFORMANCE SUMMARY Specifications are at T_A = 25°C

PARAMETER	CONDITIONS	MIN	TYP	MAX	UNITS
Maximum Output Current, IOU1	VIN = 12V	1.5			A
Maximum Output Current, IOU2	VIN = 12V, IOU3 = 0A	2.5			A
Maximum Output Current, IOU3	VIN = 12V, IOU2,4 = 0A	1.8			A
Maximum Output Current, IOU4	VIN = 4V, IOU1,2,3 = 0A	1.5			A
Switching Frequency, Channel 1~3	VIN = 12V, IOU1,2,3 = 1.0A	1.85	2	2.15	MHz
Switching Frequency, Channel 4	VIN = 4V, IOU4 = 1.0A	370	400	430	kHz
Efficiency, Channel 4	VIN = 3.3V, IOU4 = 1.5A		85		%
Efficiency, CH1, 5V	VIN = 12V, IOU1 = 1.5A		90		%
Efficiency, CH2, 3.3V	VIN = 12V, IOU2 = 2.5A		84		%
Efficiency, CH3, 1.8V	PVIN3 = 3.3V, IOU3 = 1.8A		83		%
Efficiency, Overall	VIN = 12V, IOU1,2,3 = 1.0A		80		%

*Refer to data sheet derating curve to determine the maximum input voltage and load.

QUICK START PROCEDURE

Demo Circuit 2114A is easy to set up to evaluate the performance of the LT8603. Refer to Figure 1 for proper equipment setup and follow these procedures.

1. With power off, connect the input power supply to the board through VIN and GND terminals on the top layer. Connect the loads to the terminals VOUT1 and GND, VOUT2 and GND, VOUT3 and GND on the board. The default positions of the Headers are given in Table 2.

Table 2. Default Positions of the Headers

NAME		POSITION
EN/UVLO	JP4	ON
TRKSS1	JP1	ON
TRKSS2	JP2	ON
RUN3	JP3	RUN

2. Set the DC power supply at 6V. Turn on the power at the input.

NOTE: Make sure that the input voltage is always within spec. Refer to data sheet on the switching waveforms in high VIN condition and the Burst Mode[®] operation in light load. The minimum startup voltage for the boost converter (and the board) is 4.5V. Once it starts, the circuit maintains the output regulation with input going down below 3V at light load.

3. Check for the proper switching frequency and output voltage at Channel 4 when it runs as a boost converter. The boost output is set at 8V (±4%).

NOTE: If the boost output is not regulated, temporarily disconnect the load, and disable the two high voltage buck regulators (Channels 1, 2) as well. Check if the EN/UVLO is set in correct position. Check if too much load is applied to VOUT4.

NOTE: The boost converter output current capability depends on the input voltage applied to the demo circuit.

NOTE: The output voltage at the boost converter is V_{IN} – 0.5V when the input is higher than 8.5V. The maximum V_{IN} is 42V.

NOTE: By default, the switching frequency of the boost converter is optimized with 400kHz with FSEL4A Low and FSEL4B High. The switching frequency can be changed with RT, or different FSEL4A / FSEL4B settings. An accompanying change of inductor might be necessary to achieve desirable performance of the converter.

4. Check for the proper output voltages of the buck regulators. The output should be regulated at 5.0V (±4%), 3.3V (±4%), 1.8V (±4%) for the Channels 1, 2 and 3, respectively.

QUICK START PROCEDURE

NOTE: Do not overload the buck regulators simultaneously at high line unless a proper thermal cooling method such as air flow or heat sink is applied.

NOTE: If there is no output, temporarily disconnect the load of the corresponding channels to make sure that the loads are not set too high, and the Headers of EN/UVLO, TRKSS1, TRKSS2, RUN3 are set in the right positions.

5. Once the proper output voltage is established, adjust the input voltage and load currents within the operating range, and observe the output voltage regulation, transient, ripple voltage, efficiency and other parameters.

NOTE: Refer to the thermal derating curves in LT8603 data sheet for high input voltage and/or high ambient temperature operations.

NOTE: By default, the circuit is set in low ripple Burst Mode operation with SYNC grounded. Remove R11, and add 0Ω at R10, the circuit is set in pulse skip mode. The circuit runs in full frequency with lower load current in this mode. To synchronize to an external clock, apply the external clock to the SYNC turret.

NOTE: When measuring the input or output voltage ripples, care must be taken to avoid a long ground lead on the oscilloscope probe. Measure the input or output voltage ripple by touching the probe tip directly across the VIN or VOUT capacitor terminals. See Figure 2 for proper scope probe technique. Figure 6 show the output ripples at the output terminals with additional $10\mu\text{F}$ cap at C13, C19 and C23.

6. The EMI filter is assembled on the bottom layer of the demo circuit. Connect the EMI test facility to the terminals of VEMI+ and VEMI– with very short wires. Connect proper resistor loads to the output terminals of the demo circuit with very short wires. Figure 4 shows the demo circuit 2114A passes the conducted and radiated EMI standard CISPR 25 Class 5 Peak Limit.
7. The switching frequency ($f_{\text{SW}4}$) of the boost channel is set at 1/5 of the channel 2. To modify the boost converter for different switching frequency, change the R24, R25, R26, R27 accordingly.

QUICK START PROCEDURE

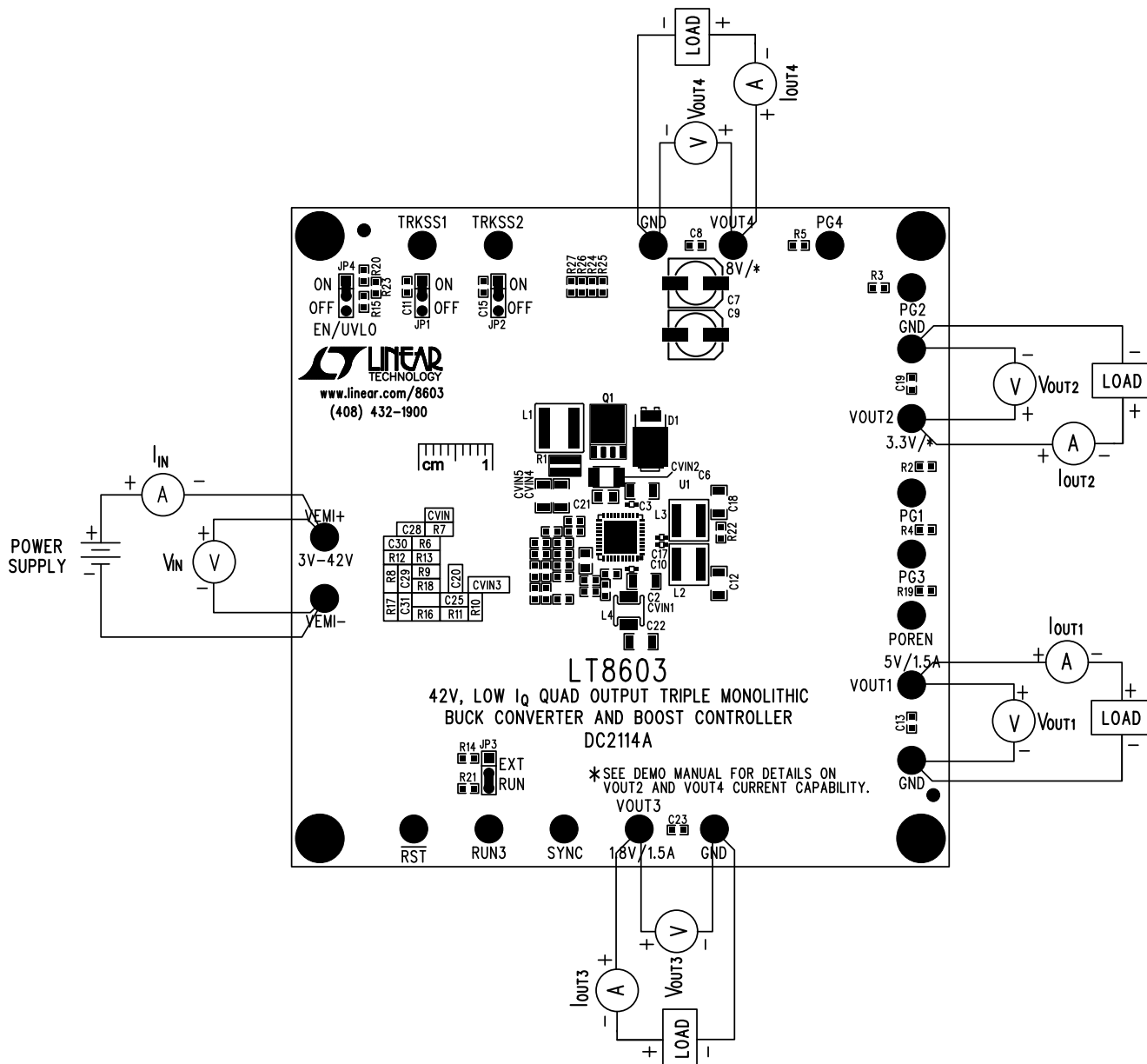

Figure 1. Proper Measurement Equipment Setup for DC2114A

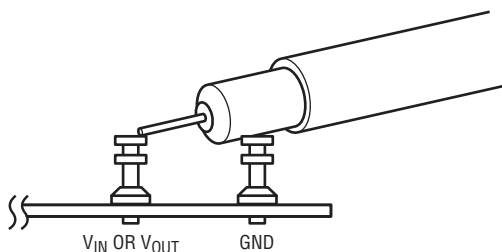
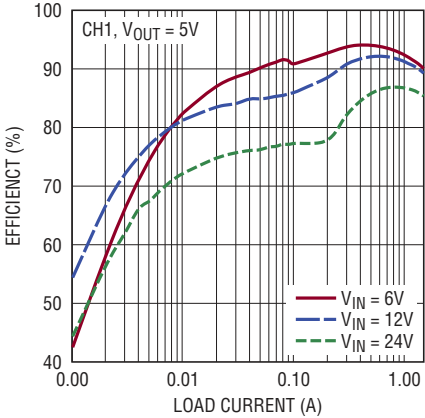
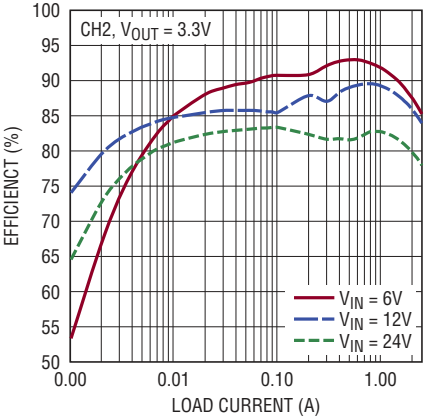

Figure 2. Proper Scope Probe Placement for Measuring Input or Output Ripple

QUICK START PROCEDURE



dc2114a F03a



dc2114a F03b

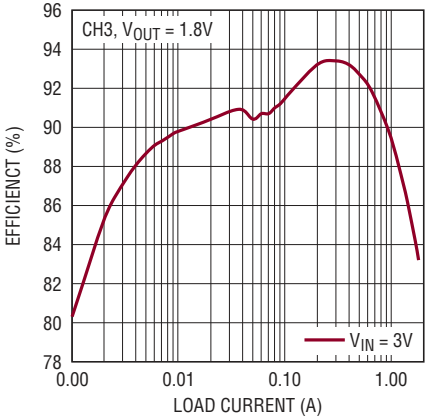

dc2114a F03c

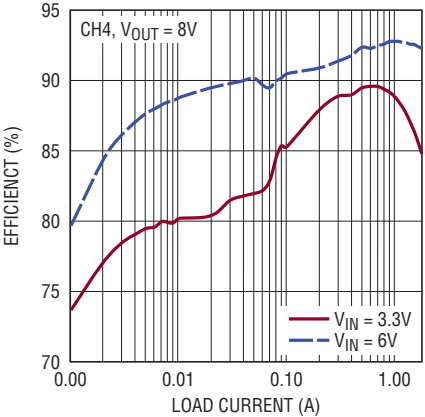

dc2114a F03d

Figure 3. Typical Efficiency Curves, Burst Mode Operation

QUICK START PROCEDURE

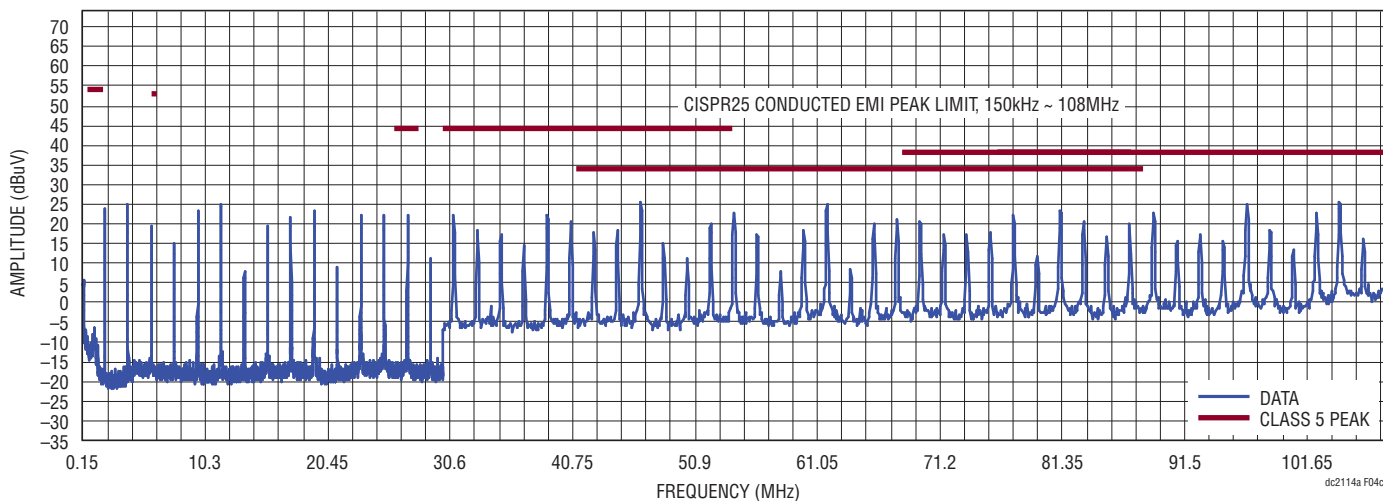
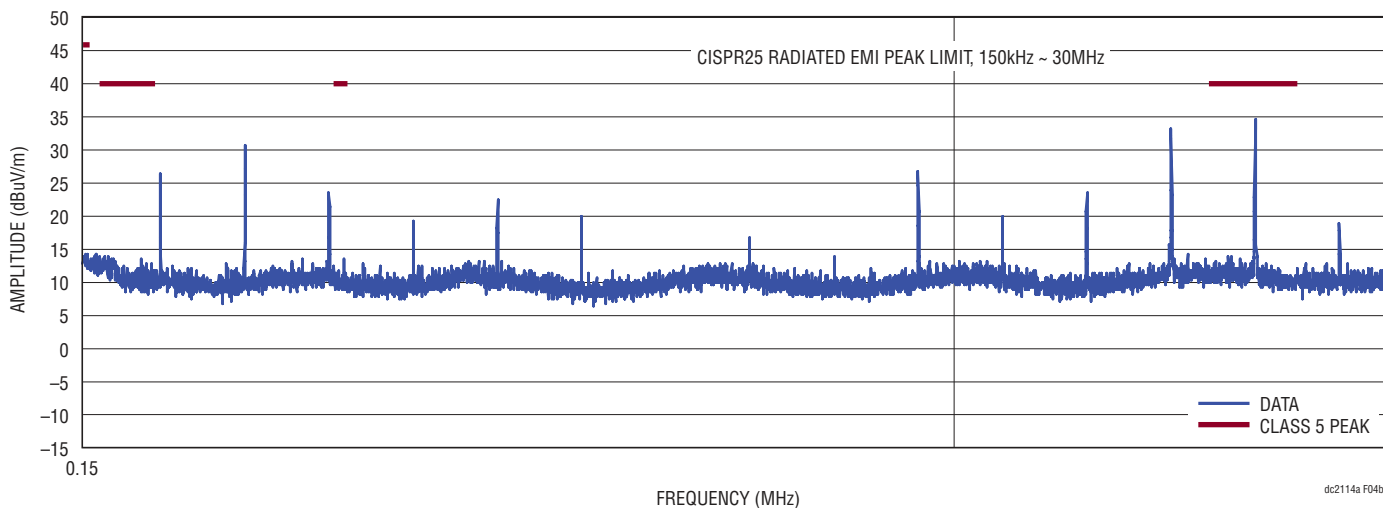
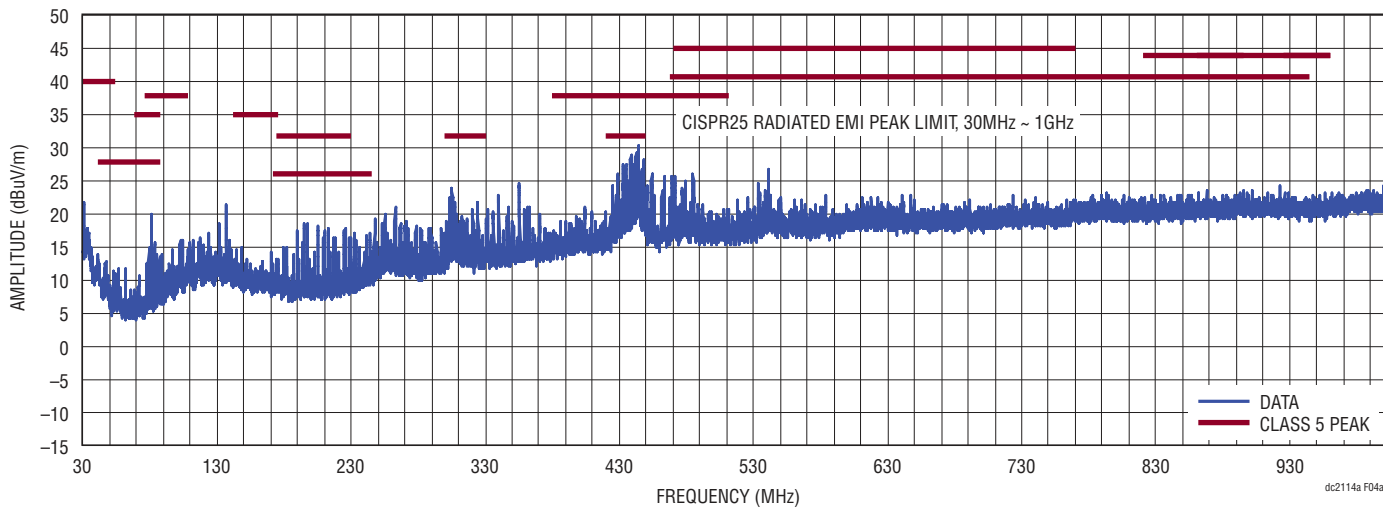
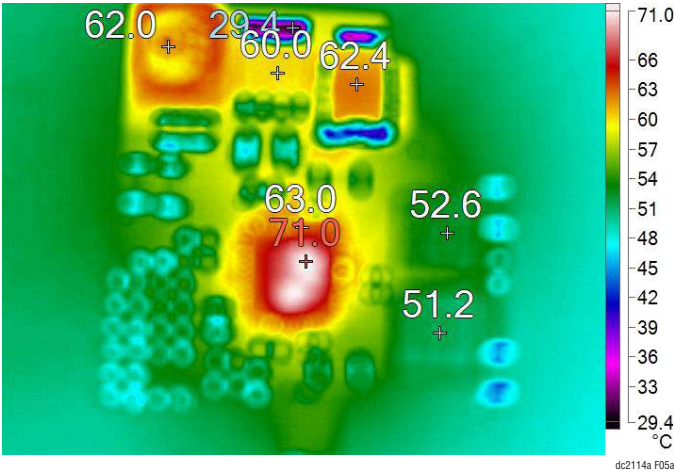
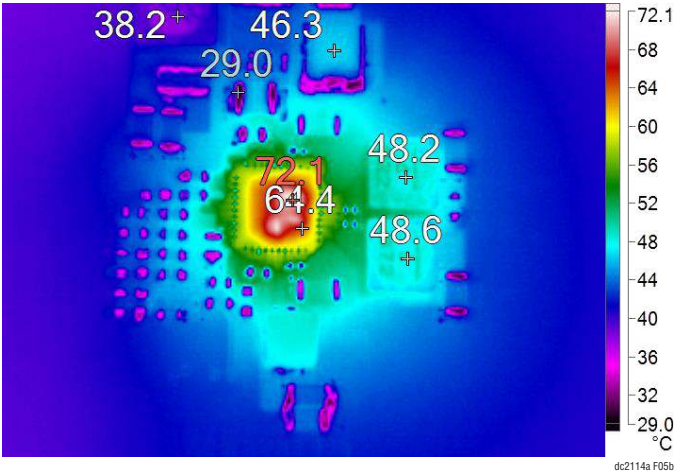

Figure 4. DC2114A Conducted and Radiated Peak EMI - Passes CISPR25-Class 5 Limits. Condition: $V_{IN} = 14V$, $I_{OUT1,2,3} = 1A$, $f_{SW} = 2MHz$

QUICK START PROCEDURE



A. VIN = 3.3V



B. VIN = 24V

Figure 5. Thermal Image Top View, IOUT1 = 1A, IOUT2 = 1A, IOUT3 = 1.5A, TA = 25°C, fSW = 2MHz

QUICK START PROCEDURE

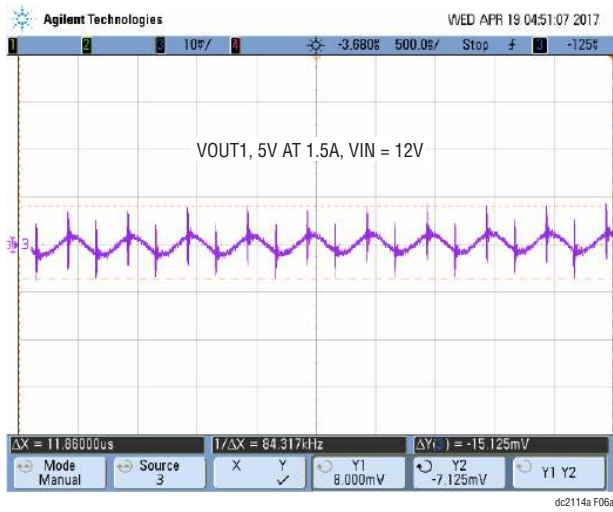

A. VOUT1 RIPPLE

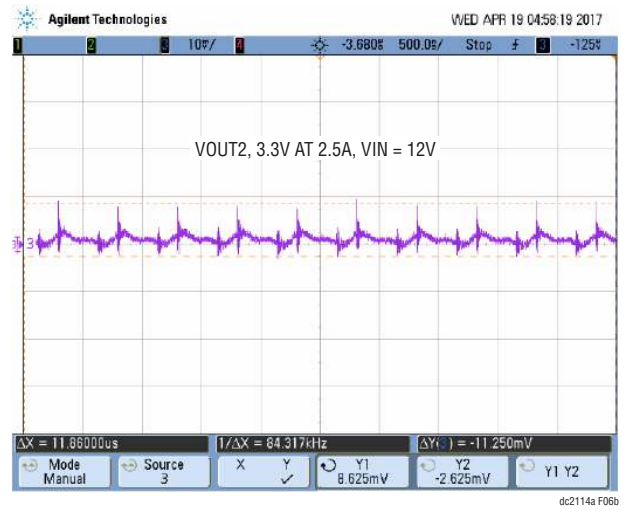

B. VOUT2 RIPPLE

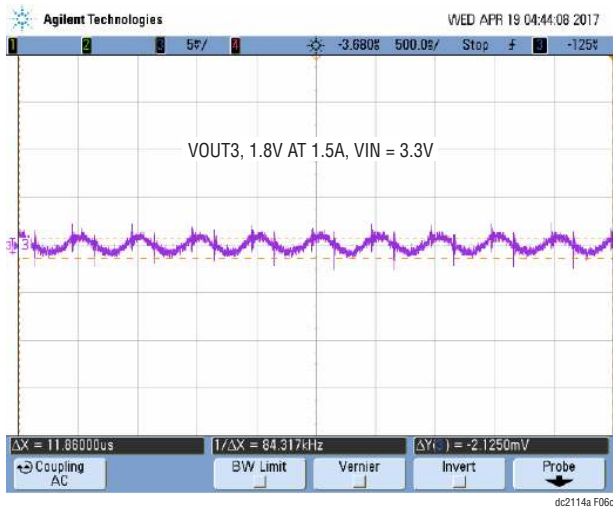

C. VOUT3 RIPPLE

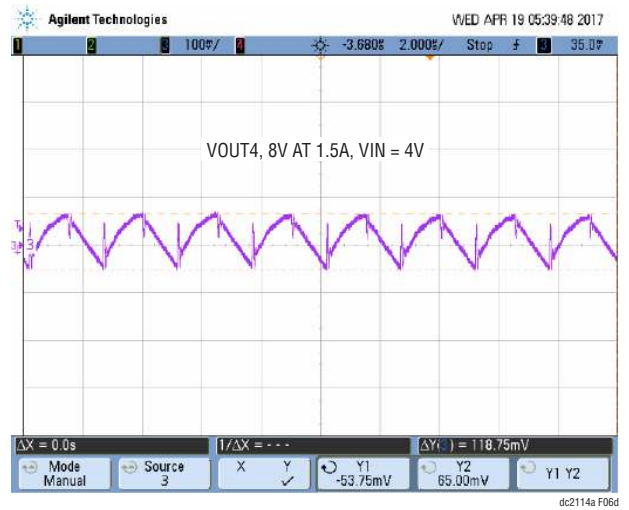

D. VOUT4 RIPPLE

Figure 6. LT8603 Output Ripples at VOUT1, VOUT2, VOUT3, VOUT4

PARTS LIST

ITEM	QTY	REFERENCE	PART DESCRIPTION	MANUFACTURER/PART NUMBER
Required Circuit Components				
1	1	CVIN	CAP, X5R 1 μ F 50V 10% 0603	TDK C1608X5R1H105KT
2	4	CVIN1, CVIN4, CVIN5, C6	CAP, X7R 4.7 μ F 50V 10% 1206	TDK C3216X7R1H475KT
3	1	CVIN2	CAP, X7R 10 μ F 50V 10% 1210	MURATA GRM32ER71H106KA12L
4	1	CVIN3	CAP, X5R 10 μ F 6.3V 20% 0603	MURATA GRM188R60J106ME47D
5	1	C1	CAP, ALUM 22 μ F 50V 10%	SUN ELECT. IND. 50CE22BSS
6	2	C7, C9	CAP, ALUM 47 μ F 50V 20%	SUN ELECT. IND. 50CE47BS
7	4	C8, C13, C19, C23	CAP, X7R 0.1 μ F 50V 10% 0603	MURATA GRM188R71H104KA93D
8	2	C11, C15	CAP, X7R 47nF 25V 20% 0603	AVX 06033C473MAT2A
9	1	C12	CAP, X5R 47 μ F 10V 10% 1206	MURATA GRM31CR61A476ME15L
10	2	C18, C22	CAP, X5R 100 μ F 6.3V 10% 1206	MURATA GRM31CR60J107KE39L
11	2	C20, C21	CAP, X7R 4.7 μ F 10V 10% 0805	MURATA GRM21BR71A475KA73K
12	1	C25	CAP, X7R 1500pF 25V 20% 0603	AVX 06033C152MAT2A
13	2	C26, C27	CAP, X5R 10 μ F 50V 10% 1206	MURATA GRM31CR61H106KA12L
14	5	C2, C3, C10, C17, C32	CAP, X7R 0.1 μ F 50V 10% 0402	MURATA GRM155R71H104KE14J
15	1	C29	CAP, COG 2.2pF 50V \pm 0.25pF 0603	MURATA GRM1885C1H2R2CA01D
16	1	C30	CAP, COG 4.7pF 50V \pm 0.25pF 0603	MURATA GRM1885C1H4R7CA01D
17	1	C31	CAP, COG 22pF 50V 5% 0603	MURATA GRM1885C1H220JA01D
18	1	D1	SCHOTTKY DIODE, POWER-DI-5	DIODE INC. PDS1040L-13
19	1	L1	INDUCTOR, 2.2 μ H XAL6030	COILCRAFT XAL6030-222ME
20	1	L2	INDUCTOR, 4.7 μ H XAL5030	COILCRAFT XAL5030-472ME
21	1	L3	INDUCTOR, 2.2 μ H XAL5030	COILCRAFT XAL5030-222ME
22	1	L4	INDUCTOR, 1.0 μ H NPIM42P	NIC COMP. CORP. NPIM42P1ROMTRF
23	1	L5	INDUCTOR, 0.22 μ H IHLP1212BZ-M11	VISHAY, IHLP1212BZERR22M11
24	1	Q1	MOSFET-N CHANNEL, 60V/25A LFPK	RENESAS RJK0651DPB-00-J5
25	1	R1	RES., CHIP, 0.006 Ω 1W, 1%, 0815	SUSUMU, RL3720WT-R006-F
26	4	R2, R3, R4, R5	RES., CHIP 24.9k 0.1W 1% 0603	VISHAY CRCW060324K9FKEA
27	1	R6	RES., CHIP 3.32M 0.1W 1% 0603	VISHAY CRCW06033M32FKEA
28	1	R7	RES., CHIP 365k 0.1W 1% 0603	VISHAY CRCW0603365KFKEA
29	1	R8	RES., CHIP 806k 0.1W 1% 0603	VISHAY CRCW0603806KFKEA
30	2	R9, R13	RES., CHIP 200k 0.1W 1% 0603	VISHAY CRCW0603200KFKEA
31	3	R11, R14, R19	RES., CHIP 100k 0.1W 1% 0603	VISHAY CRCW0603100KFKEA
32	1	R12	RES., CHIP 464k 0.1W 1% 0603	VISHAY CRCW0603464KFKEA
33	1	R15	RES., CHIP 1M 0.1W 1% 0603	VISHAY CRCW06031M00FKEA
34	1	R16	RES., CHIP 30.1k 0.1W 1% 0603	VISHAY CRCW060330K1FKEA
35	1	R17	RES., CHIP 187k 0.1W 1% 0603	VISHAY CRCW0603187KFKEA
36	1	R18	RES., CHIP 150k 0.1W 1% 0603	VISHAY CRCW0603150KFKEA
37	1	R20	RES., CHIP 2.49M 0.1W 1% 0603	VISHAY CRCW06032M49FKEA
38	1	R21	RES., CHIP 10.0k 0.1W 1% 0603	VISHAY CRCW060310K0FKEA
39	4	R22, R24, R27, R28	RES., JUMPER, CHIP, 0 Ω 0603	VISHAY CRCW06030000Z0EA
40	1	U1	BUCK REGULATOR QFN(40)(UJ)6MMX6MM	LINEAR TECH. CORP. LT8603EUJ
41	1	FB1	BEAD, 80 Ω , 4A, 1206	WURTH ELEKTRONIK, 742792150

DEMO MANUAL DC2114A

PARTS LIST

ITEM	QTY	REFERENCE	PART DESCRIPTION	MANUFACTURER/PART NUMBER
Additional Demo Board Circuit Components				
1	0	C14 (OPT)	CAP, 0603	
2	0	C28 (OPT)	CAP, 0603	
3	0	D2 (OPT)	DIODE, SOD523	
4	0	R10 (OPT)	RES., 0603	
5	0	R23 (OPT)	RES., 0603	
6	0	R25 (OPT)	RES., 0603	
7	0	R26 (OPT)	RES., 0603	
Hardware: For Demo Board Only				
1	20	E1, E2, E3, E4, E5, E6, E7, E8, E9, E10, E11, E12, E13, E14, E15, E16, E17, E18, E19, E20	TURRET, TESTPOINT	MILL MAX 2501-2-00-80-00-00-07-0
3	4	JP1, JP2, JP3, JP4	HEADERS, 3 PINS 2MM CTRS.	WURTH ELEKTRONIK, 62000311121
4	4	XJP1, XJP2, XJP3, XJP4	SHUNT, 2MM CTRS.	SAMTEC 2SN-BK-G
5	4	MH1-MH4	STAND-OFF, NYLON 0.25" TALL (SNAP ON)	WURTH ELECTRONIK, 702931000

SCHEMATIC DIAGRAM

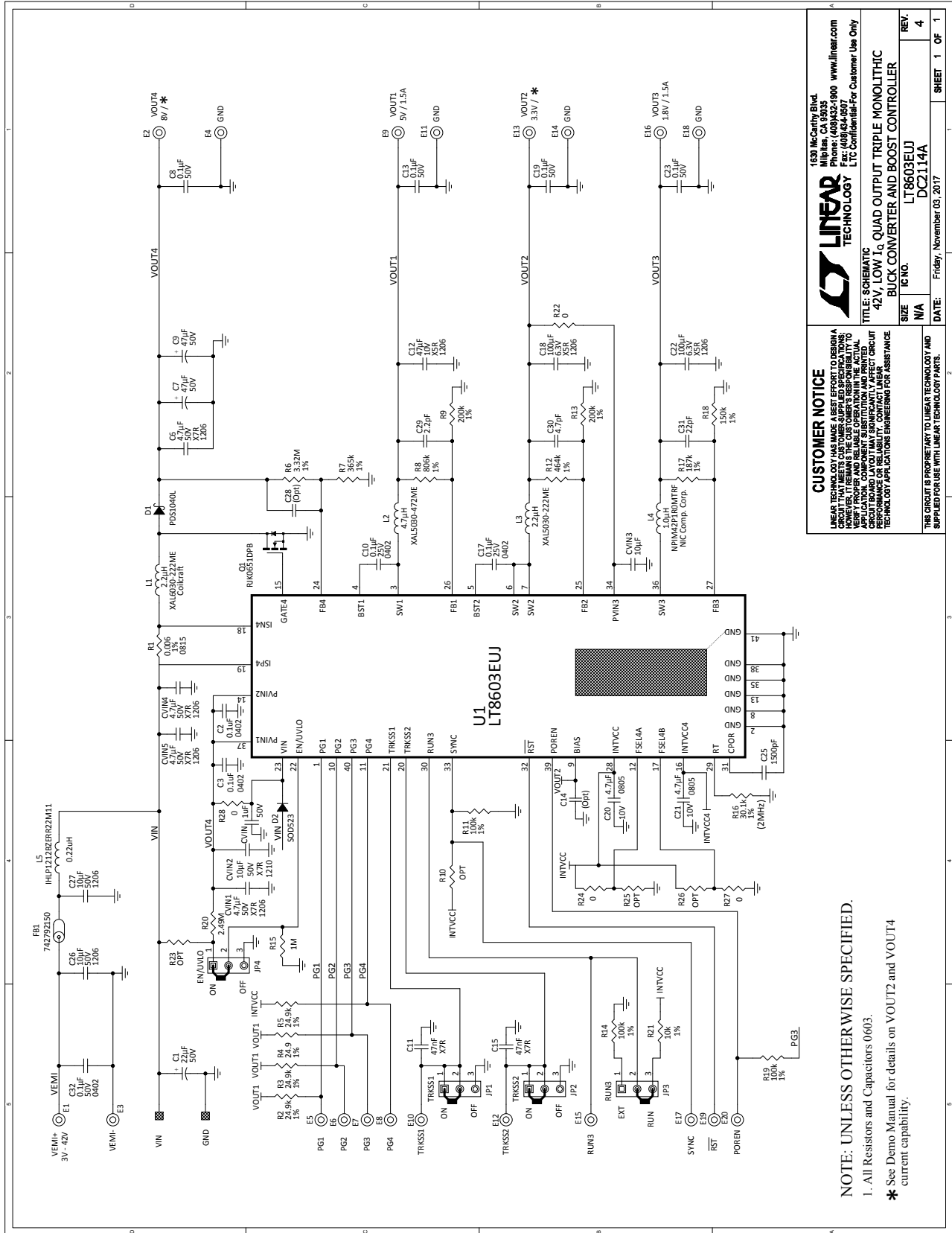

CUSTOMER NOTICE
 LINEAR TECHNOLOGY HAS MADE A BEST EFFORT TO DESIGN A CIRCUIT THAT MEETS CUSTOMER SUPPLIED SPECIFICATIONS. LINEAR TECHNOLOGY DOES NOT WARRANT THE ACTUAL PERFORMANCE OF ANY COMPONENTS IN THE CIRCUIT. APPLICATION, COMPONENT SUBSTITUTION AND PRINTED BOARD FABRICATION ARE THE RESPONSIBILITY OF THE CUSTOMER. LINEAR TECHNOLOGY APPLICATION ENGINEERING FOR ASSISTANCE.

1438 McGuffey Blvd
 Woburn, MA 01895
 Phone: (408) 332-1900 www.linear.com
 Fax: (408) 834-6507
 LTC Confidential-For Customer Use Only

LINEAR TECHNOLOGY

TITLE: SCHEMATIC
 42V, LOW I_o QUAD OUTPUT TRIPLE MONOLITHIC
 BUCK CONVERTER AND BOOST CONTROLLER

REV.	4
IC NO.	LT8603EUJ
DATE:	Friday, November 05, 2017

THIS CIRCUIT IS PROPRIETARY TO LINEAR TECHNOLOGY AND SUPPLIED FOR USE WITH LINEAR TECHNOLOGY PARTS.

NOTE: UNLESS OTHERWISE SPECIFIED.
 1. All Resistors and Capacitors 0603.
 * See Demo Manual for details on VOUT2 and VOUT4 current capability.



ESD Caution

ESD (electrostatic discharge) sensitive device. Charged devices and circuit boards can discharge without detection. Although this product features patented or proprietary protection circuitry, damage may occur on devices subjected to high energy ESD. Therefore, proper ESD precautions should be taken to avoid performance degradation or loss of functionality.

Legal Terms and Conditions

By using the evaluation board discussed herein (together with any tools, components documentation or support materials, the "Evaluation Board"), you are agreeing to be bound by the terms and conditions set forth below ("Agreement") unless you have purchased the Evaluation Board, in which case the Analog Devices Standard Terms and Conditions of Sale shall govern. Do not use the Evaluation Board until you have read and agreed to the Agreement. Your use of the Evaluation Board shall signify your acceptance of the Agreement. This Agreement is made by and between you ("Customer") and Analog Devices, Inc. ("ADI"), with its principal place of business at One Technology Way, Norwood, MA 02062, USA. Subject to the terms and conditions of the Agreement, ADI hereby grants to Customer a free, limited, personal, temporary, non-exclusive, non-sublicensable, non-transferable license to use the Evaluation Board FOR EVALUATION PURPOSES ONLY. Customer understands and agrees that the Evaluation Board is provided for the sole and exclusive purpose referenced above, and agrees not to use the Evaluation Board for any other purpose. Furthermore, the license granted is expressly made subject to the following additional limitations: Customer shall not (i) rent, lease, display, sell, transfer, assign, sublicense, or distribute the Evaluation Board; and (ii) permit any Third Party to access the Evaluation Board. As used herein, the term "Third Party" includes any entity other than ADI, Customer, their employees, affiliates and in-house consultants. The Evaluation Board is NOT sold to Customer; all rights not expressly granted herein, including ownership of the Evaluation Board, are reserved by ADI. CONFIDENTIALITY. This Agreement and the Evaluation Board shall all be considered the confidential and proprietary information of ADI. Customer may not disclose or transfer any portion of the Evaluation Board to any other party for any reason. Upon discontinuation of use of the Evaluation Board or termination of this Agreement, Customer agrees to promptly return the Evaluation Board to ADI. ADDITIONAL RESTRICTIONS. Customer may not disassemble, decompile or reverse engineer chips on the Evaluation Board. Customer shall inform ADI of any occurred damages or any modifications or alterations it makes to the Evaluation Board, including but not limited to soldering or any other activity that affects the material content of the Evaluation Board. Modifications to the Evaluation Board must comply with applicable law, including but not limited to the RoHS Directive. TERMINATION. ADI may terminate this Agreement at any time upon giving written notice to Customer. Customer agrees to return to ADI the Evaluation Board at that time. LIMITATION OF LIABILITY. THE EVALUATION BOARD PROVIDED HEREUNDER IS PROVIDED "AS IS" AND ADI MAKES NO WARRANTIES OR REPRESENTATIONS OF ANY KIND WITH RESPECT TO IT. ADI SPECIFICALLY DISCLAIMS ANY REPRESENTATIONS, ENDORSEMENTS, GUARANTEES, OR WARRANTIES, EXPRESS OR IMPLIED, RELATED TO THE EVALUATION BOARD INCLUDING, BUT NOT LIMITED TO, THE IMPLIED WARRANTY OF MERCHANTABILITY, TITLE, FITNESS FOR A PARTICULAR PURPOSE OR NON-INFRINGEMENT OF INTELLECTUAL PROPERTY RIGHTS. IN NO EVENT WILL ADI AND ITS LICENSORS BE LIABLE FOR ANY INCIDENTAL, SPECIAL, INDIRECT, OR CONSEQUENTIAL DAMAGES RESULTING FROM CUSTOMER'S POSSESSION OR USE OF THE EVALUATION BOARD, INCLUDING BUT NOT LIMITED TO LOST PROFITS, DELAY COSTS, LABOR COSTS OR LOSS OF GOODWILL. ADI'S TOTAL LIABILITY FROM ANY AND ALL CAUSES SHALL BE LIMITED TO THE AMOUNT OF ONE HUNDRED US DOLLARS (\$100.00). EXPORT. Customer agrees that it will not directly or indirectly export the Evaluation Board to another country, and that it will comply with all applicable United States federal laws and regulations relating to exports. GOVERNING LAW. This Agreement shall be governed by and construed in accordance with the substantive laws of the Commonwealth of Massachusetts (excluding conflict of law rules). Any legal action regarding this Agreement will be heard in the state or federal courts having jurisdiction in Suffolk County, Massachusetts, and Customer hereby submits to the personal jurisdiction and venue of such courts. The United Nations Convention on Contracts for the International Sale of Goods shall not apply to this Agreement and is expressly disclaimed.