

HTS - SERIES

BUL86261

REV. A

ASSEMBLY INSTRUCTIONS FOR HTS - HME TOP PANEL

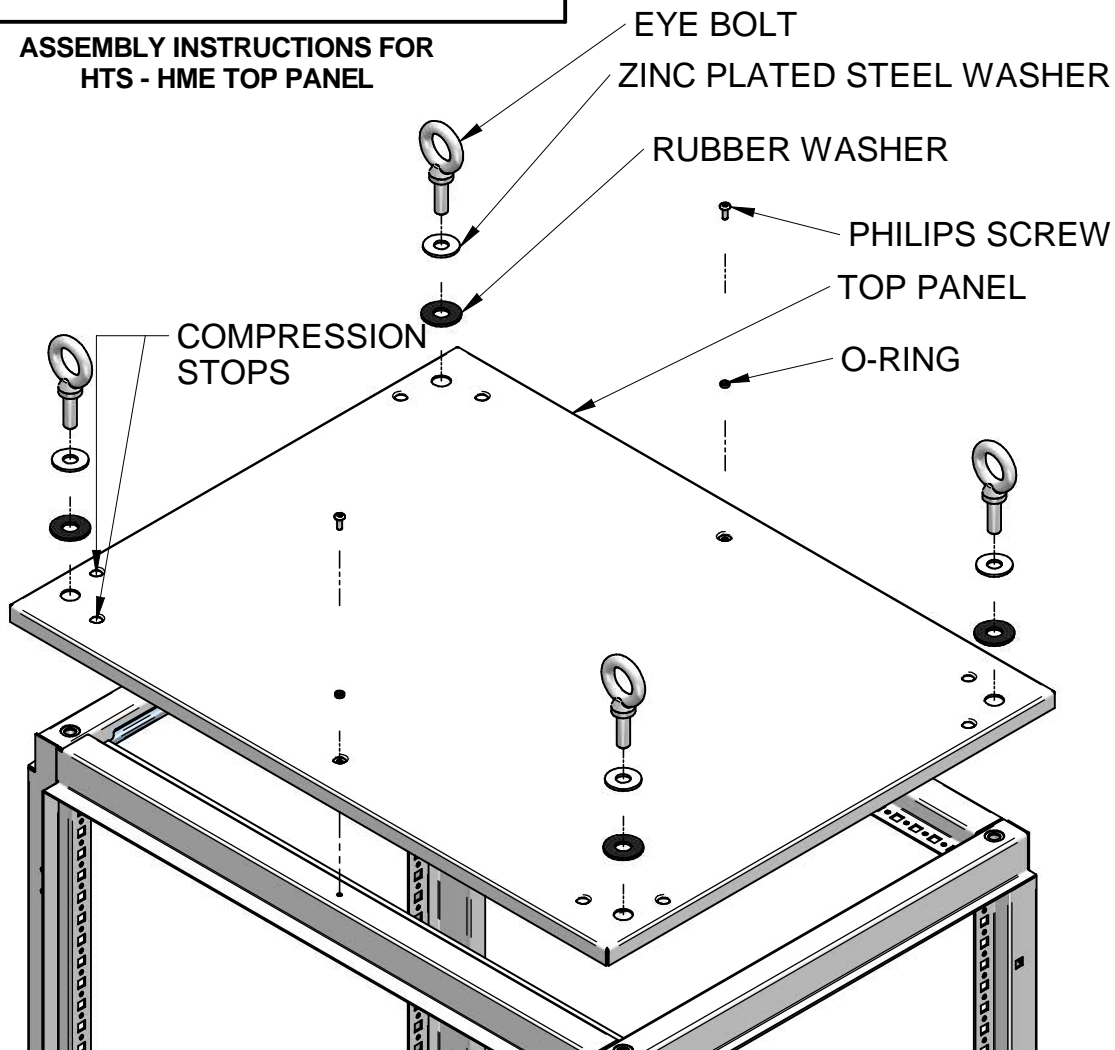

Removal Instructions:

- A) Loosen eye bolts (May require the use of a screwdriver or a bar to get it started). Larger top panels have a thread rolling screw in the center that needs to be removed as well.
- B) Loosen and remove self-tapping screws and O-rings.
- C) Lift top panel off.

Installation Instructions:

- A) Line holes on top panel up with holes on top of the frame.
- B) Install eye bolts with washers and tighten down so compression stop touches top frame. Also install center thread rolling screw if needed.

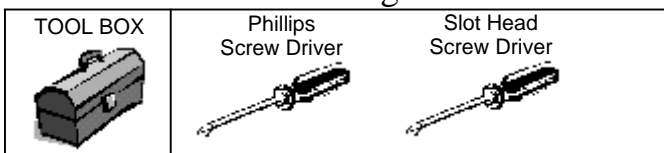

 **HAMMOND
MANUFACTURING™**
www.hammondmfg.com