

REVISION HISTORY			
REV	DESCRIPTION	DATE	APPROVED
B	DCN 50232	10/20	BNK

PRODUCT DATA DRAWING

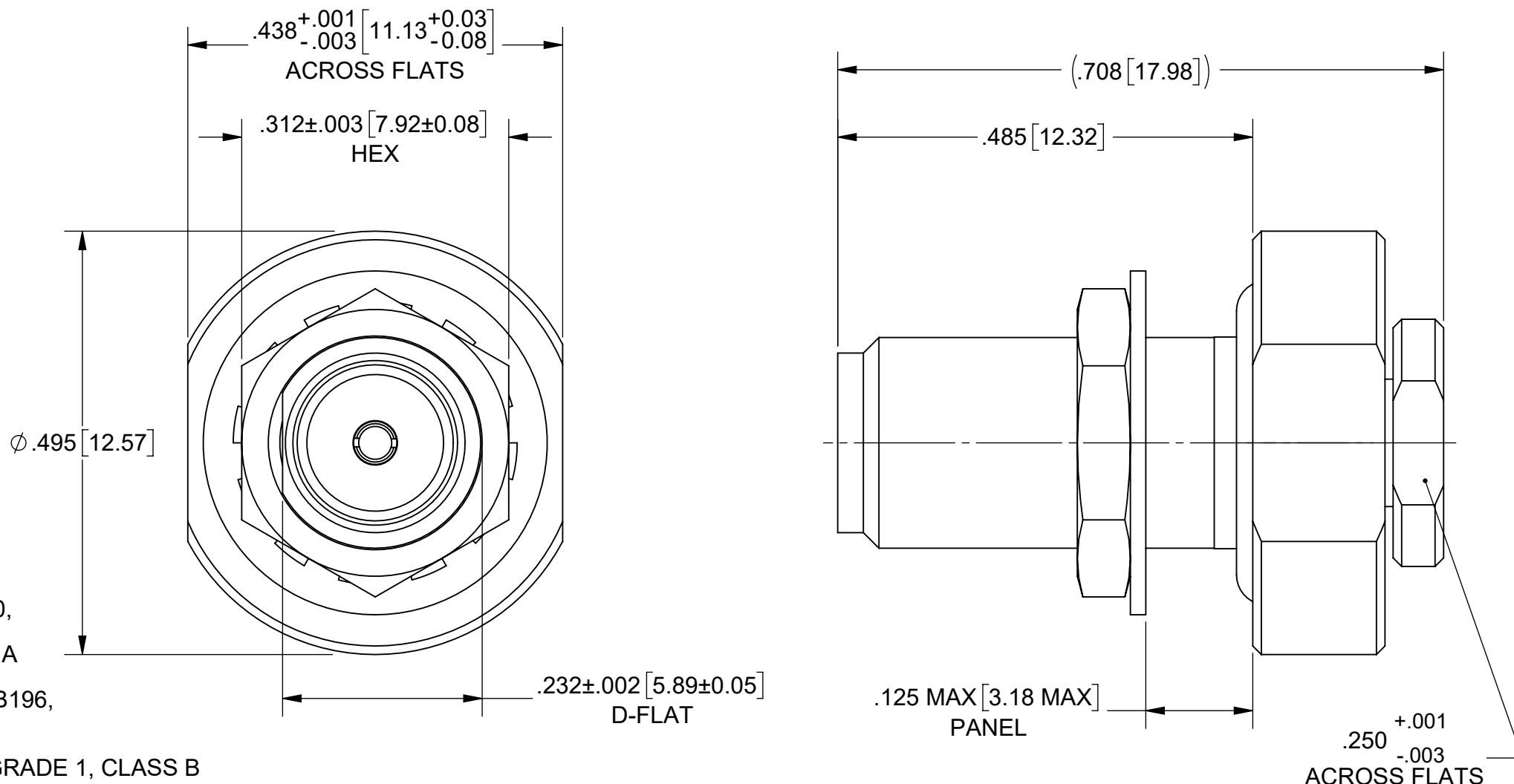
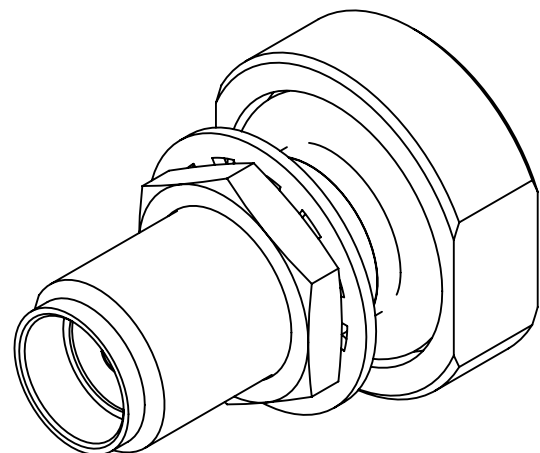

MATERIAL:

BODY, INSERT,
CLAMP NUT, &
HEX NUT:

STAINLESS STEEL PER AMS-5640,
ALLOY UNS S30300, TYPE 1;
OR ASTM A582 TYPE 303, COND. A

FERRULE
CONTACT:

BERYLLIUM COPPER PER ASTM B196,
ALLOY No. UNS C17300, TD04

INSULATOR:

PTFE PER ASTM D1710, TYPE I, GRADE 1, CLASS B

O-RING:

SILICONE RUBBER PER A-A-59588,
CLASS 2B, GRADE 60/70

LOCKWASHER:

300 SERIES STAINLESS STEEL

FINISH:

BODY, INSERT,
CLAMP NUT, &
HEX NUT:

PASSIVATED PER AMS-2700

FERRULE &
CONTACT:

GOLD PER ASTM B488, TYPE II,
CODE C, CLASS 0.76, OVER NICKEL
PER AMS-QQ-N-290, CLASS 1, .00005" MIN.

LOCKWASHER:

PASSIVATED

PERFORMANCE:

IMPEDANCE:
FREQ. RANGE:

50 OHMS
DC TO 18.0 GHz.

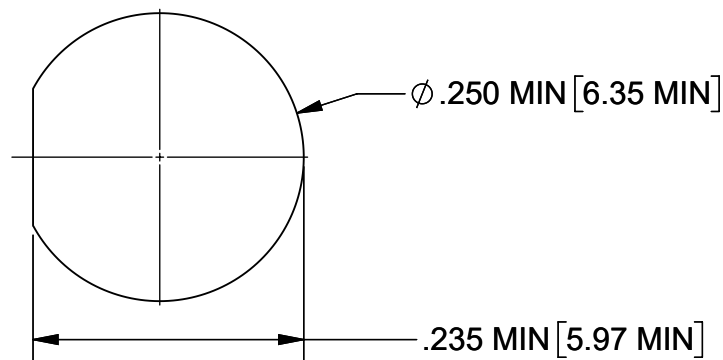

RECOMMENDED MOUNTING HOLE

MATERIAL: SEE NOTES	DIMENSIONS ARE IN INCHES TOLERANCES: FRACTIONAL: ±1/64 ANGULAR: X° ±1'0" X°X' ±15'	UNLESS OTHERWISE SPECIFIED 1) ALL DIMENSIONS ARE IN INCHES (MILLIMETERS) 2) ALL DIMENSIONS ARE AFTER PLATING. 3) BREAK CORNERS & EDGES .005 R. MAX. 4) CHAM. 1ST & LAST THREADS. 5) SURFACE ROUGHNESS 63-MIL-STD-10. 6) DIA.'S ON COMMON CENTERS TO BE CONCENTRIC WITHIN .005 T.I.R. 7) REMOVE ALL BURRS	 www.svmicrowave.com TITLE: SMA STR. F CONNECTOR FOR STANDARD FLEXTRA CABLE
FINISH: SEE NOTES	DECIMAL: .X ±.030 .XX ±.010 .XXX ±.005	INTERPRET DIMENSIONS AND TOLERANCES PER ASME Y14.5M - 1994	
SURFACE AREA: N/A	THIRD ANGLE PROJECTION	DRAWN: MEB 10/28/04	SIZE DWG. NO. B 2944-6001
<p>PROPRIETARY</p> <p>THE INFORMATION CONTAINED IN THIS DRAWING IS THE SOLE PROPERTY OF SV MICROWAVE, INC. ANY REPRODUCTION IN PART OR AS A WHOLE WITHOUT THE WRITTEN PERMISSION OF SV MICROWAVE, INC IS PROHIBITED.</p>		CHECKED: VMJ 10/28/04	SCALE: 6:1
		APPROVED: VMJ 10/28/04	SHEET 1 OF 1