

©2008 CARCLO  
ALL DIMENSIONS IN mm

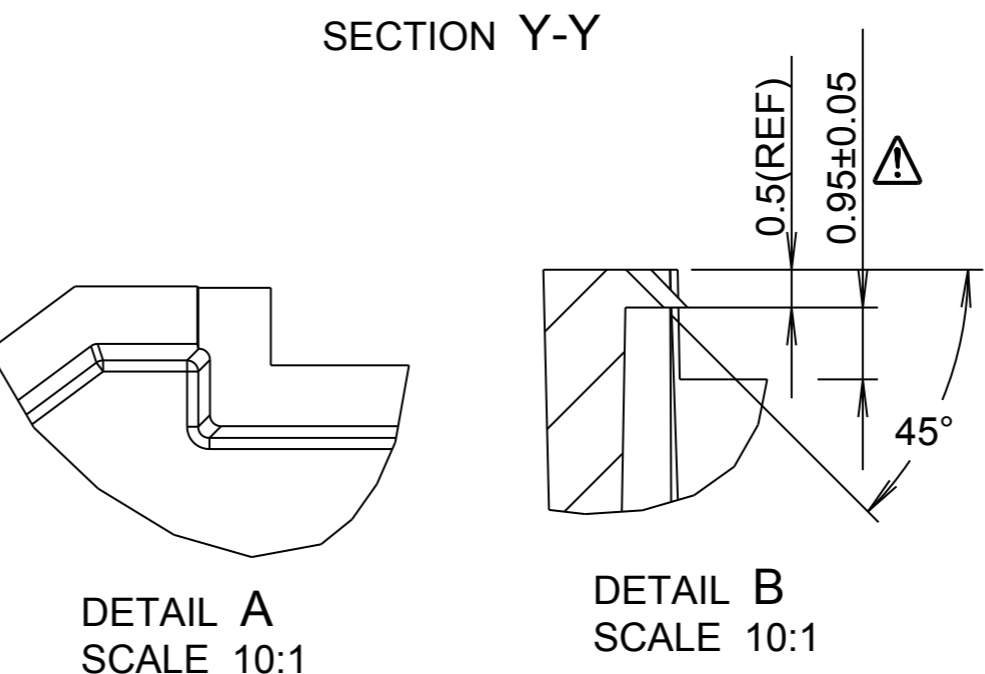

SECTION X-X  
DETAIL A SCALE 10:1  
DETAIL B SCALE 10:1

- NOTES:-  
1. MATERIAL: SEE TABLE  
2. FINISH: GOOD POLISH ALL OVER  
3. GEN. WALL THK. 1mm  
4. GEN DRAFT ANGLE 2 DEG.

⚠ DENOTES CRITICAL DIMENSION FOR INSPECTION

ISS.	DATE	E.C.N.	DESCRIPTION
1	20-Oct-06		FIRST ISSUE
2	19-Jan-09	01/09/1238	WIRING SLOTS REMOVED



CARCLO TECHNICAL PLASTICS (SLOUGH)  
111 BUCKINGHAM AVE, SLOUGH  
SL1 4PF, ENGLAND  
TEL: +44 1753 575011 FAX: +44 1753 811359  
email: design@carclo-optics.com

GENERAL TOLERANCES (UNLESS STATED)

LINEAR	ANGULAR
X +/- 0.25	X +/- 1°
X.X +/- 0.1	X.X +/- 0.5°
X.XX +/- 0.05	X.XX +/- 0.1°

CUSTOMER  
CARCLO

TITLE  
CREE HOLDER FOR 20MM OPTIC  
WITH 1.4MM OFFSET FOCUS

DRAWN MKI DATE 20-Oct-06

CHK'D DATE

APP'D DATE

SCALE 4:1 CARCLO PART No. SEE TABLE

PART No.	DESCRIPTION
10205	BLACK POLYCARBONATE
10206	CLEAR POLYCARBONATE
10207	WHITE POLYCARBONATE

SIZE A3 CARCLO DRG. No. 60435 SHEET 1 OF 1