



Main

Range of Product	Modicon ABE7
Product or Component Type	Solid state input relay sub-base
[Us] rated supply voltage	110/130 V AC 50/60 Hz sensor end) 24 V DC PLC end)
Number of Channels	16
Number of terminal per channel	2
Connections - terminals	Screw type terminals, 1 x 0.09...1 x 1.5 mm ² , 0.00... 0.00 in ² (0.09...1.5 mm ²) AWG 28...AWG 16) flexible with cable end Screw type terminals, 1 x 0.14...1 x 2.5 mm ² , 0.00... 0.00 in ² (0.14...2.5 mm ²) AWG 26...AWG 12) solid Screw type terminals, 1 x 0.14...1 x 2.5 mm ² , 0.00... 0.00 in ² (0.14...2.5 mm ²) AWG 26...AWG 14) flexible without cable end Screw type terminals, 2 x 0.09...2 x 0.75 mm ² , 0.00...0.00 in ² (0.09...0.75 mm ²) AWG 28...AWG 20) flexible with cable end Screw type terminals, 2 x 0.2...2 x 2.5 mm ² , 0.00... 0.00 in ² (0.2...2.5 mm ²) AWG 24...AWG 14) solid

Complementary

Terminal block type	Removable
Supply voltage limits	19...30 V DC PLC end)IEC 61131-2
Isolation PLC/operative part	Yes
Protection type	Internal fuse 1 A 5 x 20 mm fast blow PLC end Adjustable by external fuse fast blow sensor end
Fixing mode	By clips 35 mm symmetrical DIN rail) By screws solid plate with fixing kit)
Current per channel	0.0083 A
Current state 1 guaranteed	>= 5 mA sensor end)
Voltage state 1 guaranteed	>= 79 V sensor end
Maximum switching current	15 mA PLC end)
Minimum switching current	1 mA PLC end
Response time	<= 20 ms from state 0 to 1 <= 20 ms from state 1 to 0
Switching frequency	<= 25 Hz 50 %
[Uimp] rated impulse withstand voltage	2.5 kV IEC 60947-1
[Ui] rated insulation voltage	2000 V
Installation category	II IEC 60664-1
Tightening torque	5.31 lbf.in (0.6 N.m) flat Ø 3.5 mm
Width	8.11 in (206 mm)
Height	3.03 in (77 mm)
Depth	2.28 in (58 mm)
Net Weight	0.88 lb(US) (0.397 kg)

The information provided in this documentation contains general descriptions and/or technical characteristics of the performance of the products contained herein. This documentation is not intended as a substitute for and is not to be used for determining suitability or reliability of these products for specific user applications. It is the duty of any such user or integrator to perform the appropriate and complete risk analysis, evaluation and testing of the products with respect to the relevant specific application or use thereof. Neither Schneider Electric Industries SAS nor any of its affiliates or subsidiaries shall be responsible or liable for misuse of the information contained herein.

Environment

Dielectric strength	2000 V 50/60 Hz IEC 60947-1
Product Certifications	BV UL GL DNV CSA LROS (Lloyds register of shipping) EAC
Standards	IEC 61131-2 Type 1
IP degree of protection	IP2x conforming to IEC 60529
Resistance to incandescent wire	1382 °F (750 °C) IEC 60695-2-11
Shock resistance	15 gn 11 ms IEC 60068-2-27
Vibration resistance	2 gn 10...150 Hz)IEC 60068-2-6
Resistance to electrostatic discharge	4 KV contact) level 3 IEC 61000-4-2 8 kV air) level 3 IEC 61000-4-2
Resistance to radiated fields	9.14 V/m (10 V/m) 26000000...1000000000 Hz)IEC 61000-4-3 level 3
Resistance to fast transients	2 kV level 3 IEC 61000-4-4
Ambient air temperature for operation	23...140 °F (-5...60 °C) IEC 61131-2
Ambient air temperature for storage	-40...176 °F (-40...80 °C) IEC 61131-2
Pollution degree	2 IEC 60664-1

Ordering and shipping details

Category	22375 - INTERFACE MODULE(ABA,R,S)
Discount Schedule	CP2
GTIN	3389110546279
Nbr. of units in pkg.	1
Package weight(Lbs)	16.93 oz (480 g)
Returnability	No
Country of origin	LV

Packing Units

Unit Type of Package 1	PCE
Package 1 Height	2.76 in (7 cm)
Package 1 width	3.23 in (8.2 cm)
Package 1 Length	8.35 in (21.2 cm)
Unit Type of Package 2	S03
Number of Units in Package 2	16
Package 2 Weight	17.89 lb(US) (8.117 kg)
Package 2 Height	11.81 in (30 cm)
Package 2 width	11.81 in (30 cm)
Package 2 Length	15.75 in (40 cm)

Offer Sustainability

Sustainable offer status	Green Premium product
California proposition 65	WARNING: This product can expose you to chemicals including: Lead and lead compounds, which is known to the State of California to cause cancer and birth defects or other reproductive harm. For more information go to www.P65Warnings.ca.gov
REACH Regulation	 REACH Declaration
REACH free of SVHC	Yes
EU RoHS Directive	Pro-active compliance (Product out of EU RoHS legal scope)  EU RoHS Declaration
Mercury free	Yes
RoHS exemption information	 Yes
China RoHS Regulation	 China RoHS Declaration

Environmental Disclosure	Product Environmental Profile
Circularity Profile	End Of Life Information
WEEE	The product must be disposed on European Union markets following specific waste collection and never end up in rubbish bins.

Contractual warranty

Warranty	18 months
----------	-----------

Dimensions

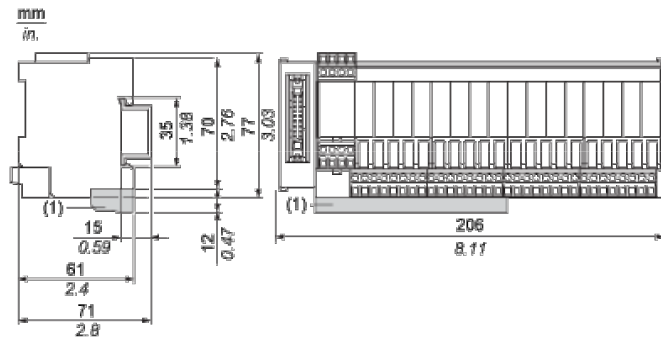

(1) ABE7BV20 / ABE7BV20E

Mounting

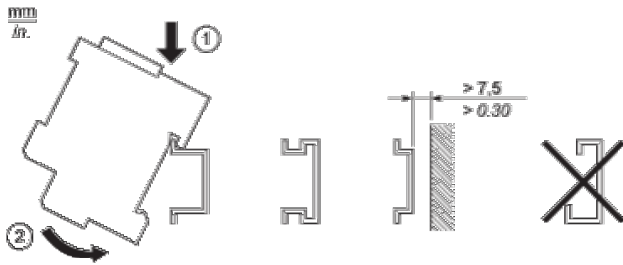

HE10 16 Channels

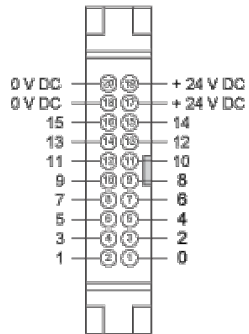

Wiring Diagram

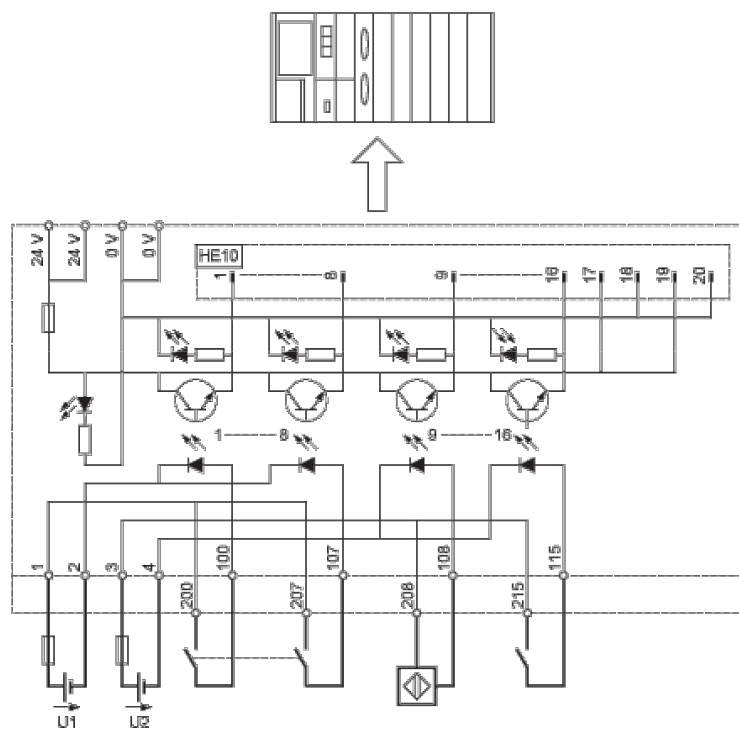

ABE7	U1, U2
S16E2B1 / E2B1E	24 VDC
S16E2E1 / E2E1E	48 VDC
S16E2E0 / E2E0E	48 VAC
S16E2F0 / E2F0E	115 VAC
S16E2M0 / E2M0E	230 VAC

Curves for Determining Cable Type and Length According to the Current

16-channel Sub-base

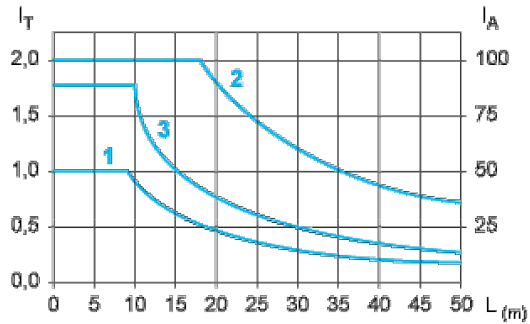

L Cable length

I_T Total current per sub base (A)

I_A Average current per channel (mA)

(1) TSXCDP••2 and ABFH20H••0 cables with c.s.a. 0.08 mm² (AWG 28).

(2) TSXCDP••3 cables with c.s.a. 0.34 mm² (AWG 22).

(3) Cables with c.s.a. 0.13 mm² (AWG 26).

The curves are given for a voltage drop of 1 V in the cable. For n volts tolerance, multiply the length determined from the graph by n.