



# Inventek Systems

Embedding Connectivity Everywhere

## Embedded Wi-Fi 802.11

b/g/n Applications Utilizing  
Leading-Edge Wi-Fi Technology



INVENTEK SYSTEMS

EMBEDDED WIRELESS SOLUTIONS

The IoT / Cloud Ready Solution



# Inventek Serial-to-Wi-Fi Portfolio



**All eS-WiFi (embedded Serial ) Wi-Fi modules have the following main features:**

- ◇ 802.11 a/b/g/n Wi-Fi protocol support based on Broadcom WICED Technology.
- ◇ Integrated TCP/IP Stack residing on Cortex ARM microcontroller.
- ◇ AT command set or Broadcom WICED Firmware
- ◇ Connects to any 8/16/32 bit host micro-computer.
- ◇ Simultaneous STA and Access Point
- ◇ Cloud connected options
- ◇ Host Interfaces include UART and SPI (USB for select modules).
- ◇ WEP, WPA, WPA2 and WPS



Part Number	Wi-Fi BT BLE NFC	Band GHZ	Micro	Host Interface	Antenna	Dimensions (mm)	Package	FCC/IC Approved
ISM4390-M3H-L44-ED	Wi-Fi	2.4	Cortex M3 (48 MHz)	UART-1Mbps +	Micro-strip or External	14.5 x 30	44-pin LGA	In Process
ISM90—L57	Wi-Fi	2.4	Cortex M3 (48 MHz)	UART-1Mbps +	None	10.5 x 10.5	57- pin LGA	No
ISM43362-M3G-L44-U	Wi-Fi	2.4	Cortex M3 (120MHz)	UART-1 Mbps, SPI- 5Mbps, USB HID	External - U.FL Connector	14.5 x 30	44-pin LGA	Yes
ISM43362-M3G-L44-E	Wi-Fi	2.4	Cortex M3 (120MHz)	UART-1 Mbps, SPI- 5Mbps, USB HID	Micro-strip Etched	14.5 x 30	44-pin LGA	Yes
ISM43340--M4G-L44-C	Wi-Fi BT BLE	2.4 & 5	Cortex M4 (168 MHz)	UART-1Mbps, SPI- 5Mbps	Chip or External	14.5 x 30	44-pin LGA	In Process
ISM43341--M4G-L44-C	Wi-Fi BLE BT NFC	2.4 & 5	Cortex M4 (168 MHz)	UART-1Mbps, SPI- 5Mbps	Chip or External	14.5 x 30	44-pin LGA	In Process



Design Today and upgrade to latest 802.11 standards in the same footprint !

Talk advantage of future features and lower cost solutions !

## **eS-WiFi USB with integrated TCP/IP stack**

Part Number	Wi-Fi Band	Host Interface	Antenna	Dimensions (mm)	Package
ISM43362-M3G-USB	2.4 GHz	USB HID 300 Kbps	Internal Stamped Metal	10 x 17 w/o USB Connector	USB Dongle



# Wi-Fi SIP Modules

**Inventek Systems offers Wi-Fi SIP modules for higher volume applications running a full Operating Systems**



- ◆ 802.11 a/b/g/n Wi-Fi SIP based on Broadcom Wi-Fi Technology.
- ◆ 72.2 Mbps for a single 802.11n stream
- ◆ Complete Drivers for Linux and Android Operating Systems
- ◆ IEEE 802.11n D7.0 (OFDM 72.2 Mbps in single stream with 20MHz, Short GI)
- ◆ IEEE 802.11g (OFDM 54 Mbps) and IEEE 802.11b (DSSS 11Mbps)
- ◆ IEEE 802.11b (DSSS 11Mbps)
- ◆ IEEE 802.11i (security)
- ◆ WPA™, WPA2™ (Wi-Fi Protected Access)
- ◆ 4 bit SDIO interface for WLAN
- ◆ 4-Wire Bluetooth co-existence handshake interface support.

Part Number	Wi-Fi BT BLE NFC	Band GHz	Host Inter- face	Drivers Avail- able	Antenna	Dimen- sions (mm)	Package	FCC/IC Approved
ISM43362-L36	Wi-Fi	2.4	SDIO	Linux, Android	Micro-strip or external	24.4 x 14.5	36-pin LGA	Yes
ISM43362-B81	Wi-Fi	2.4	SDIO	Linux, Android	None	8.1 x 8.6	81 pin BGA	No
ISM43340-L77	Wi-Fi BT, BLE	2.4 & 5	SDIO	Linux, Android	None	13.3x 14.5	77 pin LGA	No
ISM43341-L77	Wi-Fi BT, BLE, NFC	2.4 & 5	SDIO	Linux, Android	None	13.3x 14.5	77 pin LGA	No



## SIP DRIVERS BY PLATFORM

Kernel	Version	Distribution	BROADCOM BCM5892	TI SITARA	Atmel SAM9N12	Intel x86 (x32)	Intel x86 (x64)	Freescall IMX
Linux	3.x	Ubuntu	In development Q1 15	Available	Available	Available	Available	In develop- ment Q1 15
Linux	3.x	Angstrom	In development Q1 15	Available	Available	Available	Available	In develop- ment Q1 15
Linux	2.x	Fedora	In development Q1 15	Available	Available	Available	Available	In develop- ment Q1 15
Android	TBD	TBD	In development Q1 15	In develop- ment Q1 15	In develop- ment Q1 15	In develop- ment Q1 15	In develop- ment Q1 15	In develop- ment Q1 15



# Robust and Simple AT Commands (IWIN)



## Fast Time to Market

- ◆ OS Independent—No drivers required
- ◆ No need for extensive networking or WiFi knowledge
- ◆ Soft Access Point for Wi-Fi network connects in end products
- ◆ Direct Connect option allow for simple peer to peer network
- ◆ Cloud Agents Ported to run on eS-WiFi Modules

## Simple Commands

- ◆ Joining to network  
WiFi Security:  
WEP/WPA/WPA2-Personal  
Auto-connect on power up
- ◆ Scanning for networks
- ◆ Pinging
- ◆ Power Save Modes
- ◆ Making TCP or UDP connections
- ◆ Sending & Receiving Data Control of

## Only 8 AT Commands to send data ( IWIN )

### Joining a Network

- 1.C1=Inventek (Set SSID)
- 2.C2=hav3fun (Set Password )
- 3.C3=2 (Set Security Type)
- 4.C0 (Join Network )

**Four simple commands and your connected!**



### Creating a Connection

- 1.P2=5300 (Set TCP Local Port)
- 2.P5=1 (Start TCP Server)

### Sending & Receiving Data

1. S0\r48415645 (Send Data)
2. R0 (Receive Data) 48415645

## Production Ready IOT Solutions

### Connecting Anything, to Anyone, at Anytime

- Home Appliances
- HVAC Systems
- Energy Meters

–Medical Devices

–Sensors

–Consumer Devices

–Environmental Monitors.

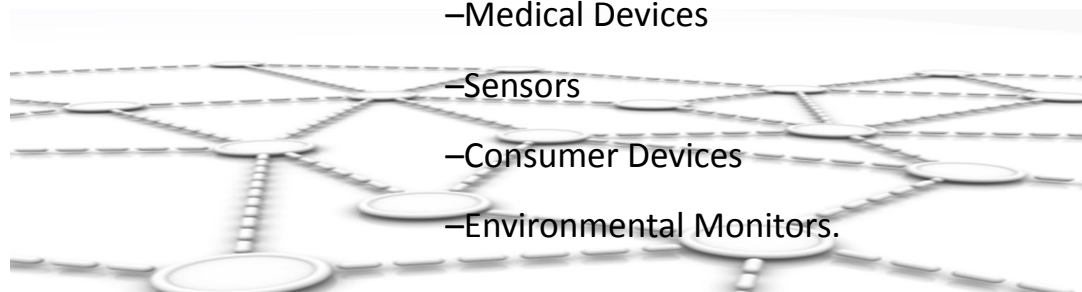



# Simply Connecting Embedded Devices



The Wi-Fi module hardware consists of an Cortex M3 host processor, integrated antenna and Broadcom Wi-Fi radio. The module has an USB, SPI and UART interfaces enabling connection in an embedded design. The Wi-Fi module requires no operating system and has a complete integrated TCP/IP Stack that only requires a simple AT command set to establish connectivity for any wireless product, minimizing development time, testing routines and certification.

## Typical Applications:

- PDA, Pocket PC, computing devices
- Building automation and smart energy control.
- Industrial sensing and remote monitoring.
- Warehousing, logistics and freight management
- PC and gaming peripherals
- Printers, scanners, alarm and video systems
- Medical applications
- Patient monitoring and remote diagnostics

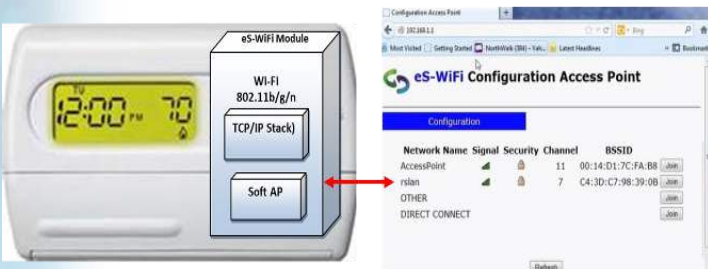

eS-WiFi in a Thermostat

## SoftAP Configuration:

SoftAP is Running on eS-WiFi in a thermostat. The SoftAP will be accessed by a iPad, PC or Smartphone as a web browser to configure the Thermostat as a client on a network.

## 6-8 Wires Interconnect:

eS-WiFi only requires six connections to integrate a UART (serial to Wi-Fi) 802.11 b/g/n Wi-Fi solution to your embedded device.

Complete with FCC certification

## ES-WIFI MODULE

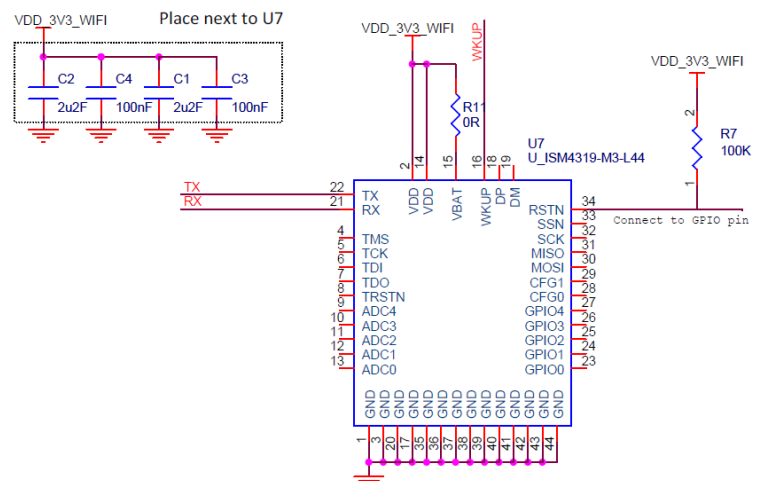



# Inventek integrates Cypress PSoC and Broadcom Wi-Fi for Embedded Device to Device Communication

## Wirelessly Managing the “health” of the system

Managing environmental sensors (e.g. temp, humidity, lighting, power supplies, system cooling in real-time, system communications, Providing simple user interface and debug ports, Managing system communications

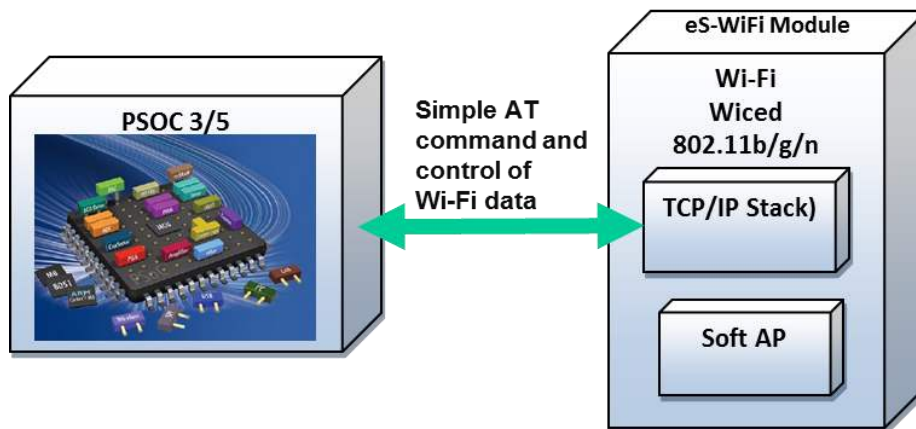

## Wirelessly Connect the “health” of the system to the Cloud

## Wirelessly Control the “health” of the system with your Smartphone

PSoC 3 and PSoC 5 are a true programmable embedded system-on-chip integrating configurable analog and digital peripheral functions, memory and a microcontroller on a single chip. A complete programmable embedded 802.11 b/g/n Wireless system design platform.

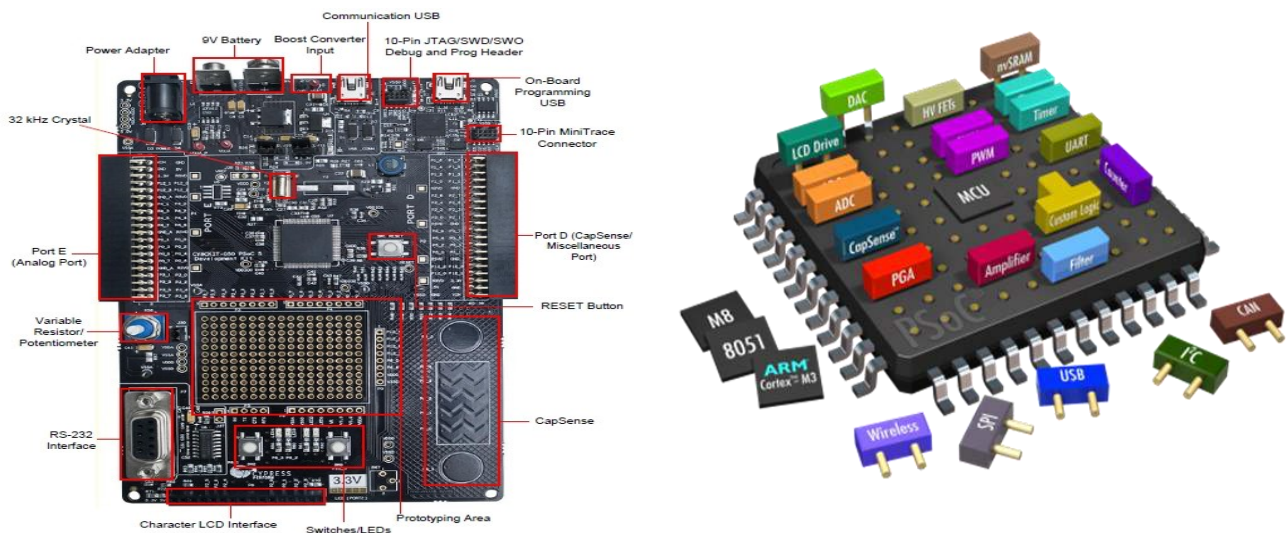

# Inventek Wi-Fi Evaluation Boards



## Inventek eS-WiFi Evaluation Boards

The Inventek evaluation boards support supports the family of eS-Wifi 802.11 Wi-Fi modules. The modules are designed with a complete integrated TCP/IP stack and come with a simple to use AT command set making embedded Wi-Fi into your device simple. The eS-Wifi has a family of footprint compatible modules Based on Broadcom's leading edge WI-Fi radio's. The Standard 44 pin Land Grid package allows simple migration for future cost reduction platforms.

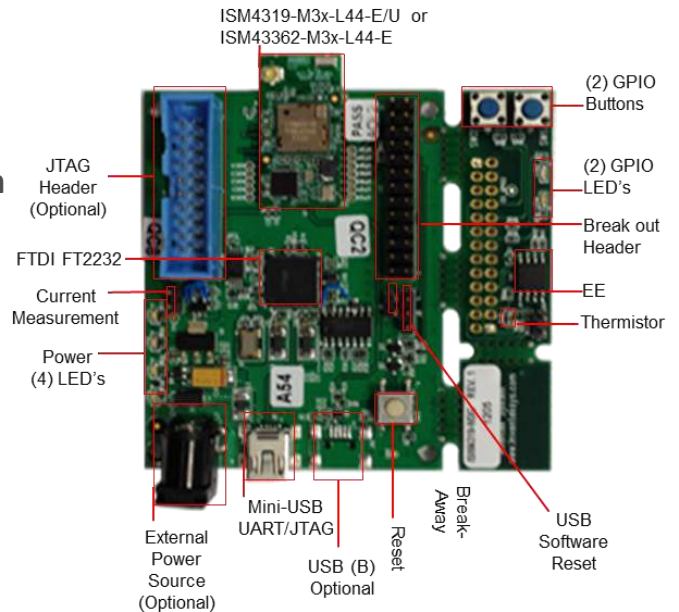

Part Number	Description	Availability
ISM43362-M3G-E-EVB	Serial to WiFi EVB , Broadcom BCM43362, STMF205, External Antenna ( Optional Ext.)	Production
ISM4390-M3H-ED-EVB	Serial to WiFi EVB , Broadcom BCM4390	Sampling -9/14
ISM43341-M4G-L44-E	Serial to WiFi EVB , Broadcom BCM4341, STMF405, Etched Antenna	Sampling-10/14

## Evaluation Boards Overview

### Cypress PSOC 3 or PSOC 5 Evaluation

The Inventek evaluation boards support supports the family of Cypress PSOC 3 and PSOC 5 EVB's. A simple custom PSOC module allows you to us the custom created PSOC creator to drag and drop a connection to any of the eS-Wi-Fi modules. The kit comes with a simple to use user guide, drivers and real life applications to create a wireless em-

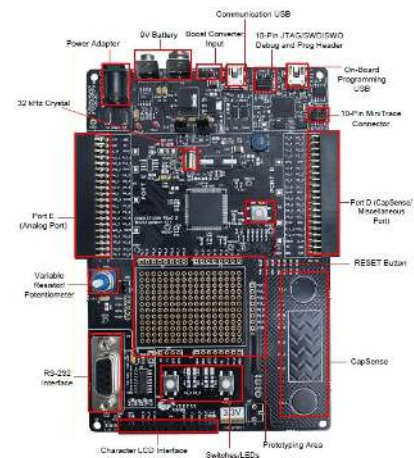

Part Number	Description	Availability
ISM4319-M3G-PSOC-EVB	Serial to WiFi EVB , Broadcom BCM4319, STMF205, Etched Antenna	Production



**CONTACT US** and start your Embedded Connected design today



INVENTEK SYSTEMS WIRELESS MODULE OFFERING:

LEADING THE SMART, TIME TO MARKET IoT REVOLUTION

## **Inventek Systems Corporate Office**

### **Contact**

Inventek Systems  
2 Republic Road  
Billerica Ma 01862  
978-667-1962

### **E-mail**

Sales@Inventeksys.com  
Engineering@Inventeksys.com  
www.Inventeksys.com

## **Inventek Systems Sales Representatives:**

<http://www.inventeksys.com/sales-reps/>

## **Inventek Channel Partners/ Distributors:**

America : Arrow Corporation, Avnet, Digi-Key, Macnica  
Japan : Macnica  
Canada : Arrow Corporation, Avnet, Digi-Key, Macnica, Motion Micro  
Mexico: Arrow Corporation  
Europe: Texim – Europe