

# DCmind Brushless Motor Datasheet

80 350 001  
SMI22 with CAN

Series  
80 350 SMI22 CAN

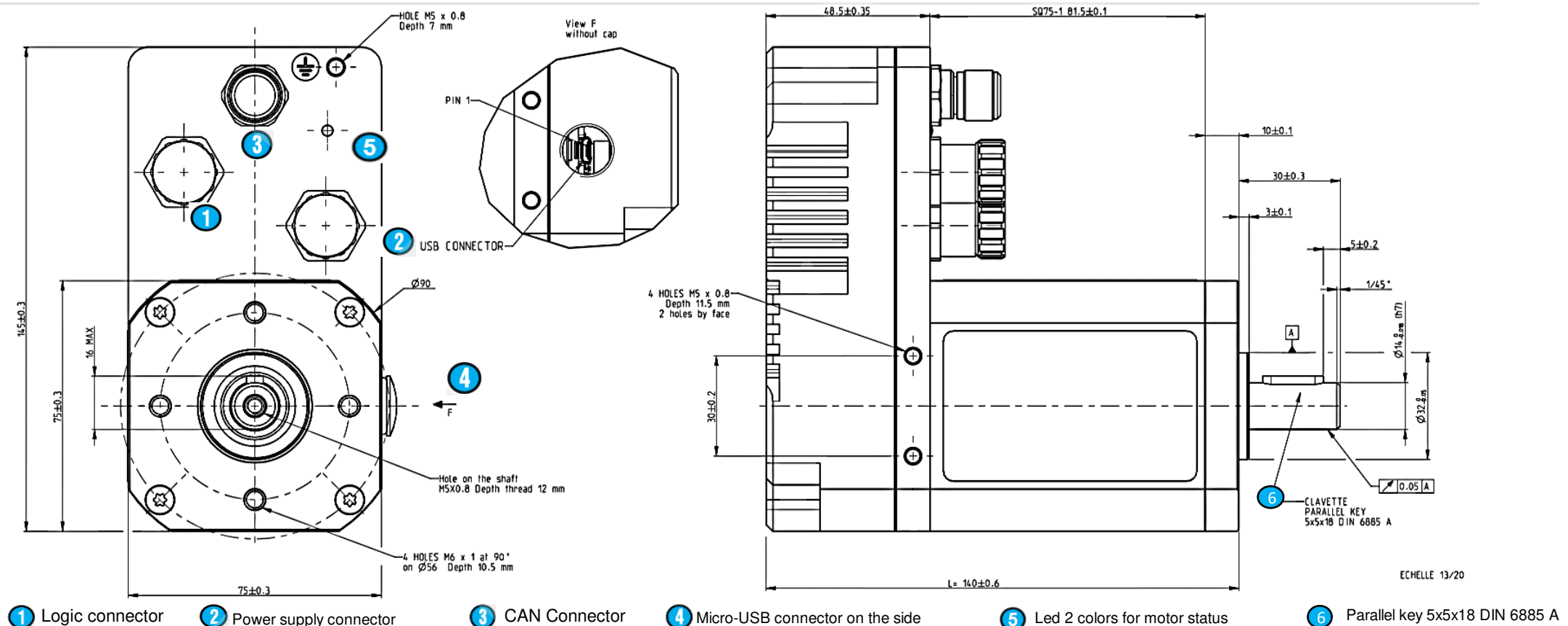

## General characteristics

Power supply		
Direct current voltage supply		✓
Nominal voltage range	Vdc	9 -> 75
Max. current	A	75

Motor characteristics (1)					
		12 Vdc	24 Vdc	32 Vdc	
<b>At no load</b>					
Max. output speed	rpm	1 700	3 230	4 500	
Current at the max output speed	A	1,1	1	2,4	
Standby current	mA	50	50	50	+/-10%
<b>At nominal</b>					
Speed	rpm	1 380	3 000	3 845	+/-10%
Torque	N.m	1	1	1	
Output power	W	145	314	400	+/-10%
Current	A	15,4	15,4	15,4	
Efficiency	%	78	85	82	
<b>At max. output power</b>					
Speed	rpm	1 000	2 310	3 100	
Torque (2)	N.m	2,5	2,5	2,5	
Output power	W	262	600	750	
Current	A	34,5	34,5	34,5	
Efficiency	%	60	74	68	
<b>At peak torque</b>					
Speed	rpm	1 000	2 310	3 100	
Torque	N.m	2,5	2,5	2,5	
Output power	W	262	605	750	
Current	A	34,5	34,5	34,5	

Others		
Life	h	20 000
Rotor inertia	gcm <sup>2</sup>	426
Rotor poles		8
Cogging torque	mNm	45
Weight	kg	2,4
Noise level	dBA	55

Connecting		
<b>Input/Output M16 connector - 18 pins</b>		
Optional logic supply	Pin N°	1
0 Volt		2
Input 6 (analogic 1)		3
Input 5 (analogic 2)		4
Input 1 (digital)		5
Input 2 (digital)		6
Input 3 (digital)		7
Input 4 (digital)		8
0 Volt		9
Output 1 (digital - PWM)		10
Output 2 (digital - PWM)		11
Output 3 (digital)		12
Output 4 (digital)		13
0 Volt		14
STO2 -		15
STO2 +		16
STO1 -		17
STO1 +		18
<b>Power supply M16 connector 3 pins</b>		
Output ballast	Pin N°	1
+VDC		2
0 Volt		3
<b>CAN M 12 Connector - 5 pins</b>		
Not connected	Pin N°	1 / 2
CAN_GND		3
CAN_H		4
CAN_L		5

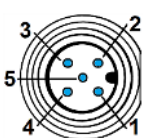
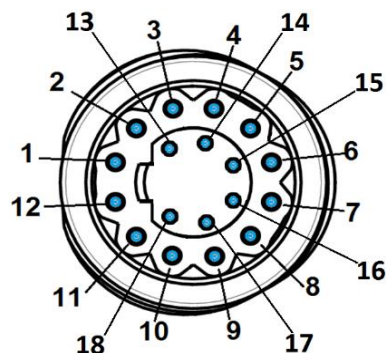

Drive		
Type	SMI22 CAN	
Built-in drive	✓	
Internal magnetic encoder	4096 pulses/rev	
Setting software on PC	DCmind soft+CANopen	
<b>Control</b>		
Position - speed - torque	✓	
4 quadrants	✓	
With regenerative energy absorber (3)	✓	
Type" Field Oriented Control"	✓	
<b>Security</b>		
Wrong polarity from power supply	✓	
Output shortcut	✓	
Input inverted	✓	
Low voltage	Vdc	<9
Overvoltage (4)	Vdc	> 75
Internal drive temperature protection	°C	110
Temperature drive allowing to restart	°C	90

Generic parameters			
Output shaft with ball bearings	✓		
2 Safe Torque Off inputs IEC61800-5-2/62061, ISO13849	✓		
Max. Radial force (16mm from front face)	N	140	
Max. axial force	N	47	
Temperature range	IEC60068-2-1/2	°C	-30 -> +70
Storage temperature		°C	-40 -> +80
Dielectric (1s/2mA)	UL1004-1	Vdc	1 955
Motor insulation	IEC60085	class	E
Salt spray	ISO9227	severity	48h
Degree of protection (output shaft not included)	IEC60529		IP67 + IP69
<b>EMC</b>			
Electrostatic Discharge	IEC61000-4-2	level	3
Radiated field	IEC61000-4-3	level	3
Electrical fast transient / burst test	IEC61000-4-4	level	3
Surge test	IEC61000-4-5	level	1
Conducted disturbances	IEC61000-4-6	level	3
Radiated emission	EN55022	class	B

Approvals		
ROHS	2011/65/CE	✓
EC		✓
UL		Pending
CAN Open	CIA DS 301/402	✓
<b>Communication</b>		
USB (Setting, monitoring)		Micro-USB B
CAN open: address - node ID (factory settings)		0x20
CAN open: baud rate (factory settings)		kbaud 1000

Notes	
Values without tolerances, are average production values.	
(1) Cold motor, 20 ° C ambient temperature, full speed, sinusoidal commutation	
(2) Max torque for continuous operation at 20 °C, decrease this value for higher ambient temperature	
(3) Ballast resistor to be added	
(4) Can be configured via DCmind soft+CANopen	

Additional information is available in the SQ75 product user manual and in the starter kit manual, available in [www.crouzet.com](http://www.crouzet.com)

Specifications subject to change without notice. Updated May 27th, 2019

## Drive electrical data

Running datas				
Parameters		Min.	Typical	Max.
Voltage power supply "Vdc"	Vdc	9	24	75
Current "I <sub>dc</sub> "	A	-	15	60
Standby power "Wo"	W	-	2	-
Voltage optional logic supply (see wiring diagram)	Vdc	9	-	75*

\* UL: maximum voltage supply: 36 Vdc

CAN Bus characteristics				
Parameters		Min.	Typical	Max.
CAN_L insulated	Vdc	0,5	1,5	2,25
CAN_H insulated	Vdc	2,75	3,5	4,5

## Accessories

Starter kit				
Part number	<b>79 513 105</b>			
Power/logic/CAN 3 m cables - Software - USB to Can Open adapter - CAN terminal resistor - CAN double connector				
Power supply cable	79 298 664	3m length	AWG18	
Input-Output cable	79 513 106	3m length	AWG24	
CAN cable M12	27 358 015	1m length	AWG26	

Input datas					
Parameters		Min.	Typical	Max.	
Input 1, 2, 3, 4	Impedance	kΩ	247	-	
	Low level	Vdc	-90	-	2,4
	High level	Vdc	4,5	-	90
Input 5, 6	Impedance	kΩ	159	-	
	Low level	Vdc	-90	-	2
	High level	Vdc	7,1	-	90
Inputs STO	Low level	Vdc	-2	-	4
	High level	Vdc	4,6	-	75

Output datas				
Parameters		Min.	Typical	Max.
Low level Output 1, 2, 3, 4	mVdc	-	-	10
High level Output 1, 2, 3, 4	Vdc	-	4,75	-
Max output current "I <sub>outmax</sub> "	mA	-	-	50
I <sub>sink</sub>	mA	-	-	600

## Speed-torque and current-torque curves

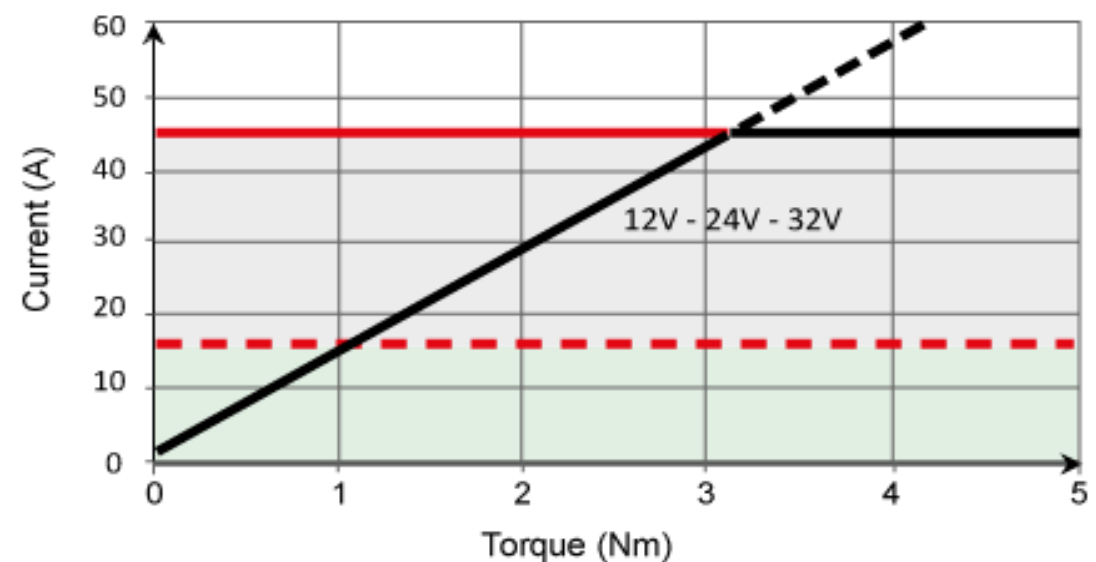
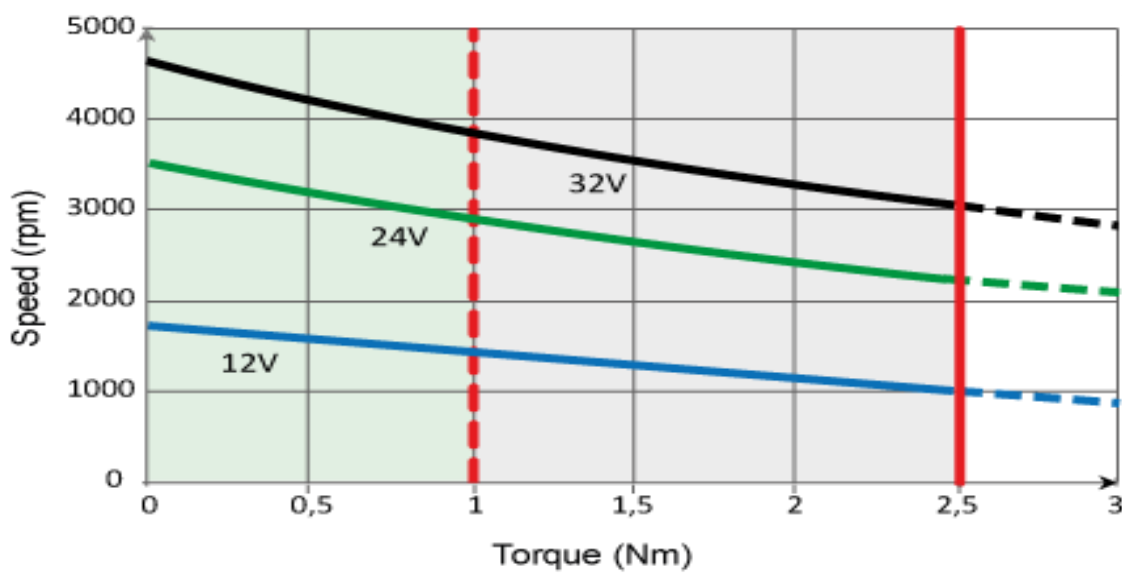

- - - Nominal      — Peak      Continuous running      Cycling

## Wiring

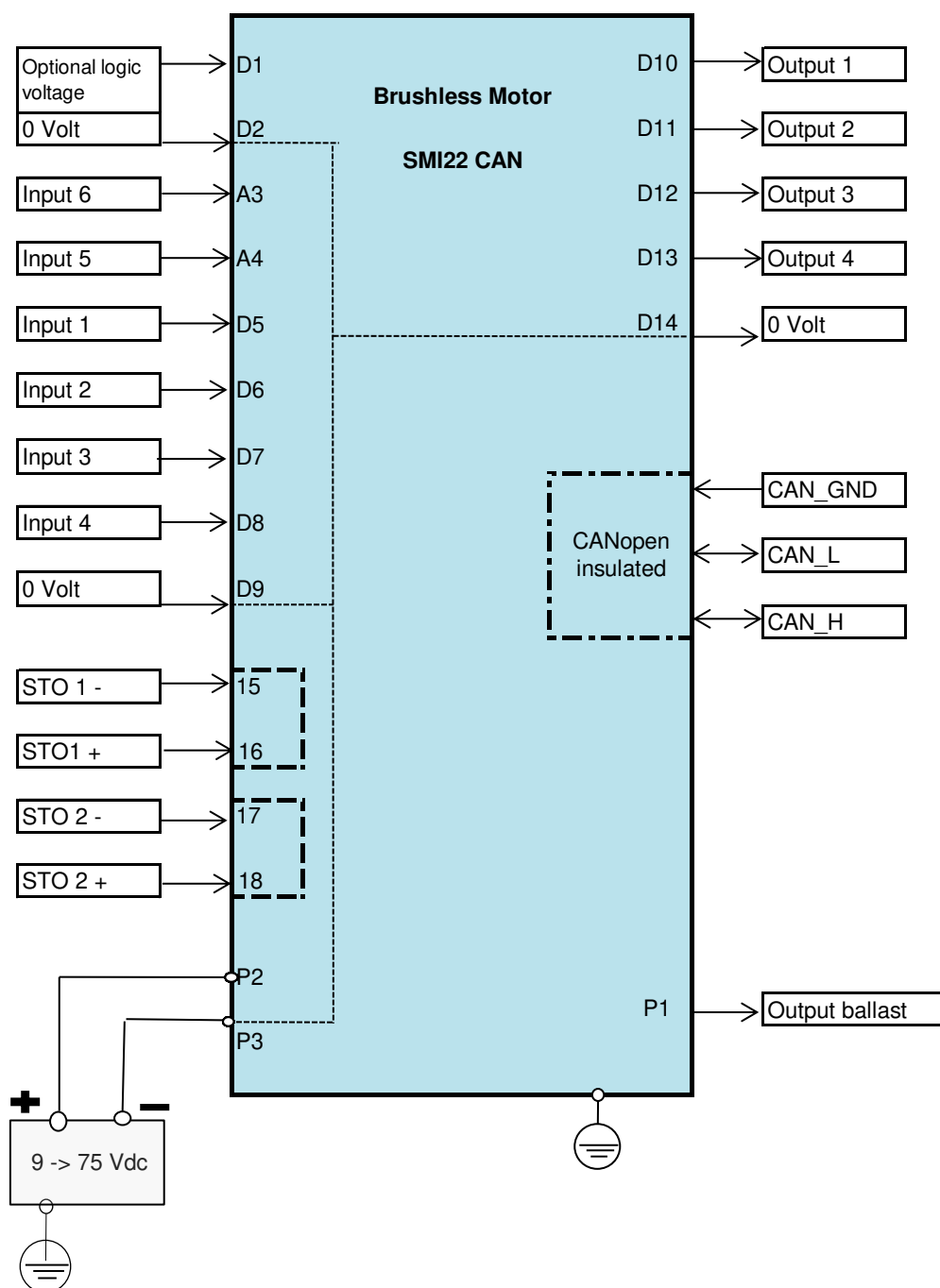

## Input equivalent circuit

Inputs 1, 2, 3, 4

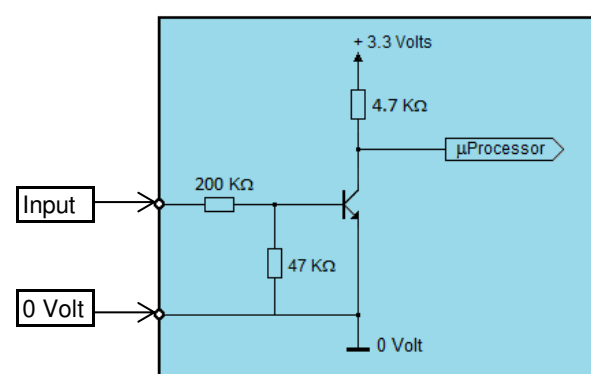

Inputs 5, 6

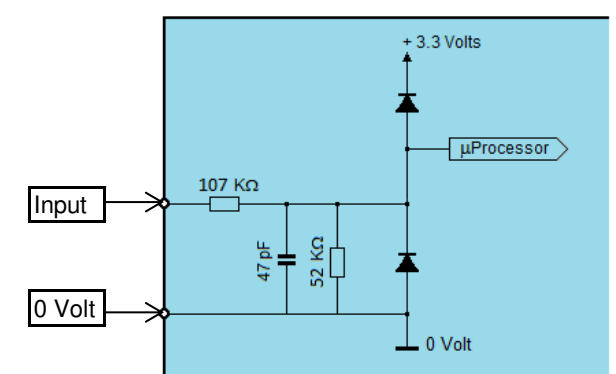

## Output equivalent circuit

Output 1,2,3,4

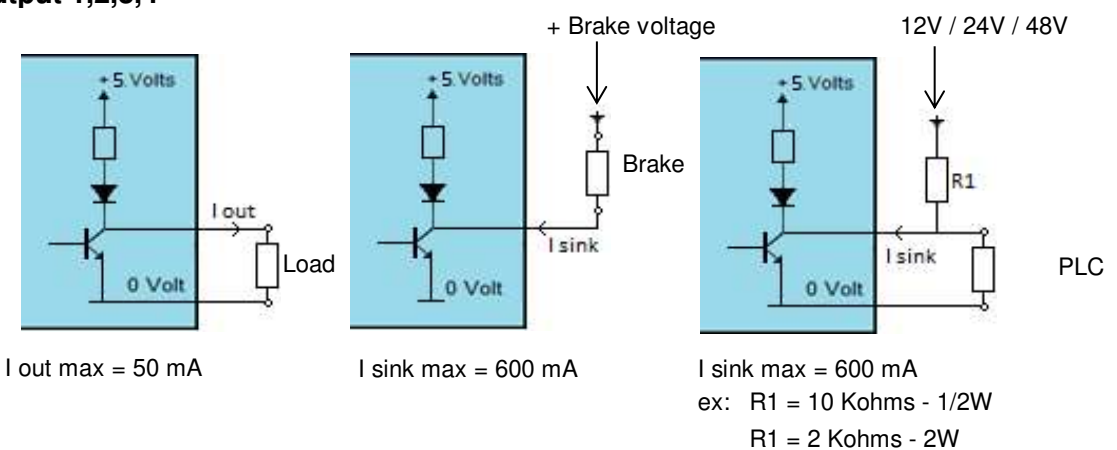

Output ballast

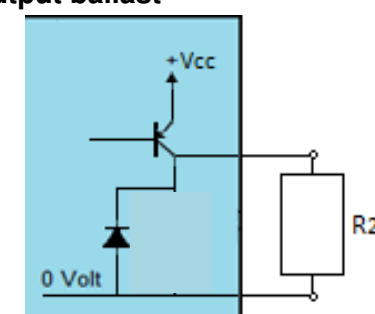

Regenerative energy created per inertia load creates over-voltage. In case of too high value, connect R2 resistor through ballast output and ground to absorb this energy. Typical R2 value is 2.2 Ω. Power value depends from machine inertia. Max. voltage can be set.

Specifications subject to change without notice. Updated May 27th, 2019