

- 1 POST TO WITHSTAND 13 NEWTONS (3 LBS) MINIMUM AXIAL FORCE IN BOTH DIRECTIONS SHOWN WITHOUT DISLODGING.
- 2 TOLERANCES APPLY TO SOLDER SIDE OF BOARD.
- 3 MEASURED AT SURFACE -A-
- 4 PLASTIC FLASH PERMITTED IN THIS AREA.
- 5 PARTS COMPLY WITH AMP SOLDERABILITY SPEC. NO. 109-11-2.
- 6 ONE HOLE MAY BE UNDERSIZED 1.30/1.17 [.051/.046] DIA. FOR ASSEMBLY RETENTION DURING WAVE SOLDERING.
- 7 MATERIAL: HEADER-THERMOPLASTIC POLYESTER GLASS-FILLED 94V-0 (NATURAL) POST-COPPER ALLOY (SEE NOTES 13 & 14 FOR PLATING)
- 8 COORDINATE DIMENSION APPLIES FROM CENTER OF ACTUAL FEATURE.
- 9 PLASTIC BURRS CAUSED BY CUT-OFF TOOLING ARE PERMITTED WITHIN THE MAXIMUM TOLERANCE ENVELOPE.
- 10 POST TO BE MEASURED WHEN STRIP IS HELD FLAT.
- 11 POST MUST WITHSTAND TWO 90° BENDS AGAINST EXTRUSION WITHOUT BREAKING.
- 12 DIMENSION SHOULD BE 4.45 [.175] MIN WHEN MATING WITH A MTA-156 CONNECTOR ASSEMBLY OR A SL-156 CONNECTOR ASSEMBLY.
- 13 PLATING: GOLD PLATE AREA, 0.00076[.000030] GOLD OR 0.00008[.000003] MIN GOLD FLASH OVER 0.00068[.000027] PALLADIUM NICKEL, PER TE CONNECTIVITY'S DISCRETION, ALL SIDES, OVER NICKEL UNDERPLATE, 0.00127[.000050] MIN, ALL SIDES AND ENTIRE LENGTH OF POST.
- 14 PLATING: BRIGHT TIN/LEAD (93/7) PLATE AREA, 0.00381-0.00889 [.000150-.000350] THICK, ALL FOUR SIDES 3.18 [.125] MINIMUM FOR -2 THRU -24. MATTE TIN PLATE AREA 0.00381-0.00889 [.000150-.000350] THICK ALL FOUR SIDES, 3.18 [.125] FOR -32 THRU -54.
- 15 OBSOLETE PARTS: OBSOLETE CIS STREAMLINING PER D.RENAUD/D.SINISI
- 16 OBSOLETE PARTS

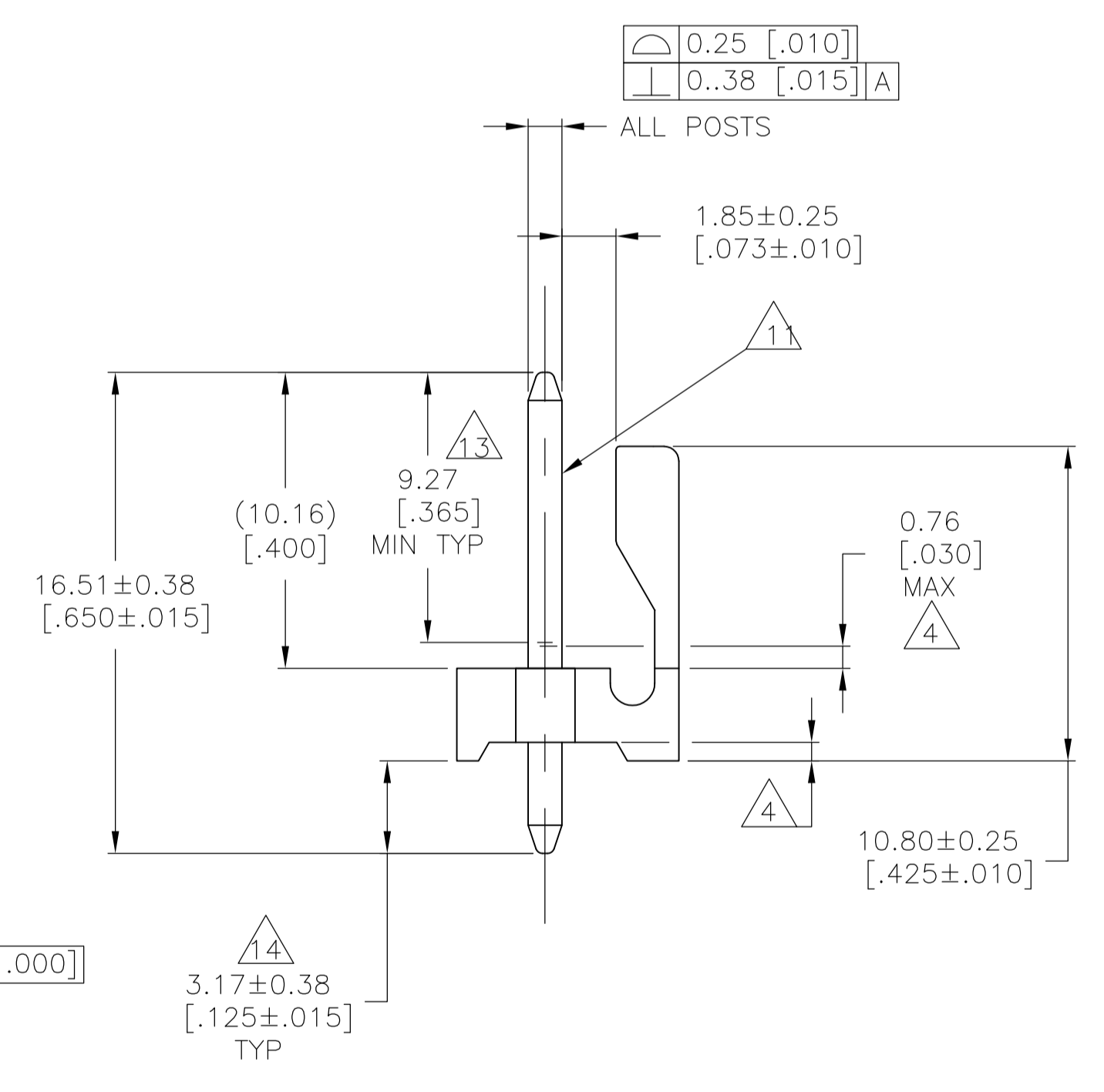
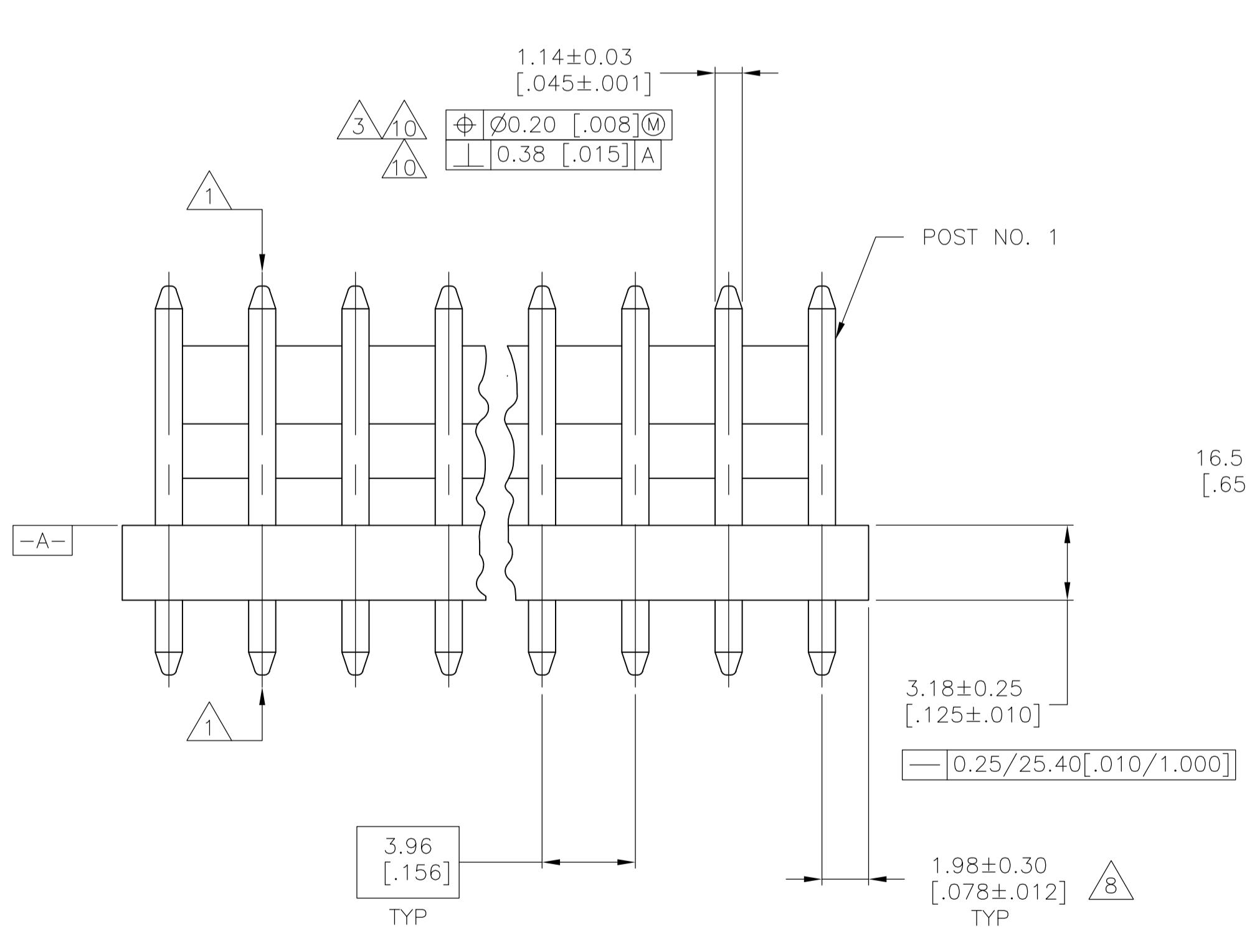

LEAD FREE	95.10 [3.744]	24	5-641209-4
	91.14 [3.588]	23	5-641209-3
	87.17 [3.432]	22	5-641209-2
	83.21 [3.276]	21	5-641209-1
	79.25 [3.120]	20	5-641209-0
	75.29 [2.964]	19	4-641209-9
	71.32 [2.808]	18	4-641209-8
	67.36 [2.652]	17	4-641209-7
	63.40 [2.496]	16	4-641209-6
	59.44 [2.340]	15	4-641209-5
	55.47 [2.184]	14	4-641209-4
	51.51 [2.028]	13	4-641209-3
	47.55 [1.872]	12	4-641209-2
	43.59 [1.716]	11	4-641209-1
	39.62 [1.560]	10	4-641209-0
	35.66 [1.404]	9	3-641209-9
	31.70 [1.248]	8	3-641209-8
	27.74 [1.092]	7	3-641209-7
	23.77 [.936]	6	3-641209-6
	19.81 [.780]	5	3-641209-5
	15.85 [.624]	4	3-641209-4
	11.89 [.468]	3	3-641209-3
	7.92 [.312]	2	3-641209-2
	DIM (L)	NO.OF POSN	ASSEMBLY

SUPERSEDED	95.10 [3.744]	24	2-641209-4
	91.14 [3.588]	23	2-641209-3
	87.17 [3.432]	22	2-641209-2
	83.21 [3.276]	21	2-641209-1
	79.25 [3.120]	20	2-641209-0
	75.29 [2.964]	19	1-641209-9
	71.32 [2.808]	18	1-641209-8
	67.36 [2.652]	17	1-641209-7
	63.40 [2.496]	16	1-641209-6
	59.44 [2.340]	15	1-641209-5
	55.47 [2.184]	14	1-641209-4
	51.51 [2.028]	13	1-641209-3
	47.55 [1.872]	12	1-641209-2
	43.59 [1.716]	11	1-641209-1
	39.62 [1.560]	10	1-641209-0
	35.66 [1.404]	9	1-641209-9
	31.70 [1.248]	8	1-641209-8
	27.74 [1.092]	7	1-641209-7
	23.77 [.936]	6	1-641209-6
	19.81 [.780]	5	1-641209-5
	15.85 [.624]	4	1-641209-4
	11.89 [.468]	3	1-641209-3
	7.92 [.312]	2	1-641209-2
	DIM (L)	NO.OF POSN	ASSEMBLY

THIS DRAWING IS A CONTROLLED DOCUMENT.

DIMENSIONS: mm [INCHES]	TOLERANCES UNLESS OTHERWISE SPECIFIED:	DIN S. HOOVER 07NOV02	TE Connectivity
0 PLC ± -	1 PLC ± -	APPRO D. ROSSI 07NOV02	MTA-156 HEADER ASSEMBLY, FRICTION LOCK, STRAIGHT, .045 ROUND POST, .000030 GOLD
2 PLC ± ± 0.13 [.005]	3 PLC ± ± -	NAME	SIZE CAGE CODE DRAWING NO. RESTRICTED TO
4 PLC ± ± -	ANGLES ± ± -	PRODUCT SPEC	A1 00779C=641209
MATERIAL	FINISH	APPLICATION SPEC	WEIGHT
		WEIGHT	SCALE 5:1 SHEET 1 OF 1 REV AL