

AG930-07E Angle Sensor Evaluation Kit

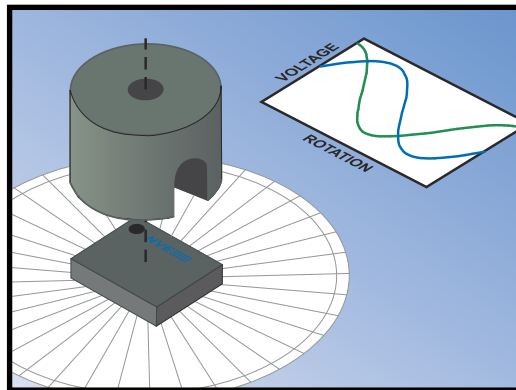

SN12425A

Kit Overview

Evaluation Kit Features

- AAT001-10E Angle Sensor
- Part # 12426 Split-Pole Alnico 5 Round Horseshoe Magnet
- Unity-Gain Buffer Amplifier
- Uses 1.5 V to 5.5 V Power Supply
- Plastic Magnet Locating Fixture

AAT001-10E Features

- Tunneling Magnetoresistance (TMR) Technology
- Very High Output Signal Without Amplification
- Wide Airgap Tolerance
- Very High Resistance for Extremely Low Power
- Sine and Cosine Outputs for Direction Detection
- Ultraminiature TDFN6 Package

AAT001-10E Applications

- Rotary Encoders
- Battery-Powered Rotary Position Sensors
- Motor Shaft Position Sensors

AAT001-10E Angle Sensor Description

The AAT001-10E angle sensor is a low power, high output magnetic sensor element able to provide rotational position measurements when a rotating magnetic field is applied to the sensor. Sine and cosine signals are available for a quadrature output.

The sensor element has a resistance of approximately 1.25 M Ω and can be operated at typical battery voltages to conserve power. Outputs are proportional to the supply voltage and peak-to-peak output voltages are much larger than other sensor technologies.

The part is packaged in NVE's 2.5 mm x 2.5 mm x 0.8 mm TDFN6 surface-mount package.

Visit www.nve.com for complete AAT001 product specifications.

Quick Start

- ⇒ Connect V_{CC1} and V_{CC2} to a 5 V power supply.
- ⇒ Connect the “SIN” and “COS” screw terminals to an oscilloscope or to meters.
- ⇒ Place the split-pole magnet in the Plexiglas pocket SLOT DOWN.
- ⇒ Rotate the magnet.

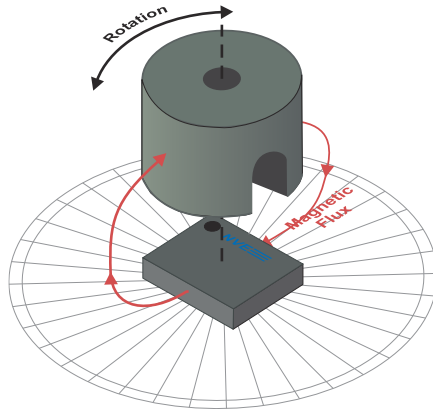

⇒ The outputs should be similar to the following graph:

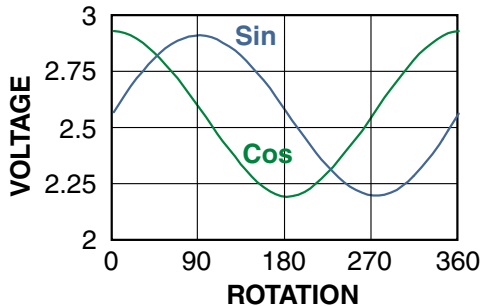

The output is insensitive to magnet spacing over a wide range. Signal is lost if the magnet is too far away; if the magnet is too close the outputs will be non-sinusoidal. A relatively large magnet-sensor airgap is possible with the magnet provided with the kit, although smaller magnets will require a smaller gap.

Evaluation Board Layout

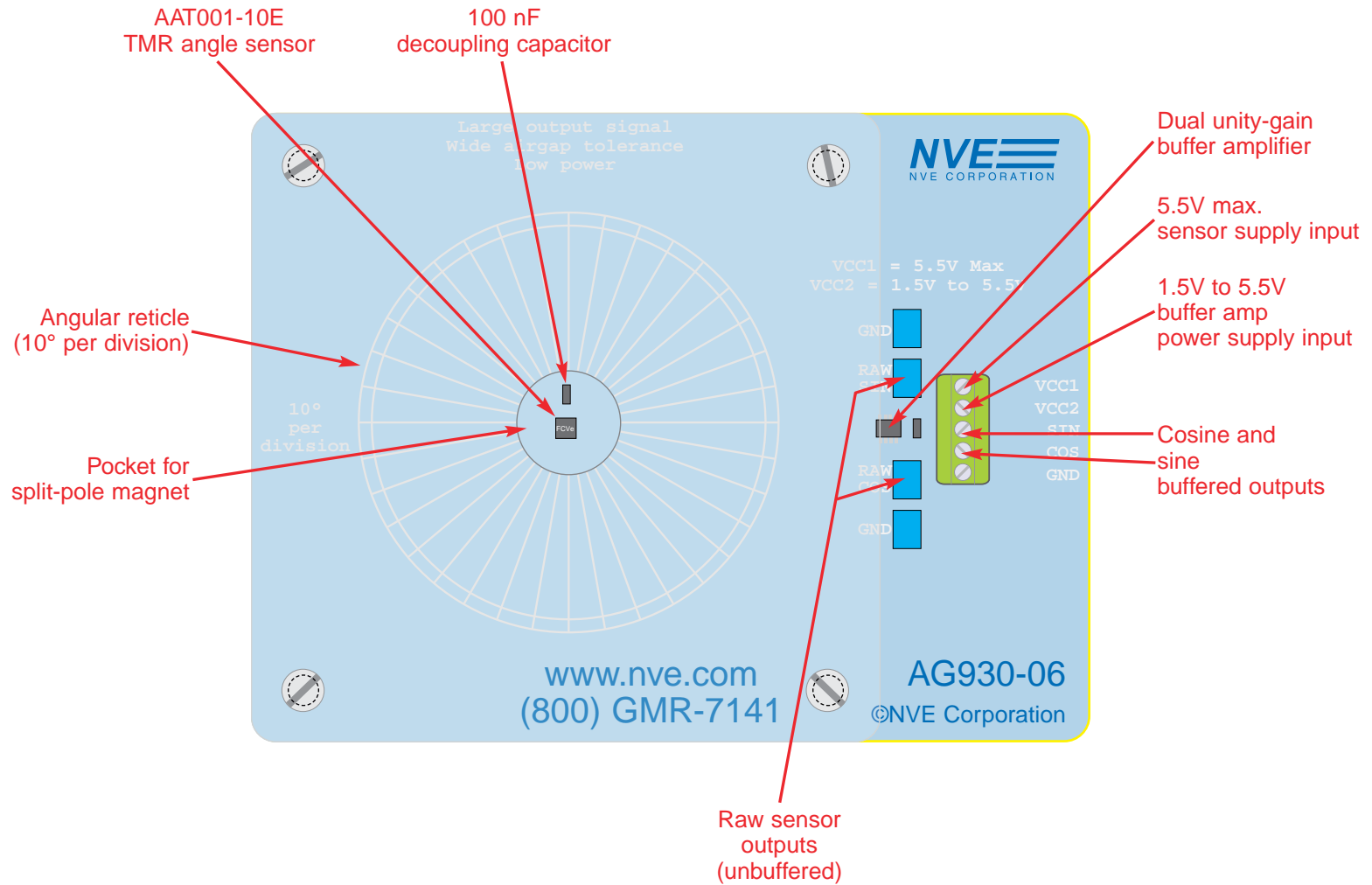

Principles of Operation

Each of the four sensor elements contains two magnetic layers: a “pinned,” or fixed direction layer; and a movable-direction, or “free” layer. Internal sensor pairs are 90° out of phase to provide quadrature outputs.

The diagram below illustrates the configuration, using arrows to represent the magnetic orientation of the layers:

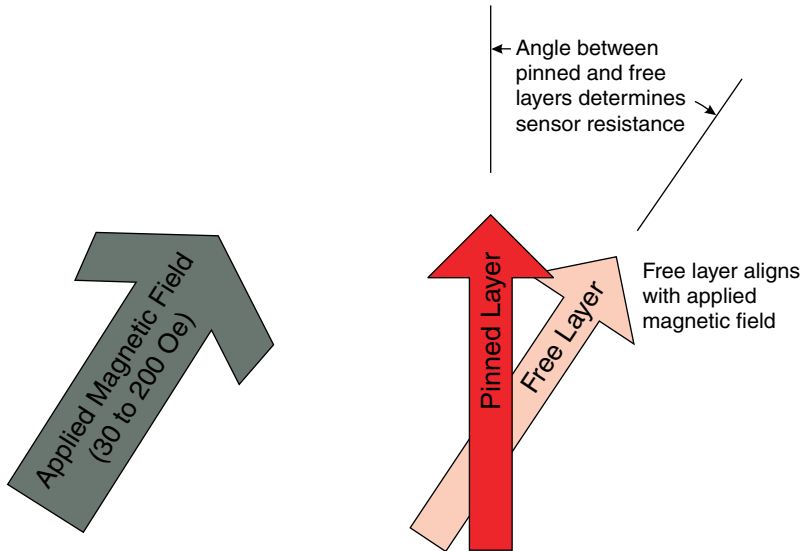

The sensor element free layers will align with the external field. As the applied field changes direction, the angle between the free layer and the pinned layer changes, changing the resistance of spintronic Tunneling Magnetoresistance (TMR) elements, which changes the device output voltages.

In the typical configuration, an external magnet provides a saturating magnetic field (30 to 200 Oe) in the plane of the sensor, as demonstrated in this kit.

Depending on the application, a bar magnet can also be used instead of a split-pole magnet.

PCB Assembly

The PCB assembly includes a unity-gain buffer with low-impedance outputs for use with ordinary multimeters, comparators, or other circuitry. These are often not suitable for direct connection to the AAT001 sensors because the resistance of the part is comparable to the internal resistance of the test instrument. The buffer amplifier outputs allow normal test instruments to be used to evaluate the part.

Raw output signals from the AAT001 are also available as test points on the board. Instruments with at least 300 M Ω internal resistance should be used for accurate raw output measurements.

In the application, connecting the sensor outputs to a high impedance input (e.g., analog microcontroller inputs) eliminates the need for a buffer amplifier.

Separate power supply connections for the sensor and op amp (V_{CC1} and V_{CC2}) allow monitoring the current requirements of the sensor only. The minimum op amp supply voltage is 1.5 V, while the AAT001 sensor has no minimum. Sensitivity increases proportionately to the sensor supply voltage, as does current consumption. V_{CC1} and V_{CC2} can be connected together if desired.

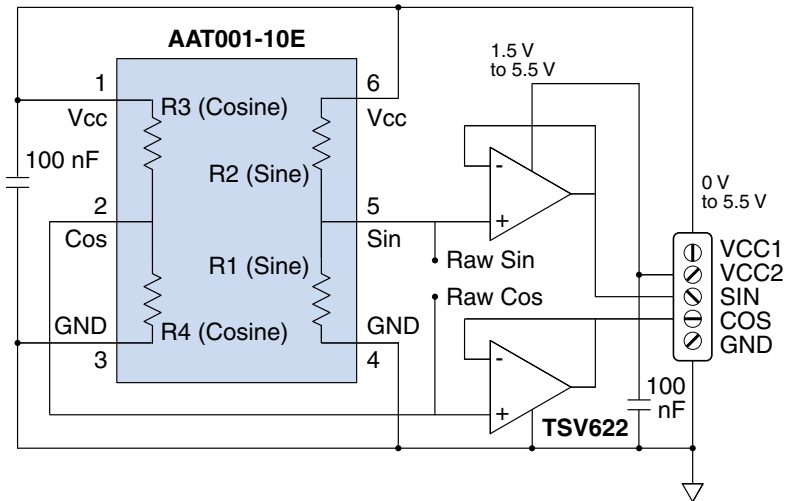

Limited Warranty and Liability

Information in this document is believed to be accurate and reliable. However, NVE does not give any representations or warranties, expressed or implied, as to the accuracy or completeness of such information and shall have no liability for the consequences of use of such information. In no event shall NVE be liable for any indirect, incidental, punitive, special or consequential damages (including, without limitation, lost profits, lost savings, business interruption, costs related to the removal or replacement of any products or rework charges) whether or not such damages are based on tort (including negligence), warranty, breach of contract or any other legal theory.

Right to Make Changes

NVE reserves the right to make changes to information published in this document including, without limitation, specifications and product descriptions at any time and without notice.

Use in Life-Critical or Safety-Critical Applications

Unless NVE and a customer explicitly agree otherwise in writing, NVE products are not designed, authorized or warranted to be suitable for use in life support, life-critical or safety-critical devices or equipment. NVE accepts no liability for inclusion or use of NVE products in such applications and such inclusion or use is at the customer's own risk. Should the customer use NVE products for such application whether authorized by NVE or not, the customer shall indemnify and hold NVE harmless against all claims and damages.

Applications

Applications described in this document are illustrative only. NVE makes no representation or warranty that such applications will be suitable for the specified use without further testing or modification. Customers are responsible for the design and operation of their applications and products using NVE products, and NVE accepts no liability for any assistance with applications or customer product design. It is customer's sole responsibility to determine whether the NVE product is suitable and fit for the customer's applications and products planned, as well as for the planned application and use of customer's third party customers. Customers should provide appropriate design and operating safeguards to minimize the risks associated with their applications and products. NVE does not accept any liability related to any default, damage, costs or problem which is based on any weakness or default in the customer's applications or products, or the application or use by customer's third party customers. The customer is responsible for all necessary testing for the customer's applications and products using NVE products in order to avoid a default of the applications and the products or of the application or use by customer's third party customers. NVE accepts no liability in this respect.

An ISO 9001 Certified Company

NVE Corporation
11409 Valley View Road
Eden Prairie, MN 55344-3617

©NVE Corporation

All rights are reserved. Reproduction in whole or in part is prohibited without the prior written consent of the copyright owner.

Manual No.: SN12425A