

PERFORMANCE

(measured using Carbon Monoxide)

Range 0 - 100 ppm
 Sensitivity 440 - 1080nA/ppm ETO
 Zero in air at 20 °C -200 to +2500 nA
 Resolution 1 ppm ETO
 Linearity linear across range
 Response time, t90 <45 s
 Long-term output drift <2% signal/month
 Warranty 2 years

OPERATING CONDITIONS

Temperature range -20 to +50 °C
 Operating humidity 15 - 90% RH (non-condensing)
 Pressure range 90 - 110 kPa (nominal)
 Operating circuit see Electrochemical Toxic Sensor Application Note
 Applied potential +300 mV
 Storage life 6 months in original packaging (0 - 25 °C)

PHYSICAL CHARACTERISTICS

Label colour silver
 Weight 5 g approx.
 Dimensions see outline

This device is designed to be RoHS compliant.

CROSS-SENSITIVITY DATA

GAS	Concentration ppm	Sensor Response (As ppm CO)
Carbon Monoxide	100	100
Ethylene Oxide	100	1056
Ethanol	100	325
Methanol	100	800
Propan-1-Ol	100	207
Butan-1-ene	100	279
1,3 Butadiene	100	915
Ethene	100	342
Propene	100	310
Vinyl Chloride	100	113
Vinyl Acetate	100	511
Formic Acid	100	167
Formaldehyde	100	715
Acrylonitrile	100	113

Note: This table is for reference only. Calibration should be carried out with the actual gas at a known concentration.

OUTLINE

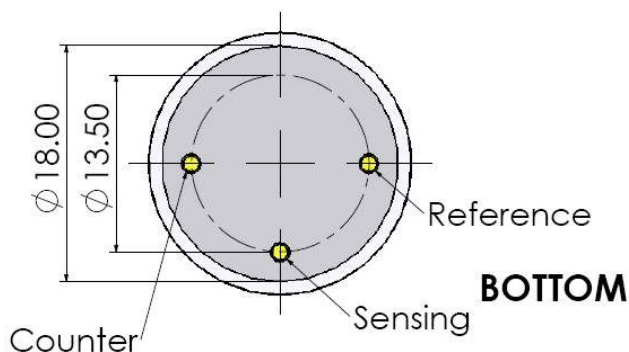
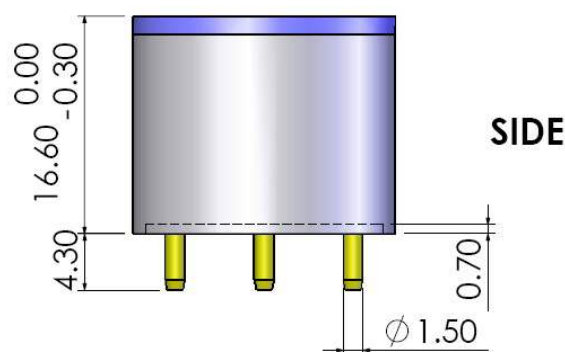
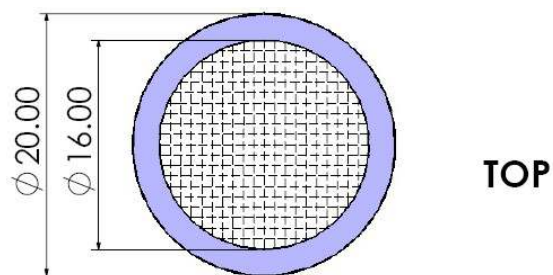

All dimensions in mm.
 All tolerances ±0.15mm unless otherwise stated.

Important Note

Do not solder to the connector pins as this may damage the sensor and thereby invalidate the warranty.

Details on recommended connector pins can be found in the Frequently Asked Questions within the Gas Sensor section of the SGX website.

TEMPERATURE DEPENDENCE

EC4-100-ETO Graph of Zero vs Temperature

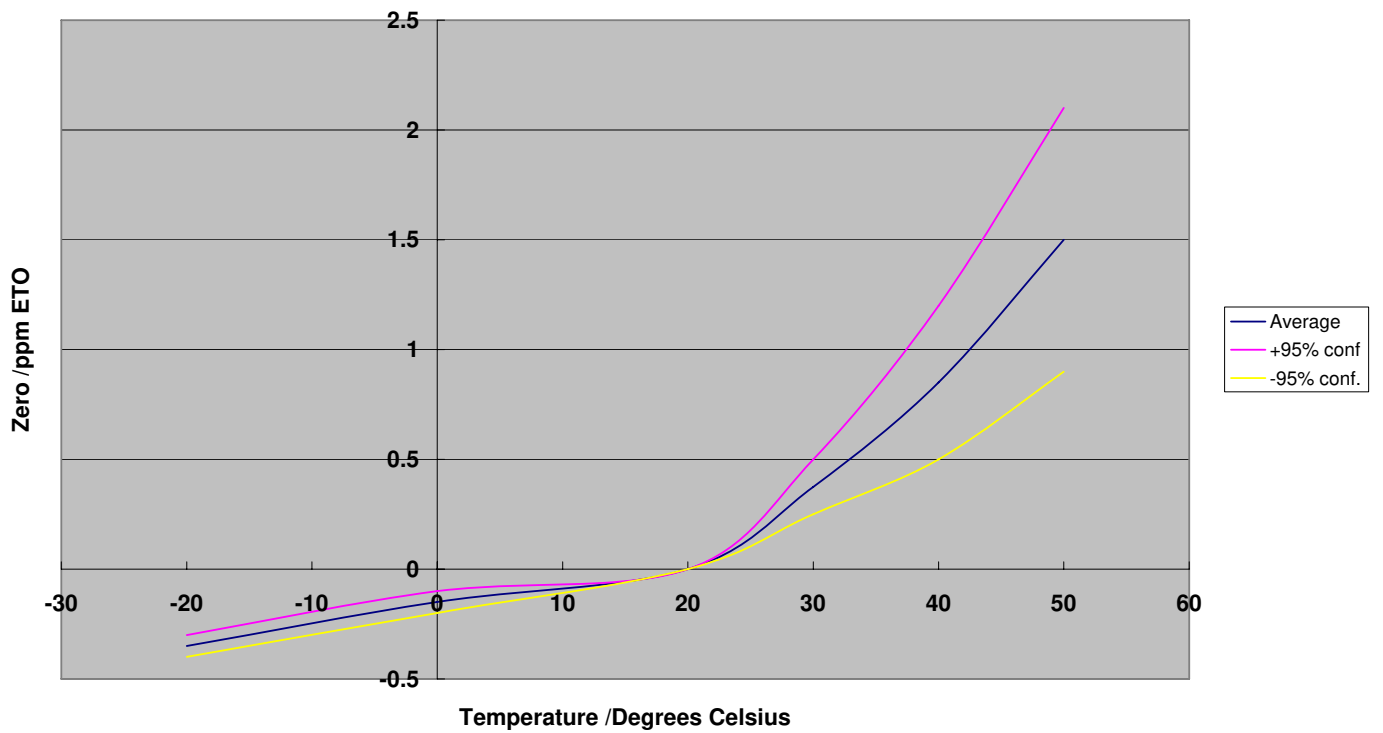

EC4-100-ETO Graph of Sensitivity vs Temperature

