

## EIA/ITU 24V PABX SLIC with 25mA Loop Feed

The HC-5524 telephone Subscriber Line Interface Circuit integrates most of the BORSCHT functions on a monolithic IC. The device is manufactured in a Dielectric Isolation (DI) process and is designed for use as a 24V interface between the traditional telephone subscriber pair (Tip and Ring) and the low voltage filtering and coding/decoding functions of the line card. Together with a secondary protection diode bridge, the device will withstand 500V induced surges, in plastic packages. The SLIC also maintains specified transmission performance in the presence of externally induced longitudinal currents. The BORSCHT functions that the SLIC provides are:

- Battery Feed with Subscriber Loop Current Limiting
- Overvoltage Protection
- Ring Relay Driver
- Supervisory Signaling Functions
- Hybrid Functions (with External Op-Amp)
- Test (or Battery Reversal) Relay Driver

In addition, the SLIC provides selective denial of power to subscriber loops, a programmable subscriber loop current limit from 20mA to 60mA, a thermal shutdown with an alarm output and line fault protection. Switch hook detection, ring trip detection and ground key detection functions are also incorporated in the SLIC device.

The HC-5524 SLIC is ideally suited for line card designs in PBX and DLC systems, replacing traditional transformer solutions.

### Ordering Information

PART NUMBER	TEMP. RANGE (°C)	PACKAGE	PKG. NO.
HC3-5524-5	0 to 75	28 Ld PDIP	E28.6
HC3-5524-9	-40 to 85	28 Ld PDIP	E28.6
HC4P5524-5	0 to 75	44 Ld PLCC	N44.65
HC4P5524-9	-40 to 85	44 Ld PLCC	N44.65
HC9P5524-5	0 to 75	28 Ld SOIC	M28.3
HC9P5524-9	-40 to 85	28 Ld SOIC	M28.3

### Features

- DI Monolithic High Voltage Process
- Compatible with Worldwide PBX and DLC Performance Requirements
- Controlled Supply of Battery Feed Current with Programmable Current Limit
- Operates with 5V Positive Supply ( $V_{B+}$ )
- Internal Ring Relay Driver and a Utility Relay Driver
- High Impedance Mode for Subscriber Loop
- High Temperature Alarm Output
- Low Power Consumption During Standby Functions
- Switch Hook, Ground Key, and Ring Trip Detection
- Selective Power Denial to Subscriber
- Voice Path Active During Power Denial
- On-Chip Op Amp for 2-Wire Impedance Matching

### Applications

- Solid State Line Interface Circuit for PBX or Digital Loop Carrier Systems
- Hotel/Motel Switching Systems
- Direct Inward Dialing (DID) Trunks
- Voice Messaging PBXs
- 2-Wire/4-Wire, 4-Wire/2-Wire Hybrid
- Related Literature
  - AN9607, Impedance Matching Design Equations
  - AN9628, AC Voltage Gain
  - AN9608, Implementing Pulse Metering
  - AN549, The HC-5502S/4X Telephone Subscriber Line Interface Circuits (SLIC)

# HC-5524

## Absolute Maximum Ratings (Note 1)

Maximum Supply Voltages	
(V <sub>B+</sub> )	-0.5V to 7V
(V <sub>B+</sub> ) - (V <sub>B-</sub> )	40V
Relay Drive Voltage	-0.5V to 15V

## Operating Conditions

Operating Temperature Range	
HC-5524-5	0°C to T <sub>A</sub> to 75°C
HC-5524-9	-40°C to T <sub>A</sub> to 85°C
Relay Driver Voltage	5V to 12V
Positive Power Supply (V <sub>B+</sub> )	5V ±5%
Negative Power Supply (V <sub>B-</sub> )	-20V to -28V

## Thermal Information

Thermal Resistance (Typical, Note 2)	θ <sub>JA</sub> (°C/W)
PDIP Package	55
PLCC Package	47
SOIC Package	75
Maximum Junction Temperature (Plastic Package)	150°C
Maximum Storage Temperature Range	-65°C to T <sub>A</sub> to 150°C
Maximum Lead Temperature (Soldering 10s)	300°C (PLCC and SOIC - Lead Tips Only)

## Die Characteristics

Transistor Count	224
Diode Count	28
Die Dimensions	.174 mils x 120 mils
Substrate Potential	Connected
Process	Bipolar-DI

*CAUTION: Stresses above those listed in "Absolute Maximum Ratings" may cause permanent damage to the device. This is a stress only rating and operation of the device at these or any other conditions above those indicated in the operational sections of this specification is not implied.*

### NOTES:

1. Absolute maximum ratings are limiting values, applied individually, beyond which the serviceability of the circuit may be impaired. Functional operability under any of these conditions is not necessarily implied.
2. θ<sub>JA</sub> is measured with the component mounted on an evaluation PC board in free air.

**Electrical Specifications** Typical Parameters are at T<sub>A</sub> = 25°C, V<sub>B+</sub> = 5V, V<sub>B-</sub> = -24V, AG = DG = BG = 0V. Min-Max Parameters are Over Operating Positive and Negative Battery Voltages and Over the Operating Temperature Range. All Parameters are Specified at 600W 2-Wire Terminating Impedance, Unless Otherwise Specified

PARAMETER	TEST CONDITIONS	MIN	TYP	MAX	UNITS
<b>AC TRANSMISSION PARAMETERS</b>					
RX Input Impedance	300Hz to 3.4kHz, (Note 3)	-	100	-	kΩ
TX Output Impedance		-	-	20	Ω
4-Wire Input Overload Level	300Hz to 3.4kHz, 600Ω Reference	+1.0	-	-	V <sub>PEAK</sub>
2-Wire Return Loss	Matched for 600Ω, (Note 3)				
SRL LO		26	35	-	dB
ERL		30	40	-	dB
SRL HI		30	40	-	dB
2-Wire Longitudinal to Metallic Balance Off Hook	Per ANSI/IEEE STD 455-1976, 300Hz to 3400Hz, (Note 3)	58	63	-	dB
4-Wire Longitudinal Balance Off Hook	Per ANSI/IEEE STD 455-1976, 300Hz to 3400Hz, (Note 3)	50	55	-	dB
Low Frequency Longitudinal Balance	R.E.A. Test Circuit	-	-80	-67	dBmp
	I <sub>LINE</sub> = 40mA, T <sub>A</sub> = 25°C (Note 3)	-	10	23	dBrnC
Longitudinal Current Capability	I <sub>LINE</sub> = 40mA, T <sub>A</sub> = 25°C (Note 3)	-	-	40	mA <sub>RMS</sub>
Insertion Loss					
2-Wire/4-Wire	-1.58dBm at 1kHz, Referenced 600Ω	-	±0.05	±0.2	dB
4-Wire/2-Wire	0dBm at 1kHz, Referenced 600Ω	-	±0.05	±0.2	dB
4-Wire/4-Wire	-1.58dBm at 1kHz, Referenced 600Ω	-	-	±0.2	dB
Frequency Response	300Hz to 3400Hz, Referenced to Absolute Level at 1kHz, 0dBm Referenced 600Ω (Note 3)	-	±0.02	±0.06	dB

## HC-5524

**Electrical Specifications** Typical Parameters are at  $T_A = 25^\circ\text{C}$ ,  $V_{B+} = 5\text{V}$ ,  $V_{B-} = -24\text{V}$ ,  $A_G = D_G = B_G = 0\text{V}$ . Min-Max Parameters are Over Operating Positive and Negative Battery Voltages and Over the Operating Temperature Range. All Parameters are Specified at 600W 2-Wire Terminating Impedance, Unless Otherwise Specified **(Continued)**

PARAMETER	TEST CONDITIONS	MIN	TYP	MAX	UNITS	
Level Linearity 2-Wire to 4-Wire and 4-Wire to 2-Wire	Referenced to -10dBm, (Note 3) +3 to -40dBm	-	-	$\pm 0.08$	dB	
	-40 to -50dBm	-	-	$\pm 0.12$	dB	
	-50 to -55dBm	-	-	$\pm 0.3$	dB	
Absolute Delay 2-Wire/4-Wire	(Note 2) 300Hz to 3400Hz	-	-	1	$\mu\text{s}$	
	4-Wire/2-Wire	-	-	1	$\mu\text{s}$	
	4-Wire/4-Wire	-	0.95	1.5	$\mu\text{s}$	
Total Harmonic Distortion 2-Wire/4-Wire, 4-Wire/2-Wire, 4-Wire/4-Wire	Reference Level 0dBm at 600 $\Omega$ , 300Hz to 3400Hz (Note 3)	-	-	-50	dB	
Idle Channel Noise 2-Wire and 4-Wire	C-Message, (Note 3)	-	-	5	dB <sub>BrnC</sub>	
	Psophometric	-	-	-85	dB <sub>mp</sub>	
	3kHz Flat	-	-	16	dB <sub>Brn</sub>	
Open Loop Voltage ( $V_{TIP} - V_{RING}$ )	$V_{B+} = 5\text{V}$ , $V_{B-} = -24\text{V}$	-	15.8	-	V	
Power Supply Rejection Ratio	30Hz to 200Hz, $R_L = 600\Omega$ , (Note 3)	$V_{B+}$ to 2-Wire	20	40	-	dB
		$V_{B+}$ to 4-Wire	20	40	-	dB
		$V_{B-}$ to 2-Wire	20	40	-	dB
		$V_{B-}$ to 4-Wire	20	50	-	dB
	200Hz to 16kHz, $R_L = 600\Omega$	$V_{B+}$ to 2-Wire	30	40	-	dB
		$V_{B+}$ to 4-Wire	20	28	-	dB
		$V_{B-}$ to 2-Wire	20	50	-	dB
		$V_{B-}$ to 4-Wire	20	50	-	dB
Ring Sync Pulse Width		50	-	500	$\mu\text{s}$	
<b>DC PARAMETERS</b>						
Loop Current Programming Limit Range		20	-	60	mA	
		Accuracy	10	-	-	%
Loop Current During Power Denial	$R_L = 200\Omega$	-	$\pm 4$	$\pm 7$	mA	
Fault Currents		TIP to Ground	-	30	-	mA
		RING to Ground	-	120	-	mA
		TIP and RING to Ground	-	150	-	mA
Switch Hook Detection Threshold		-	12	15	mA	
Ground Key Detection Threshold		-	10	-	mA	
Thermal $\overline{\text{ALM}}$ Output	Safe Operating Die Temperature Exceeded	140	-	160	$^\circ\text{C}$	
Ring Trip Detection Threshold	$V_{RING} = 105V_{RMS}$ , $f_{RING} = 20\text{Hz}$	-	10	-	mA	
Ring Trip Detection Period		-	100	150	ms	
Dial Pulse Distortion		-	0.1	0.5	ms	

## HC-5524

**Electrical Specifications** Typical Parameters are at  $T_A = 25^\circ\text{C}$ ,  $V_{B+} = 5\text{V}$ ,  $V_{B-} = -24\text{V}$ ,  $AG = DG = BG = 0\text{V}$ . Min-Max Parameters are Over Operating Positive and Negative Battery Voltages and Over the Operating Temperature Range. All Parameters are Specified at 600W 2-Wire Terminating Impedance, Unless Otherwise Specified **(Continued)**

PARAMETER	TEST CONDITIONS	MIN	TYP	MAX	UNITS
Relay Driver Outputs					
On Voltage $V_{OL}$	$I_{OL}(\overline{PR}) = 60\text{mA}$ , $I_{OL}(\overline{RD}) = 30\text{mA}$	-	0.2	0.5	V
Off Leakage Current	$V_{OH} = 13.2\text{V}$	-	$\pm 10$	$\pm 100$	$\mu\text{A}$
TTL/CMOS Logic Inputs (F0, F1, RS, $\overline{\text{TST}}$ , PRI)					
Logic '0' $V_{IL}$		-	-	0.8	V
Logic '1' $V_{IH}$		2.0	-	5.5	V
Input Current (F0, F1, RS, $\overline{\text{TST}}$ , PRI)	$0\text{V} \leq V_{IN} \leq 5\text{V}$	-	-	$\pm 100$	$\mu\text{A}$
Logic Outputs					
Logic '0' $V_{OL}$	$I_{LOAD} = 800\mu\text{A}$	-	0.1	0.5	V
Logic '1' $V_{OH}$	$I_{LOAD} = 40\mu\text{A}$	2.7	-	-	V
Power Dissipation On Hook	Relay Drivers Off	-	60	-	mW
$I_{B+}$	$V_{B+} = 5.25\text{V}$ , $V_{B-} = -28\text{V}$ , $R_{LOOP} = \infty$	-	-	4	mA
$I_{B-}$	$V_{B+} = 5.25\text{V}$ , $V_{B-} = -28\text{V}$ , $R_{LOOP} = \infty$	-4	-	-	mA
$I_{B+}$	$V_{B+} = 5\text{V}$ , $V_{B-} = -24\text{V}$ , $R_{LOOP} = 600\Omega$	-	3	6	mA
$I_{B-}$	$V_{B+} = 5\text{V}$ , $V_{B-} = -24\text{V}$ , $R_{LOOP} = 600\Omega$	-28	-24	-	mA
<b>UNCOMMITTED OP AMP PARAMETERS</b>					
Input Offset Voltage		-	$\pm 5$	-	mV
Input Offset Current		-	$\pm 10$	-	nA
Differential Input Resistance	(Note 3)	-	1	-	$\text{M}\Omega$
Output Voltage Swing	$R_L = 10\text{k}\Omega$	-	$\pm 3$	-	$V_{P-P}$
Small Signal GBW	(Note 3)	-	1	-	MHz

NOTE:

- These parameters are controlled by design or process parameters and are not directly tested. These parameters are characterized upon initial design release, upon design changes which would affect these characteristics, and at intervals to assure product quality and specification compliance.

## Pin Descriptions

DIP/ SOIC	PLCC	SYMBOL	DESCRIPTION
1	2	AG (Note 4)	Analog Ground - To be connected to zero potential. Serves as a reference for the transmit output and receive input terminals.
2	3	$V_{B+}$	Positive Voltage Source - Most Positive Supply.
3	4	$C_1$	Capacitor # $C_1$ - An external capacitor to be connected between this terminal and analog ground. Required for proper operation of the loop current limiting function.
4	8	F1	Function Address #1 - A TTL and CMOS compatible input used with F0 function address line to externally select logic functions. The three selectable functions are mutually exclusive. See Truth Table on front page. F1 should be toggled high after power is applied.
5	9	F0	Function Address #0 - A TTL and CMOS compatible input used with F1 function address line to externally select logic functions. The three selectable functions are mutually exclusive. See Truth Table on front page.
6	10	RS	Ring Synchronization Input - A TTL - compatible clock input. The clock is arranged such that a positive pulse (50 $\mu\text{s}$ - 500 $\mu\text{s}$ ) occurs on the zero crossing of the ring voltage source, as it appears at the RFS terminal. For Tip side injected systems, the RS pulse should occur on the negative going zero crossing and for Ring injected systems, on the positive going zero crossing. This ensures that the ring delay activates and deactivates when the instantaneous ring voltage is near zero. If synchronization is not required, the pin should be tied to +5V.

**Pin Descriptions** (Continued)

DIP/ SOIC	PLCC	SYMBOL	DESCRIPTION
7	11	$\overline{\text{SHD}}$	Switch Hook Detection - An active low LS TTL compatible logic output. A line supervisory output.
8	12	$\overline{\text{GKD}}$	Ground Key Detection - An active low LS TTL compatible logic output. A line supervisory output.
9	13	$\overline{\text{TST}}$	A TTL logic input. A low on this pin will set a latch and keep the SLIC in a power down mode until the proper F1, F0 state is set and will keep $\overline{\text{ALM}}$ low. See Truth Table on front page.
10	17	$\overline{\text{ALM}}$	A LS TTL compatible active low output which responds to the thermal detector circuit when a safe operating die temperature has been exceeded. When $\overline{\text{TST}}$ is forced low by an external control signal, $\overline{\text{ALM}}$ is latched low until the proper F1, F0 state and $\overline{\text{TST}}$ input is brought high. The $\overline{\text{ALM}}$ can be tied directly to the $\overline{\text{TST}}$ pin to power down the part when a thermal fault is detected and then reset with F0, F1. See Truth Table on front page. It is possible to ignore transient thermal overload conditions in the SLIC by delaying the response to the $\overline{\text{TST}}$ pin from the $\overline{\text{ALM}}$ . Care must be exercised in attempting this as continued thermal overstress may reduce component life.
11	18	$I_{\text{LIMIT}}$	Loop Current Limit - Voltage on this pin sets the short loop current limiting conditions using a resistive voltage divider.
12	19	OUT1	The analog output of the spare operational amplifier.
13	20	-IN1	The inverting analog input of the spare operational amplifier.
14	22	TIP	An analog input connected to the TIP (more positive) side of the subscriber loop through a feed resistor and ring relay contact. Functions with the RING terminal to receive voice signals from the telephone and for loop monitoring purposes.
15	24	RING	An analog input connected to the RING (more negative) side of the subscriber loop through a feed resistor. Functions with the TIP terminal to receive voice signals from the telephone and for loop monitoring purposes.
16	25	RFS	Ring Feed Sense - Senses RING side of the loop for Ground Key Detection. During Ring injected ringing the ring signal at this node is isolated from RF via the ring relay. For Tip injected ringing, the RF and RFS pins must be shorted.
17	27	$V_{\text{RX}}$	Receive Input, 4-Wire Side - A high impedance analog input. AC signals appearing at this input drive the Tip Feed and Ring Feed amplifiers differentially.
18	31	$C_2$	Capacitor #2 - An external capacitor to be connected between this terminal and ground. It prevents false ring trip detection from occurring when longitudinal currents are induced onto the subscriber loop from power lines and other noise sources. This capacitor should be nonpolarized.
19	32	$V_{\text{TX}}$	Transmit Output, 4-Wire Side - A low impedance analog output which represents the differential voltage across TIP and RING. Transhybrid balancing must be performed beyond this output to completely implement two to four wire conversion. This output is referenced to analog ground. Since the DC level of this output varies with loop current, capacitive coupling to the next stage is necessary.
20	33	PRI	A TTL compatible input used to control $\overline{\text{PR}}$ . PRI active High = $\overline{\text{PR}}$ active low.
21	34	$\overline{\text{PR}}$	An active low open collector output. Can be used to drive a Polarity Reversal Relay.
22	35	DG (Note 4)	Digital Ground - To be connected to zero potential. Serves as a reference for all digital inputs and outputs on the SLIC.
23	36	$\overline{\text{RD}}$	Ring Relay Driver - An active low open collector output. Used to drive a relay that switches ringing signals onto the 2-Wire line.
24	37	$V_{\text{FB}}$ (Note 5)	Feedback input to the tip feed amplifier; may be used in conjunction with transmit output signal and the spare op-amp to accommodate 2-Wire line impedance matching. (This is not used in the typical applications circuit).
25	38	TF <sub>2</sub>	Tip Feed - A low impedance analog output connected to the TIP terminal through a feed resistor. Functions with the RF terminal to provide loop current, and to feed voice signals to the telephone set and to sink longitudinal currents. Must be tied to TF <sub>1</sub> .
NA	39	TF <sub>1</sub>	Tie directly to TF <sub>2</sub> in the PLCC application.
26	41	RF <sub>1</sub>	Ring Feed - A low impedance analog output connected to the RING terminal through a feed resistor. Functions with the TF terminal to provide loop current, feed voice signals to the telephone set, and to sink longitudinal currents. Tie directly to RF <sub>2</sub> .
NA	42	RF <sub>2</sub>	Tie directly to RF <sub>1</sub> in the PLCC application.
27	43	$V_{\text{B-}}$	The battery voltage source. The most negative supply.

# HC-5524

## Pin Descriptions (Continued)

DIP/ SOIC	PLCC	SYMBOL	DESCRIPTION
28	44	BG (Note 4)	Battery Ground - To be connected to zero potential. All loop current and some quiescent current flows into this ground terminal.
	1, 5, 6, 7, 14, 15, 16, 21, 23, 26, 28, 29, 30, 40	NC	No internal connection.

### NOTES:

- All grounds (AG, BG, and DG) must be applied before  $V_{B+}$  or  $V_{B-}$ . Failure to do so may result in premature failure of the part. If a user wishes to run separate grounds off a line card, the AG must be applied first.
- Although not used in the typical applications circuit,  $V_{FB}$  may be used in matching complex 2-Wire impedances.

## Pinouts

**HC-5524 (PDIP, SOIC)**  
TOP VIEW

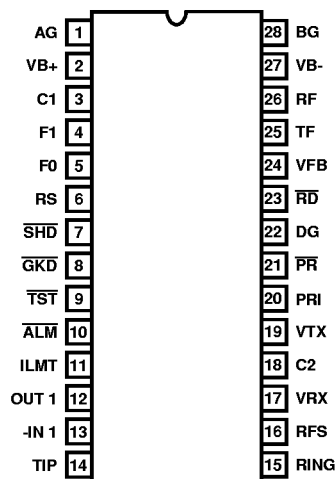

**TRUTH TABLE**

F1	F0	Action
0	0	Normal Loop Feed
0	1	$\overline{RD}$ Active
1	0	Power Down Latch RESET
1	0	Power on RESET
1	1	Loop Power Denial Active

**HC-5524 (PLCC)**  
TOP VIEW

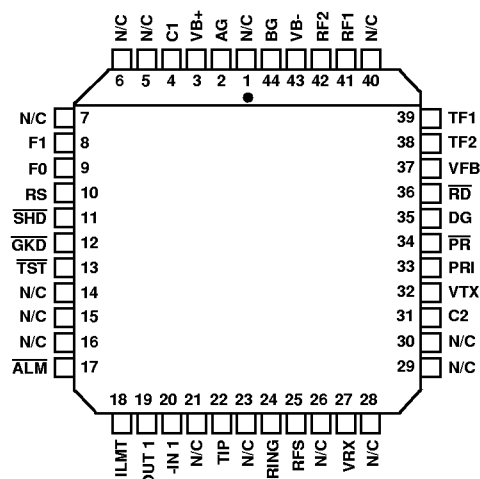

Functional Diagram

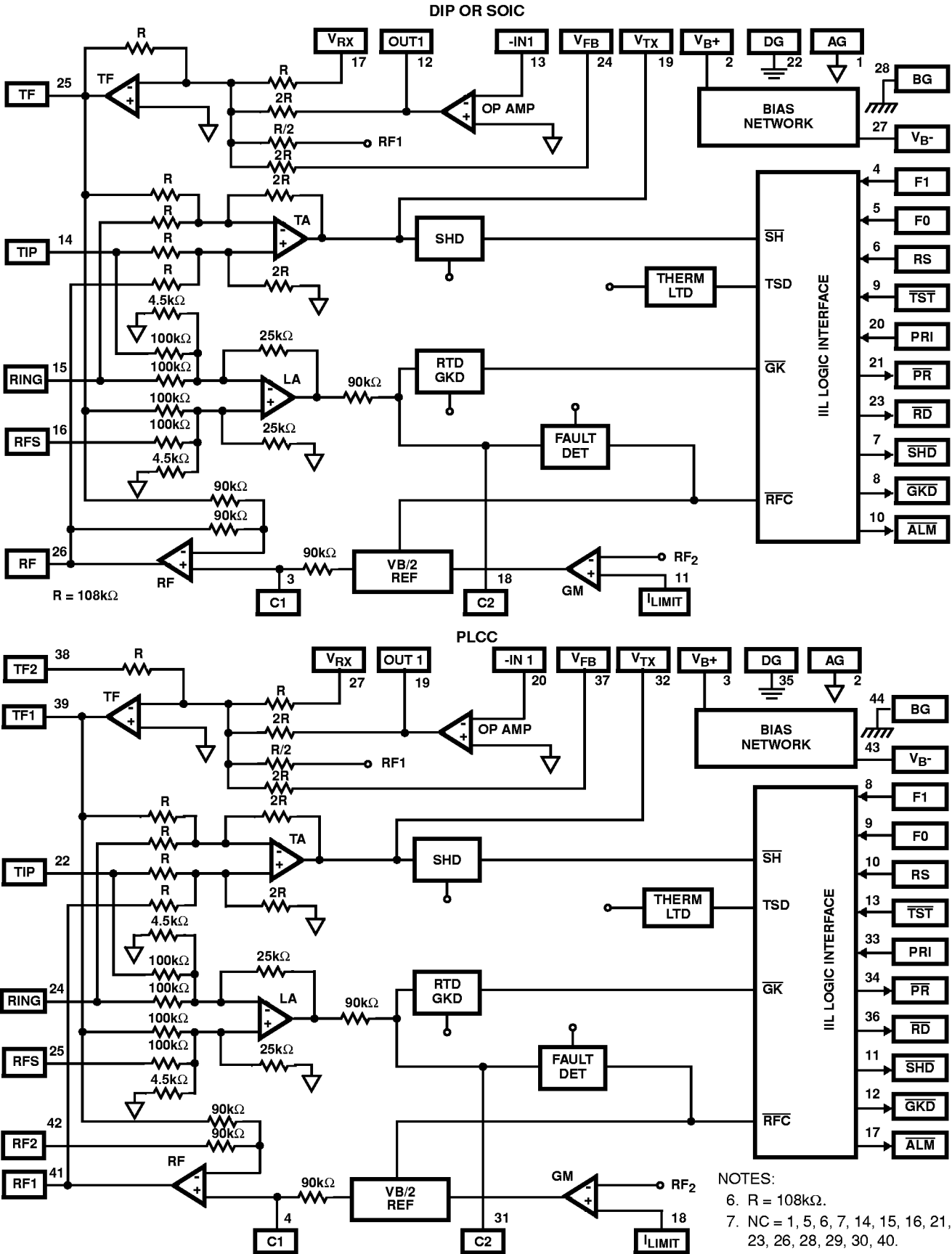

Logic Diagram

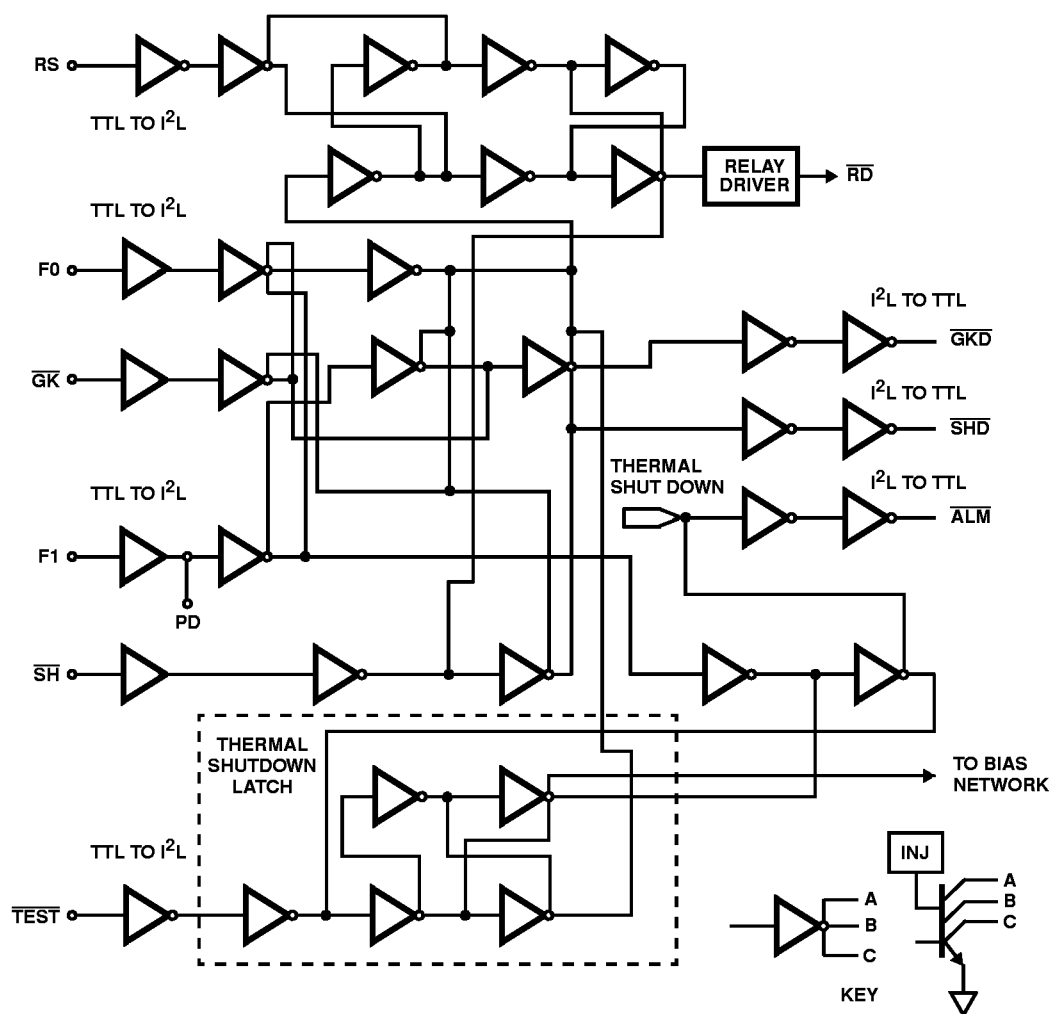

Overvoltage Protection and Longitudinal Current Protection

The SLIC device, in conjunction with an external protection bridge, will withstand high voltage lightning surges and power line crosses.

High voltage surge conditions are as specified in Table 1.

The SLIC will withstand longitudinal currents up to a maximum of 40mARMS, 20mARMS per leg, without any performance degradation.

TABLE 1.

PARAMETER	TEST CONDITION	PERFORMANCE (MAX)	UNITS
Longitudinal Surge	10µs Rise/ 1000µs Fall	±1000 (Plastic)	VPEAK
Metallic Surge	10µs Rise/ 1000µs Fall	±1000 (Plastic)	VPEAK
T/GND R/GND	10µs Rise/ 1000µs Fall	±1000 (Plastic)	VPEAK
50/60Hz Current T/GND R/GND	11 Cycles Limited to 10ARMS	700 (Plastic)	VRMS



Typical Applications

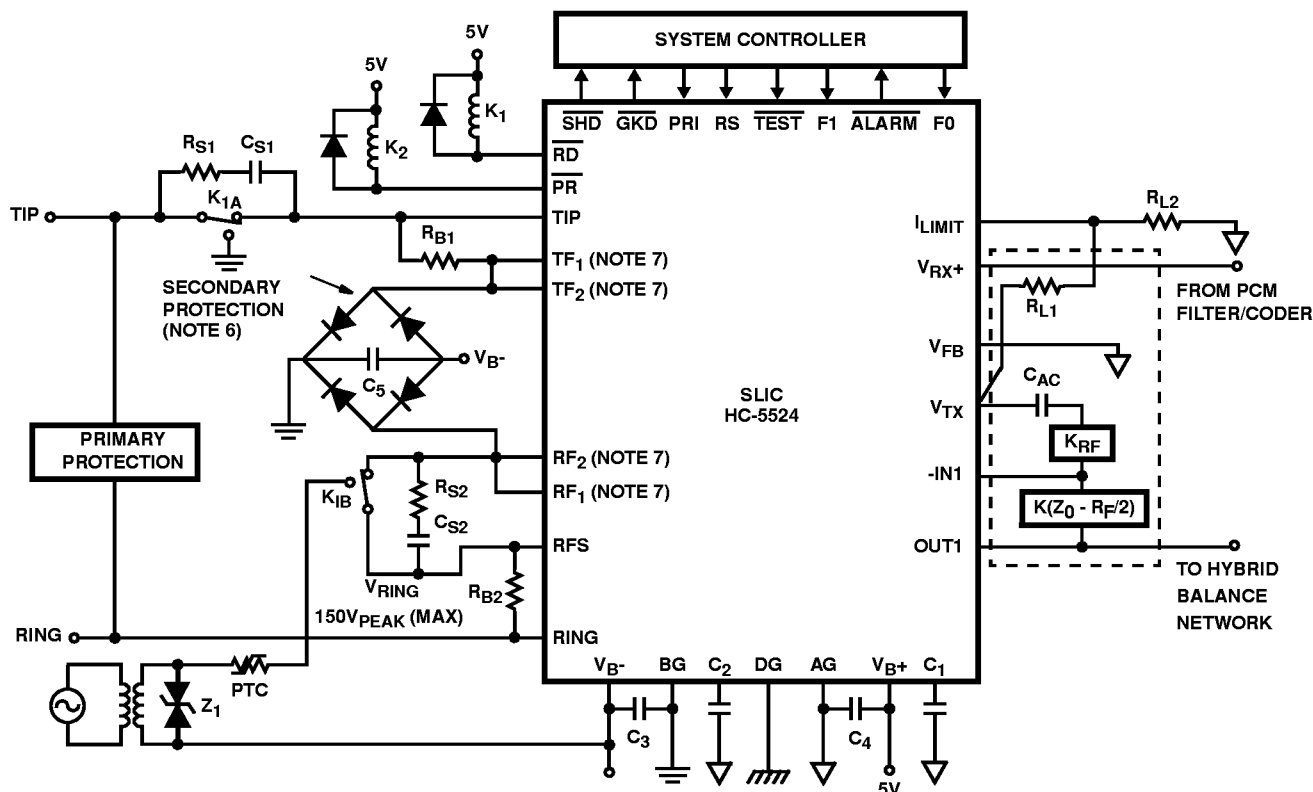

FIGURE 1. TYPICAL LINE CIRCUIT APPLICATION WITH THE MONOLITHIC SLIC

Typical Component Values

$C_1 = 0.5\mu\text{F}$ , 20V.

$C_2 = 1.0\mu\text{F} \pm 10\%$ , 20V (for other values of  $C_2$ , refer to AN9667).

$C_3 = 0.01\mu\text{F}$ , 50V  $\pm 20\%$ .

$C_4 = 0.01\mu\text{F}$ , 50V  $\pm 20\%$ .

$C_5 = 0.01\mu\text{F}$ , 50V  $\pm 20\%$ .

$C_{AC} = 0.5\mu\text{F}$ , 20V.

$K(Z_0 - R_F/2) = 50\text{k}\Omega$ , ( $Z_0 = 600\Omega$ ,  $K = \text{Scaling Factor} = 100$ ).

$R_{L1}$ ,  $R_{L2}$ ; Current Limit Setting Resistors.

$R_{L1} + R_{L2} > 90\text{k}\Omega$ .

$I_{LIMIT} = (.6) (R_{L1} + R_{L2}) / (200 \times R_{L2})$ ,  $R_{L1}$  typically  $100\text{k}\Omega$ .

$KR_F = 20\text{k}\Omega$ ,  $R_F = 2(R_{B1} + R_{B2})$ ,  $K = \text{Scaling Factor} = 100$ .

$R_{B1} = R_{B2} = 50\Omega$  (1% absolute, matching requirements covered in a Tech Brief).

$R_{S1} = R_{S2} = 1\text{k}\Omega$  typically.

$C_{S1} = C_{S2} = 0.1\mu\text{F}$ , 200V typically, depending on  $V_{Ring}$  and line length.

$Z_1 = 150\text{V}$  to  $200\text{V}$  transient protector. PTC used as ring generator ballast.

NOTES:

8. All grounds (AG, BG, and DG) must be applied before  $V_{B+}$  or  $V_{B-}$ . Failure to do so may result in premature failure of the part. If a user wishes to run separate grounds off a line card, the AG must be applied first.
9. Application shows Ring Injected Ringing, Balanced or Tip injected configuration may be used.
10. Secondary protection diode bridge recommended is 3A, 200V type.
11.  $TF_1$ ,  $TF_2$  and  $RF_1$ ,  $RF_2$  are on PLCC only and should be connected together as shown.

Dual-In-Line Plastic Packages (PDIP)

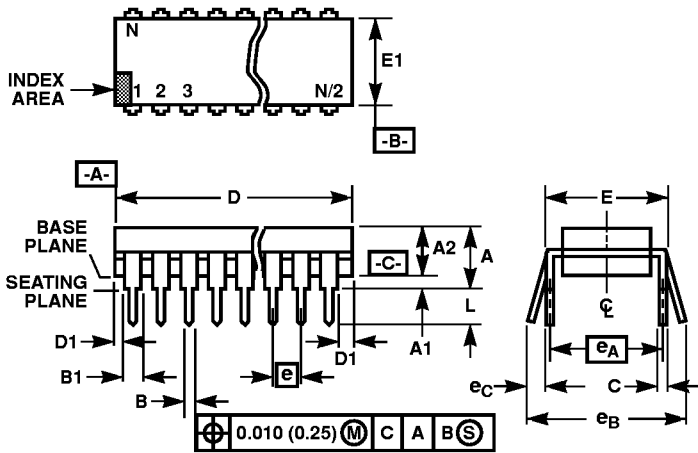

**E28.6 (JEDEC MS-001-BF ISSUE D)**  
**28 LEAD NARROW BODY DUAL-IN-LINE PLASTIC PACKAGE**

SYMBOL	INCHES		MILLIMETERS		NOTES
	MIN	MAX	MIN	MAX	
A	-	0.250	-	6.35	4
A1	0.015	-	0.39	-	4
A2	0.125	0.195	3.18	4.95	-
B	0.014	0.022	0.356	0.558	-
B1	0.030	0.070	0.77	1.77	8
C	0.008	0.015	0.204	0.381	-
D	1.380	1.565	35.1	39.7	5
D1	0.005	-	0.13	-	5
E	0.600	0.625	15.24	15.87	6
E1	0.485	0.580	12.32	14.73	5
e	0.100 BSC		2.54 BSC		-
e <sub>A</sub>	0.600 BSC		15.24 BSC		6
e <sub>B</sub>	-	0.700	-	17.78	7
L	0.115	0.200	2.93	5.08	4
N	28		28		9

NOTES:

- Controlling Dimensions: INCH. In case of conflict between English and Metric dimensions, the inch dimensions control.
- Dimensioning and tolerancing per ANSI Y14.5M-1982.
- Symbols are defined in the "MO Series Symbol List" in Section 2.2 of Publication No. 95.
- Dimensions A, A1 and L are measured with the package seated in JEDEC seating plane gauge GS-3.
- D, D1, and E1 dimensions do not include mold flash or protrusions. Mold flash or protrusions shall not exceed 0.010 inch (0.25mm).
- E and e<sub>A</sub> are measured with the leads constrained to be perpendicular to datum -C-.
- e<sub>B</sub> and e<sub>C</sub> are measured at the lead tips with the leads unconstrained. e<sub>C</sub> must be zero or greater.
- B1 maximum dimensions do not include dambar protrusions. Dambar protrusions shall not exceed 0.010 inch (0.25mm).
- N is the maximum number of terminal positions.
- Corner leads (1, N, N/2 and N/2 + 1) for E8.3, E16.3, E18.3, E28.3, E42.6 will have a B1 dimension of 0.030 - 0.045 inch (0.76 - 1.14mm).

Rev. 0 12/93

**Small Outline Plastic Packages (SOIC)**

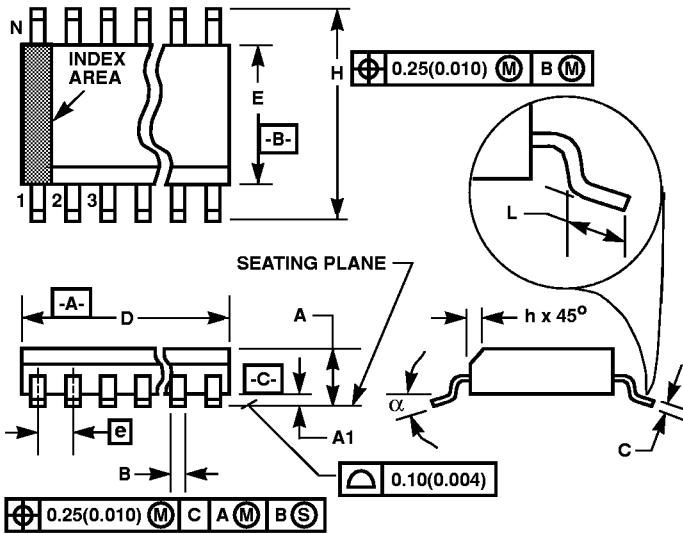

**M28.3 (JEDEC MS-013-AE ISSUE C)**  
**28 LEAD WIDE BODY SMALL OUTLINE PLASTIC PACKAGE**

SYMBOL	INCHES		MILLIMETERS		NOTES
	MIN	MAX	MIN	MAX	
A	0.0926	0.1043	2.35	2.65	-
A1	0.0040	0.0118	0.10	0.30	-
B	0.013	0.0200	0.33	0.51	9
C	0.0091	0.0125	0.23	0.32	-
D	0.6969	0.7125	17.70	18.10	3
E	0.2914	0.2992	7.40	7.60	4
e	0.05 BSC		1.27 BSC		-
H	0.394	0.419	10.00	10.65	-
h	0.01	0.029	0.25	0.75	5
L	0.016	0.050	0.40	1.27	6
N	28		28		7
alpha	0°	8°	0°	8°	-

**NOTES:**

1. Symbols are defined in the "MO Series Symbol List" in Section 2.2 of Publication Number 95.
2. Dimensioning and tolerancing per ANSI Y14.5M-1982.
3. Dimension "D" does not include mold flash, protrusions or gate burrs. Mold flash, protrusion and gate burrs shall not exceed 0.15mm (0.006 inch) per side.
4. Dimension "E" does not include interlead flash or protrusions. Interlead flash and protrusions shall not exceed 0.25mm (0.010 inch) per side.
5. The chamfer on the body is optional. If it is not present, a visual index feature must be located within the crosshatched area.
6. "L" is the length of terminal for soldering to a substrate.
7. "N" is the number of terminal positions.
8. Terminal numbers are shown for reference only.
9. The lead width "B", as measured 0.36mm (0.014 inch) or greater above the seating plane, shall not exceed a maximum value of 0.61mm (0.024 inch)
10. Controlling dimension: MILLIMETER. Converted inch dimensions are not necessarily exact.

Rev. 0 12/93

**Plastic Leaded Chip Carrier Packages (PLCC)**

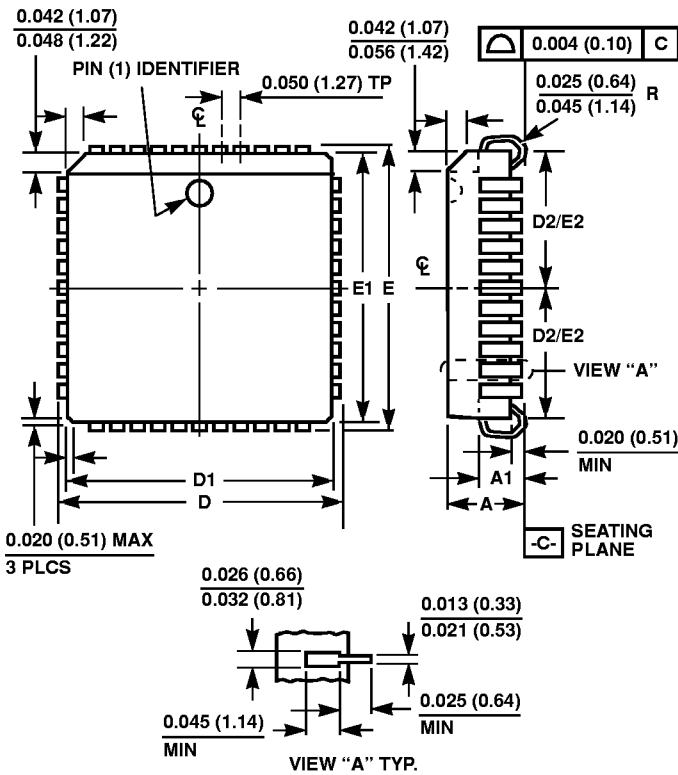

**N44.65 (JEDEC MS-018AC ISSUE A)  
44 LEAD PLASTIC LEADED CHIP CARRIER PACKAGE**

SYM-BOL	INCHES		MILLIMETERS		NOTES
	MIN	MAX	MIN	MAX	
A	0.165	0.180	4.20	4.57	-
A1	0.090	0.120	2.29	3.04	-
D	0.685	0.695	17.40	17.65	-
D1	0.650	0.656	16.51	16.66	3
D2	0.291	0.319	7.40	8.10	4, 5
E	0.685	0.695	17.40	17.65	-
E1	0.650	0.656	16.51	16.66	3
E2	0.291	0.319	7.40	8.10	4, 5
N	44		44		6

Rev. 2 11/97

**NOTES:**

1. Controlling dimension: INCH. Converted millimeter dimensions are not necessarily exact.
2. Dimensions and tolerancing per ANSI Y14.5M-1982.
3. Dimensions D1 and E1 do not include mold protrusions. Allowable mold protrusion is 0.010 inch (0.25mm) per side. Dimensions D1 and E1 include mold mismatch and are measured at the extreme material condition at the body parting line.
4. To be measured at seating plane [-C-] contact point.
5. Centerline to be determined where center leads exit plastic body.
6. "N" is the number of terminal positions.

All Harris Semiconductor products are manufactured, assembled and tested under ISO9000 quality systems certification.

Harris Semiconductor products are sold by description only. Harris Semiconductor reserves the right to make changes in circuit design and/or specifications at any time without notice. Accordingly, the reader is cautioned to verify that data sheets are current before placing orders. Information furnished by Harris is believed to be accurate and reliable. However, no responsibility is assumed by Harris or its subsidiaries for its use; nor for any infringements of patents or other rights of third parties which may result from its use. No license is granted by implication or otherwise under any patent or patent rights of Harris or its subsidiaries.

For information regarding Harris Semiconductor and its products, call 1-800-4-HARRIS or see web site <http://www.semi.harris.com>

**Sales Office Headquarters**

**NORTH AMERICA**  
Harris Semiconductor  
P. O. Box 883, Mail Stop 53-210  
Melbourne, FL 32902  
TEL: 1-800-442-7747  
(407) 727-9207  
FAX: (407) 724-3973

**EUROPE**  
Harris Semiconductor  
Mercure Center  
100, Rue de la Fusee  
1130 Brussels, Belgium  
TEL: (32) 2.724.2111  
FAX: (32) 2.724.22.05

**ASIA**  
Harris Semiconductor PTE Ltd.  
No. 1 Tannery Road  
Cencon 1, #09-01  
Singapore 1334  
TEL: (65) 748-4200  
FAX: (65) 748-0400