

## ISL97519AIUZEVALZ

AN1645  
Rev.1.00  
Mar 3, 2022

### Description

The ISL97519AIUZEVALZ evaluation board is an evaluation kit for evaluating the ISL97519AIUZEVALZ, a step-up voltage regulator that operates with high frequency and high efficiency. This evaluation kit is designed to deliver over 90% efficiency.

The ISL97519AIUZEVALZ kit provides a dip switch that allows users to select either 600kHz or 1.2MHz switching frequency.

### Key Features

- A Complete Evaluation Platform for Evaluation of ISL97519A
- Input Voltage: 2.3V to 5.5V
- Proven Evaluation Board Layout
- Pb-free (RoHS Compliant)

### Pin Configuration

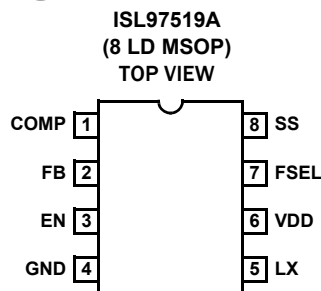

### Ordering Information

PART #	DESCRIPTION
ISL97519AIUZEVALZ	Evaluation Board for ISL97519A

### Quick Setup Guide

- Step 1:** Connect the power supply between the headers of VIN and GND. The positive output of the power supply should be connected to the VIN header. Set the power supply voltage between 2.3V and 5V, and the current limit at 3A.
- Step 2:** Connect the E-load between the headers of VOUT and GND. The positive input of the E-load should be connected to the VOUT header. Set the E-load current. The load current should not exceed the maximum output current that the part can supply.
- Step 3:** Close pins 1 and 4 of S1 to tie the FSEL pin to VIN. This will set the switching frequency to 1.2MHz. Open pins 1 and 4 to pull FSEL to ground with R4 to set the frequency to 600kHz.
- Step 4:** Close pins 2 and 3 of S1 to tie the EN pin to VIN in order to enable the part. To disable the part, open pins 2 and 3 in order to pull EN to ground with R3 to disable the part.

Make sure all the connections on the evaluation board are correct, then turn on the power supply and E-load. The part will start to operate.

### Maximum Output Current

The MOSFET current limit is normally 2.0A and guaranteed at 1.7A. This restricts the maximum output current that the ISL97519A can drive. Table 1 shows the ISL97519AIUZEVALZ maximum output current,  $I_{O\text{MAX}}$  at different input and output voltages.

TABLE 1. TYPICAL MAXIMUM OUTPUT CURRENT

$V_{\text{IN}}$ (V)	$V_{\text{OUT}}$ (V)	$I_{\text{O\text{MAX}}}$ (mA)
2.5	5	870
2.5	9	500
2.5	12	380
3.3	5	1150
3.3	9	655
3.3	12	500
5	9	990
5	12	750

# Board Design Schematic

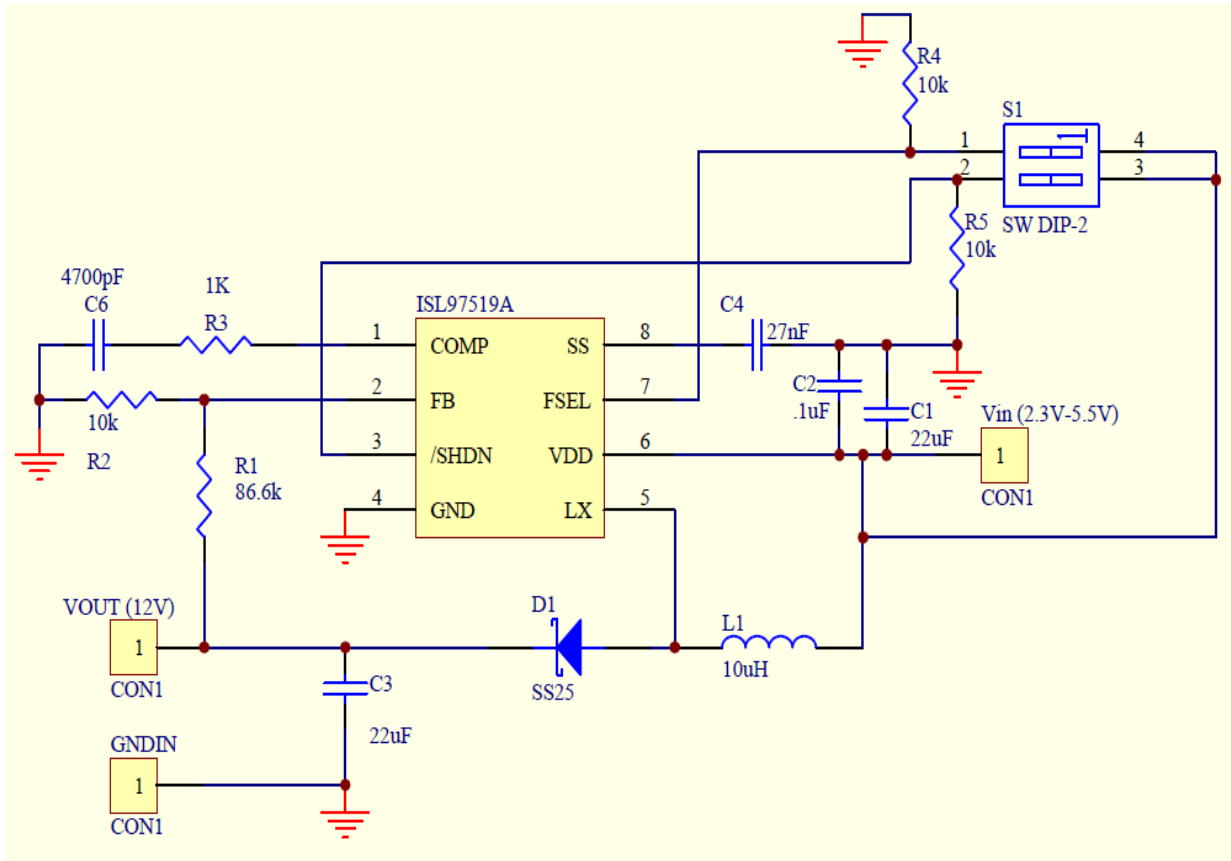

FIGURE 1. SCHEMATIC

## Evaluation Board Layout

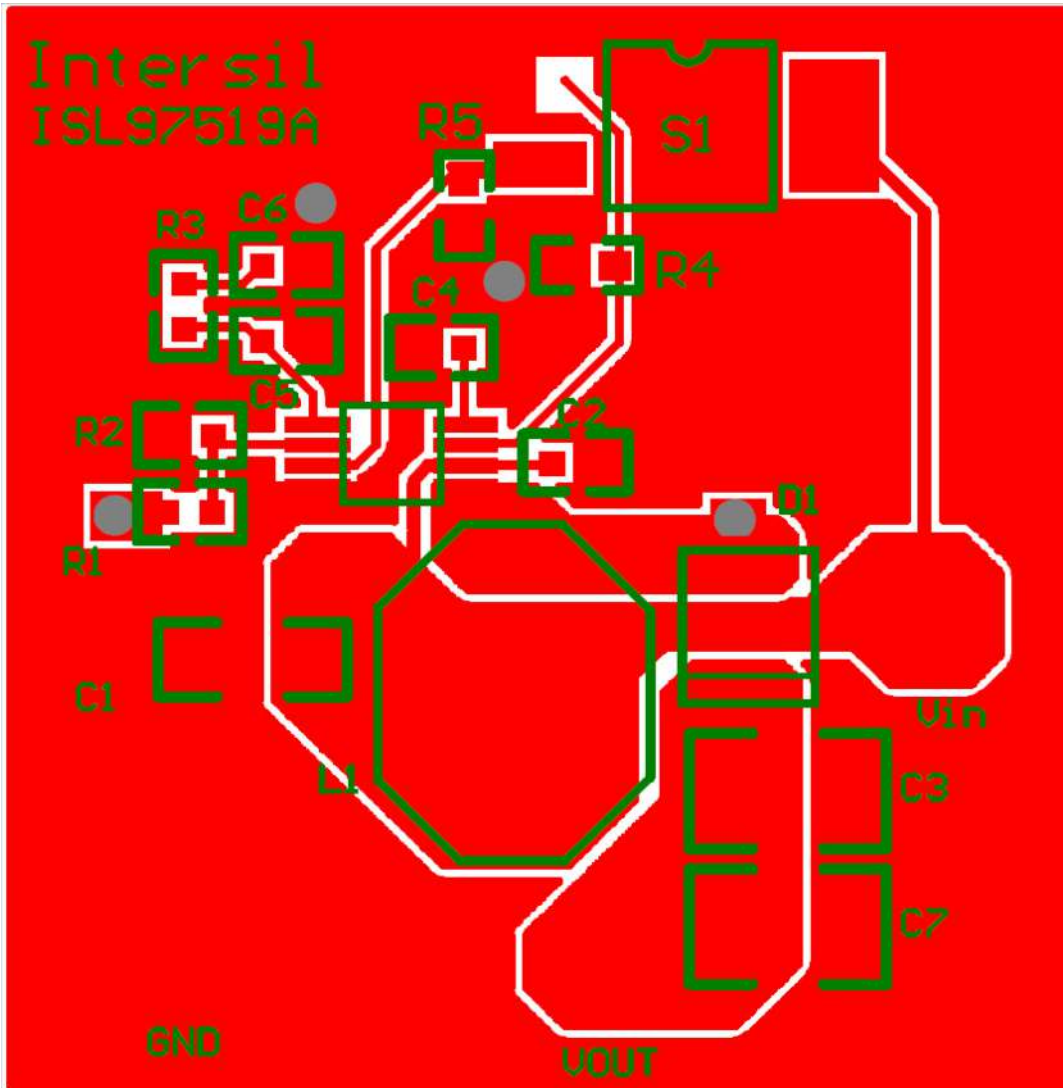

FIGURE 2. EVB ASSEMBLY LAYER

## Evaluation Board Layout (Continued)

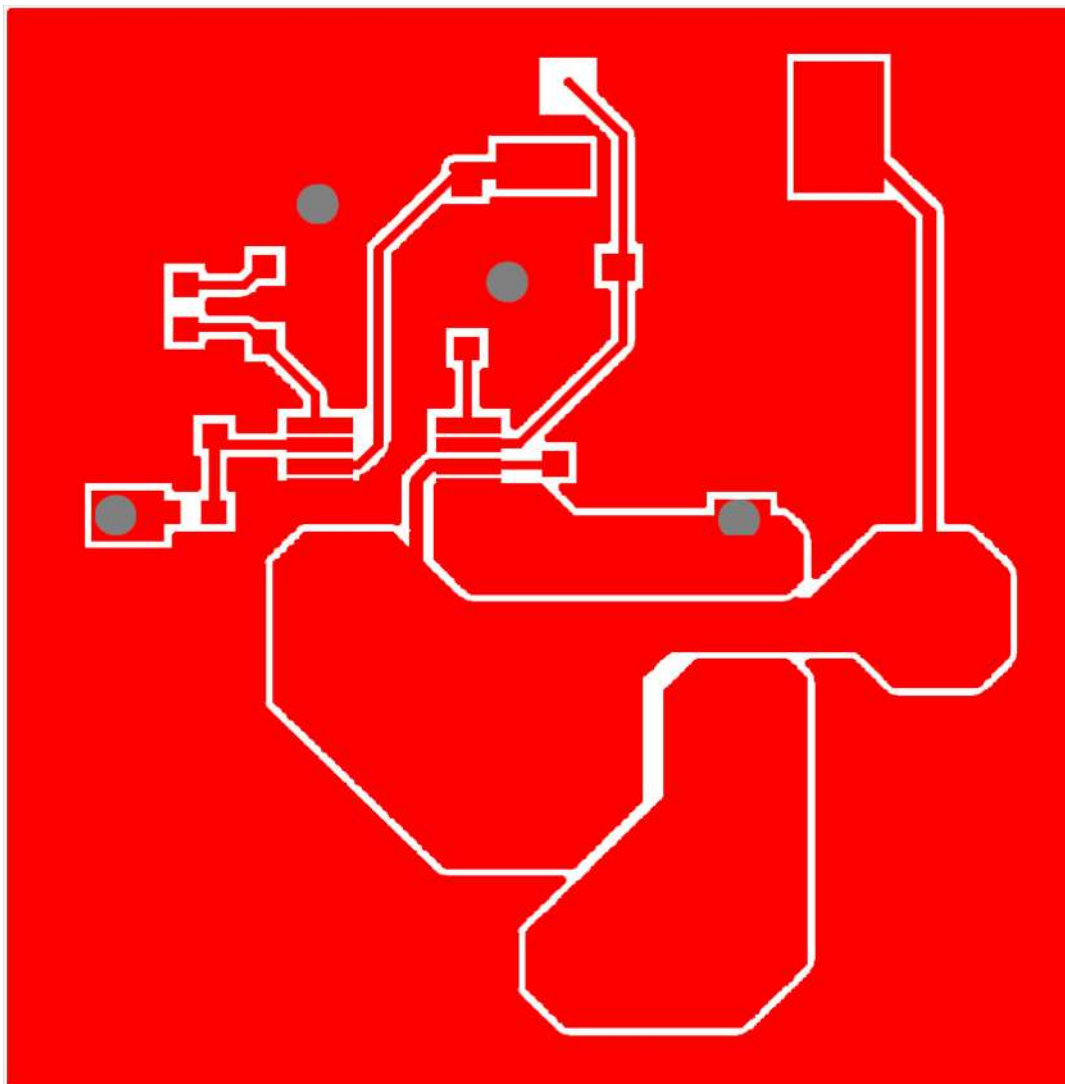

FIGURE 3. TOP LAYER

## Evaluation Board Layout (Continued)

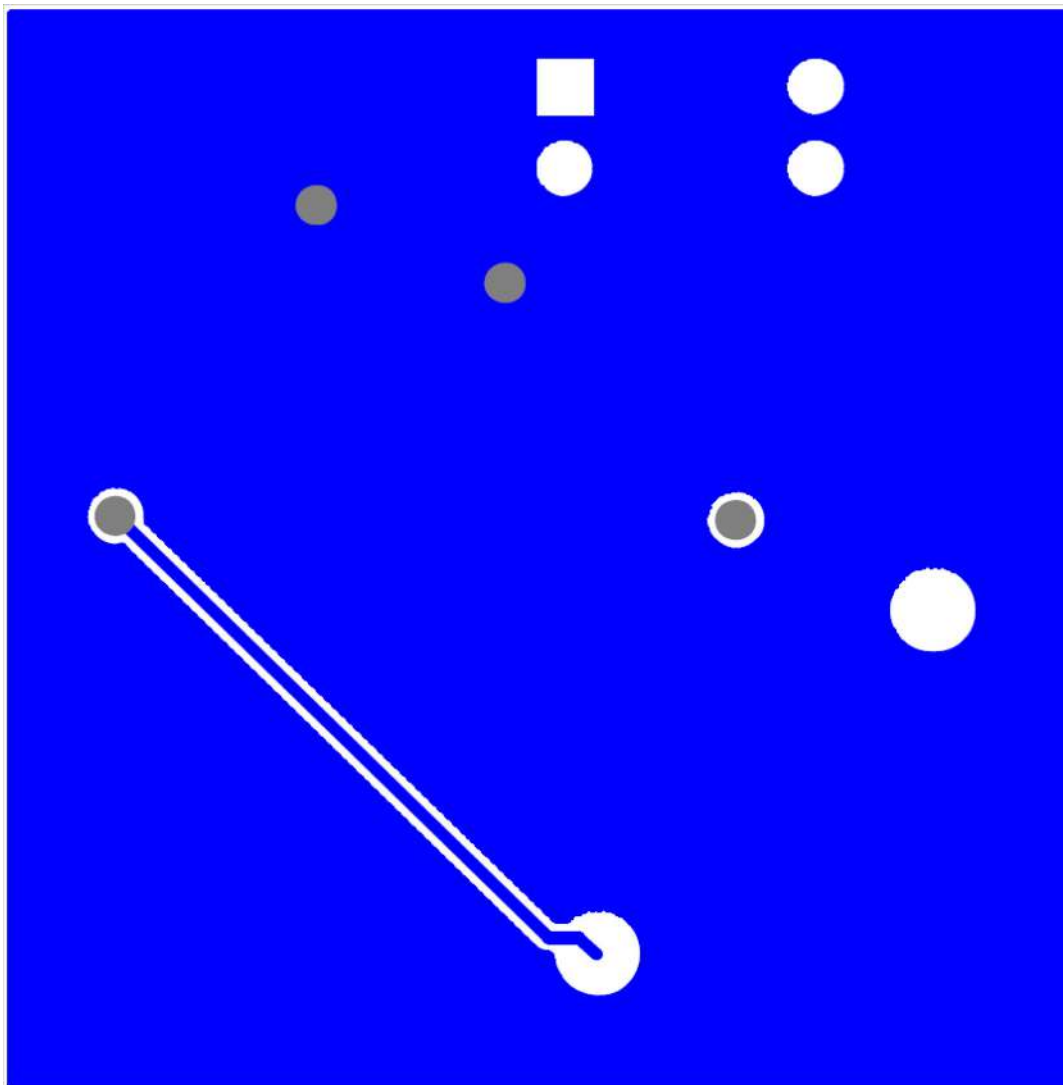

FIGURE 4. BOTTOM LAYER

TABLE 2. ISL97519AIUZEVALZ BILL OF MATERIALS (BOM)

ITEM	QTY	REFERENCE	PART DESCRIPTION	PCB FOOTPRINT	PART NUMBER	VENDOR
1	1	C4	27nF	603		TDK
2	1	C6	4700nF	603		TDK
3	1	C2	0.1μF/16V	603	C1068X7R1H104K	TDK
4	1	R1	86.6k	603		WALSIN
5	3	R2, R4, R5	10k	603	WR06W1002JTL	WALSIN
6	1	R3	1k	603		
8	1	C3	22μF	1206		MURATA
9	1	C1	22μF	1206	GRM31CR61C226KE15L	MURATA
10	1	L1	10μF	CDRH8D43	CDRH8D43NP-100NC	SUMIDA
11	1	U1	ISL97519A	MSOP-8	ISL97519A	INTERSIL
12	1	VOUT (12V)	CON1	Powerpost		
13	1	VIN (3.3V)	CON1	Powerpost		
14	1	GND IN	CON1	Powerpost		
15	1	D1	SS25	DO-214A	SS25	Fairchild
16	1	S1	SWDIP-2	DIP4		CKN3001-ND

## Revision History

DATE	REVISION	CHANGE
Mar 3, 2022	1.00	Corrected BOM information. Updated Ordering part number throughout.
Jul 1, 2011	0.00	Initial Release

## IMPORTANT NOTICE AND DISCLAIMER

RENESAS ELECTRONICS CORPORATION AND ITS SUBSIDIARIES (“RENESAS”) PROVIDES TECHNICAL SPECIFICATIONS AND RELIABILITY DATA (INCLUDING DATASHEETS), DESIGN RESOURCES (INCLUDING REFERENCE DESIGNS), APPLICATION OR OTHER DESIGN ADVICE, WEB TOOLS, SAFETY INFORMATION, AND OTHER RESOURCES “AS IS” AND WITH ALL FAULTS, AND DISCLAIMS ALL WARRANTIES, EXPRESS OR IMPLIED, INCLUDING, WITHOUT LIMITATION, ANY IMPLIED WARRANTIES OF MERCHANTABILITY, FITNESS FOR A PARTICULAR PURPOSE, OR NON-INFRINGEMENT OF THIRD PARTY INTELLECTUAL PROPERTY RIGHTS.

These resources are intended for developers skilled in the art designing with Renesas products. You are solely responsible for (1) selecting the appropriate products for your application, (2) designing, validating, and testing your application, and (3) ensuring your application meets applicable standards, and any other safety, security, or other requirements. These resources are subject to change without notice. Renesas grants you permission to use these resources only for development of an application that uses Renesas products. Other reproduction or use of these resources is strictly prohibited. No license is granted to any other Renesas intellectual property or to any third party intellectual property. Renesas disclaims responsibility for, and you will fully indemnify Renesas and its representatives against, any claims, damages, costs, losses, or liabilities arising out of your use of these resources. Renesas' products are provided only subject to Renesas' Terms and Conditions of Sale or other applicable terms agreed to in writing. No use of any Renesas resources expands or otherwise alters any applicable warranties or warranty disclaimers for these products.

(Rev.1.0 Mar 2020)

### Corporate Headquarters

TOYOSU FORESIA, 3-2-24 Toyosu,  
Koto-ku, Tokyo 135-0061, Japan  
[www.renesas.com](http://www.renesas.com)

### Contact Information

For further information on a product, technology, the most up-to-date version of a document, or your nearest sales office, please visit:  
[www.renesas.com/contact/](http://www.renesas.com/contact/)

### Trademarks

Renesas and the Renesas logo are trademarks of Renesas Electronics Corporation. All trademarks and registered trademarks are the property of their respective owners.