

PRODUCT NUMBER
SEE TABLE

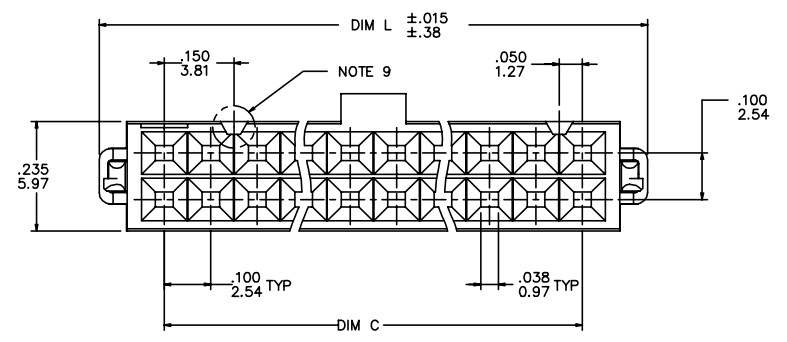
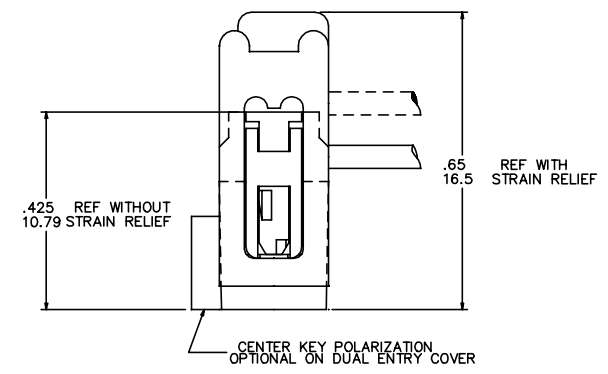
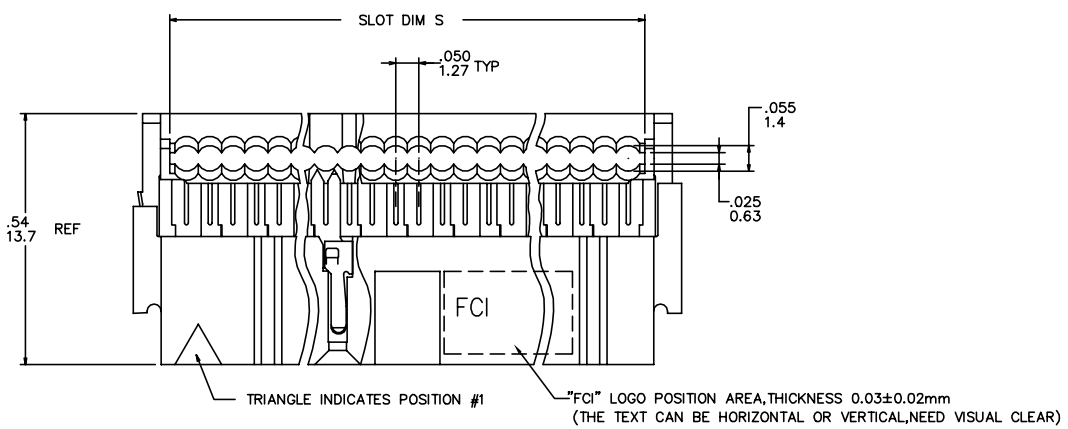
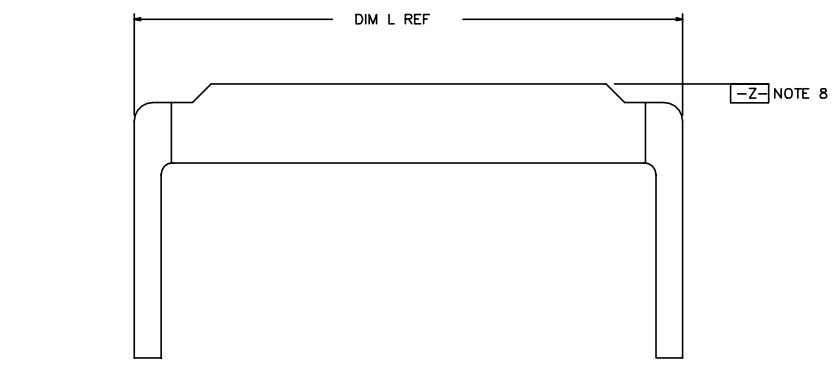

mat'l. code				surface ISO 1302 ✓		tolerance ISO 406 ISO 1101		projection FIRST ANGLE		product family QUICKIE	
ltr	ecn no	dr	date	tolerances unless otherwise specified							
2	NEW	ZK	2013-05-29	angles	linear	.XXX±.01/.XXX±0.3		INCH/MM		title DUAL POLARIZED QUICKIE II ASSEMBLY	
				±2°		.XXX±.005/.XXX±0.13		scale 8:1		dwg no 10125116	
				dr	TIM	04/16/13		FCI		sheet 1 of 2 size A3	
				engr	TIM	04/16/13				type Product Customer Drawing	
				chr	TIM	04/16/13					
				appd	RICK	04/16/13					
sheet index	revision sheet	A	A								
		1	2								

PRODUCT No. NOTE 12	SIZE	DIM L	DIM S	DIM C
10125116-X10	2X5	.680/17.27	.520/13.21	.400/10.16
-X14	2X7	.880/22.35	.720/18.29	.600/15.24
-X16	2X8	.980/24.89	.820/20.83	.700/17.78
-X20	2X10	1.180/29.97	1.020/25.91	.900/22.86
-X24	2X12	1.380/35.05	1.220/30.99	1.100/27.94
-X26	2X13	1.480/37.59	1.320/33.53	1.200/30.48
-X30	2X15	1.680/42.67	1.520/38.61	1.400/35.56
-X34	2X17	1.880/47.75	1.720/43.69	1.600/40.64
-X40	2X20	2.180/55.37	2.020/51.31	1.900/48.26
-X44	2X22	2.380/60.45	2.220/56.39	2.100/53.34
-X50	2X25	2.680/68.07	2.520/64.01	2.400/60.96
10125116-X60	2X30	3.180/80.77	3.020/76.71	2.900/73.66

DASH NO	COVER		POLARIZATION	STRAIN RELIEF
	STYLE	ORIENTATION		
-2XX	THRU	DUAL ENTRY	CENTER KEY & DUAL POL.	YES

COVER ORIENTATION

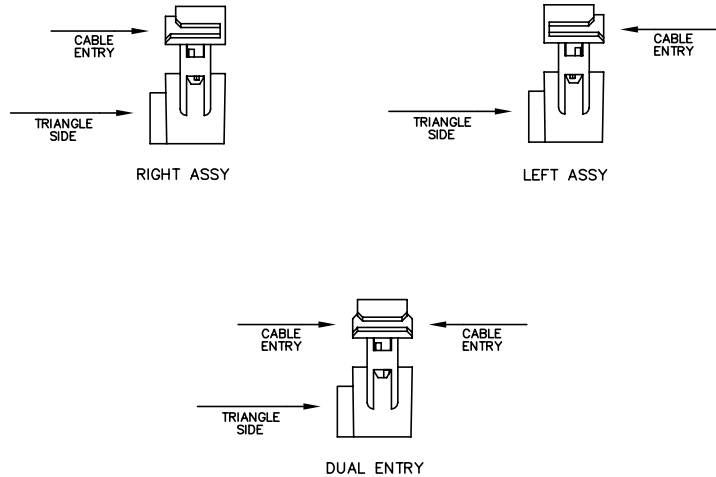

NOTES:

1. TERMINAL MATERIAL: COPPER ALLOY.
2. TERMINAL PLATING: 50u"/1.27u MIN NI UNDERPLATE OVER ENTIRE TERMINAL AND 15u"/.38u MIN Au or GXT IN CONTACT AREA ONLY.
3. MOLDING MATERIAL: BASE & COVER- GLASS FILLED POLYESTER, FLAME RETARDANT PER UL94V-0, COLOR- BLUE.
4. CONNECTOR ASSEMBLIES PACKAGED IN TUBES.
5. THE FIRST TWO CAVITY POSITIONS AND THE LAST TWO, ARE IDENTIFIED BY NUMBER.
6. POLARIZING FEATURES ARE DESCRIBED IN TABLE.
7. MOLDING MATERIAL: STRAIN RELIEF- NYLON, FLAME RETARDANT PER UL94V-0, COLOR- BLUE.
8. STRAIN RELIEF DIM APPLIES WHEN DATUM -Z- IS HELD IN A RESTRAINED CONDITION.
9. THE POLARIZING FEATURE ON THIS END IS NON-EXISTANT ON 2X5 AND 2X7 POSITION CONNECTORS.
10. 2x5 POSITION NOT AVAILABLE WITH POLARIZATION SLOT ON CENTER KEY STYLE.
11. TO ORDER PARTS THAT DO NOT HAVE "MARKED INFO", (DATE, P/N, ETC), ADD A "U" AFTER THE PART NUMBER. EXAMPLE 10125116-010 U.
12. ADD "LF" SUFFIX AT THE END OF PART NUMBER FOR LEAD FREE OPTION.
13. IF "LF" P/N THE PRODUCT MEETS EUROPEAN UNION DIRECTIVES AND OTHER COUNTRY REGULATION AS DESCRIBED IN GS-22-008.
14. THE PRODUCT IS NOT INTENDED TO BE EXPOSED TO A MANUFACTURING SOLDER PROCESS.
15. PRODUCT SPEC. BUS-12-082
16. PLATING OPTIONS: MAY BE EITHER GOLD OR GXT PLATED AT MANUFACTURER'S OPTION.

mat'l. code		surface ISO 1302 ✓	tolerance ISO 406 ISO 1101	projection INCH/MM	product family QUICKIE
ltr	ecn no	dr	date	tolerances unless otherwise specified	title
A				angles linear XXX±.01/XXX.3 XXX±.005/XXX.013 XXX±.0020/XXX±0.051	DUAL POLARIZEO QUICKIE II ASSEMBLY
				±2"	scale 1:1
		dr	TIM	04/16/13	dwg no
		enrg	TIM	04/16/13	sheet 2 of 2
		chr	TIM	04/16/13	size
		appd	RICK	04/16/13	10125116
					A3
					type Product Customer Drawing
sheet index	revision sheet				