



On Delay Solid State Timer

MCS

Specifications

Electrical

Input Voltage: 24 to 240V, ±10%

Frequency: AC - 50/60Hz

DC - Filtered to Full Wave

Time Delays:

Type: Adjustable, Factory Fixed or Remote

Range: 100 Milliseconds to 5 Minutes

Repeat Accuracy: ±1% with Fixed Conditions

Fixed Time Accuracy: ±20% worst Case

Reset Times:

During Timing: 50 Milliseconds, Typical

After Timing: 5 Milliseconds, Typical

Protection: Varistor and/or R-C Network

Power Consumption: 5VA

Output Ratings:

Type: Solid State

Form: One Normally Open (1NO, Form A)
Non-Isolated

Rating: 1 Amp Continuous @ 25°C

Resistive: 100%PF

Inductive: 75-80%PF

15 Amps Inrush, Non-repetitive

30 mAmps to ensure Turn-on

Operations: 100,000 Cycles*

* Cycles were selected to satisfy minimum testing at UL.

Physical

Mounting: Surface, #6 Screws

Termination:

Screw or .25" Push-On Tabs

Packaging: Epoxy Filled

Weight: 4 Oz.

Ambient Temperatures

Operating: 0°C to 65°C

UL Operating: 0°C to 40°C

Storage: -30°C to 85°C

Notes:

Remote Timing Resistors - multiples of 2.7 megohms will increase the time delay by 1 minute ±20%.

For adjustment codes 3 & 4 a jumper or resistor must be installed across terminals 3 and 4 to allow the timer to time out.



- 1 Amp Output, 1NO
- Indicating LED
- Fixed or Adjustable Delays
- Screw Terminals or Push-On Tabs
- Voltages from 24 to 240VAC
- Epoxy Filled

Ordering Information

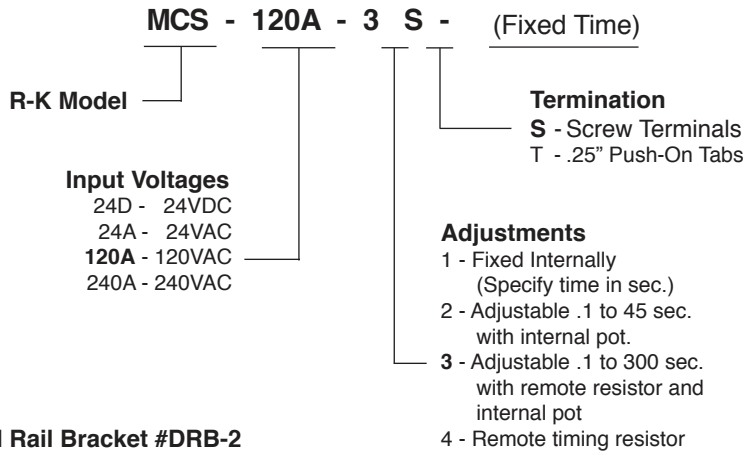

DIN Rail Bracket #DRB-2



Operation

On Delay

When input power is applied to the MCS, the timing cycle begins. At the end of the timed period the load is energized. When input power is removed, the timing circuit is reset and the load is de-energized.

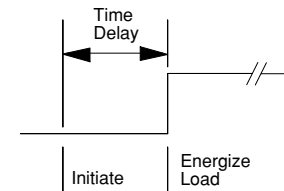

Connections

The MCS operates with the Load in series with the timer. A Load must always be connected in series with the MCS to avoid damage.

MS = Load (Motor Starter)

C1 = Control Contact

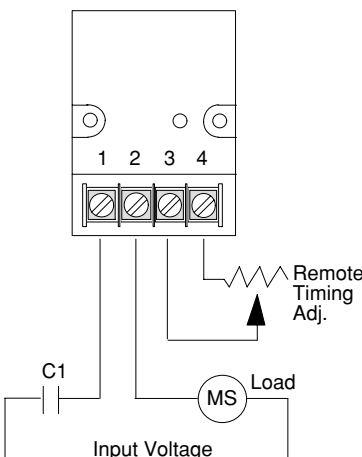

Dimensions

