

LEAD-FREE PART NUMBER	PCB THICKNESS	DIM A	DIM B	CURRENT RATING	MATING LENGTH
70201-001LF	1.6	5.90	5.58	40 Amps. Max.	8
70201-002LF	2.4	6.70	6.38	40 Amps. Max.	8
70201-003LF	3.2	7.50	7.18	40 Amps. Max.	8
70201-004LF	4.0	8.30	7.98	40 Amps. Max.	8
70201-005LF	4.8	9.10	8.78	40 Amps. Max.	8
70201-006LF	5.6	9.90	9.58	40 Amps. Max.	8
70201-007LF	3.7	8.00	7.68	40 Amps. Max.	8

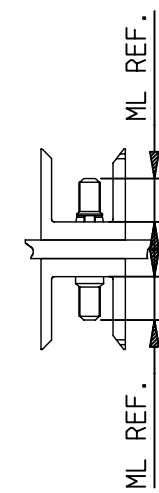
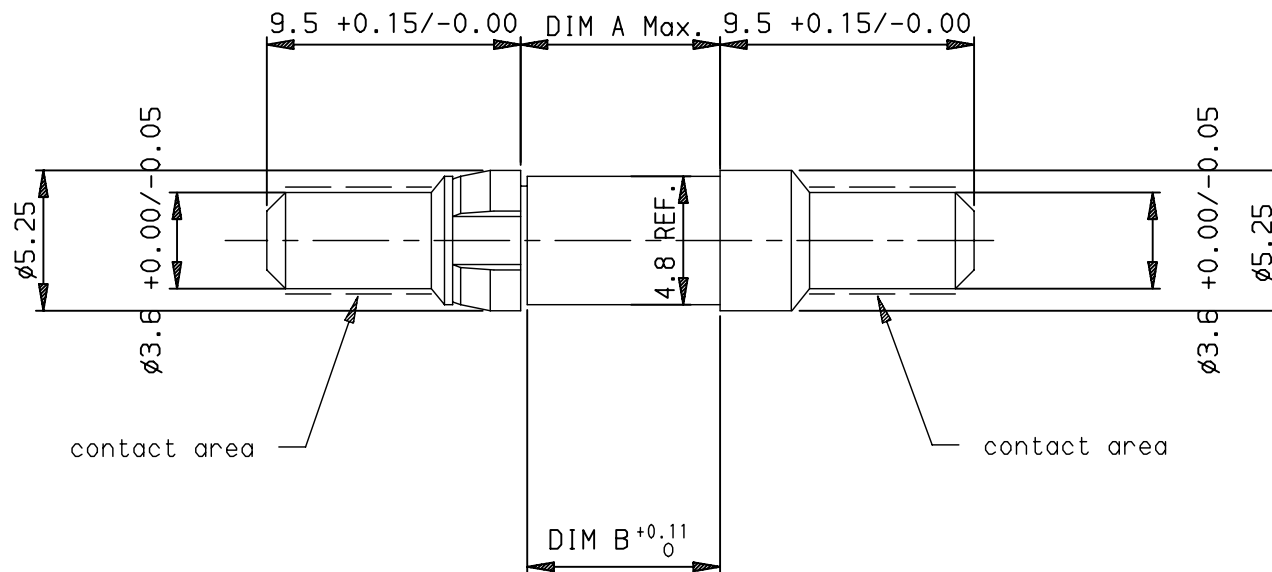

APPLICATION SCALE 1:1

NOTES:

- 1 UNDERPLATING Ni
- 2 DIM. ACC. DIN 41626 UNLESS OTHERWISE STATED
- 3 GEN. TOL. ±0.10
- 4 CAN BE USED WITH NARROW/WIDE BODY HOUSINGS LIKE 70290/88911
- 5 THIS PRODUCT WITH "LF" SUFFIX MEETS EUROPEAN UNION DIRECTIVES AND OTHER COUNTRY REGULATIONS AS DESCRIBED IN GS -22-008.
- 6 THE PRODUCT IS NOT INTENDED TO BE EXPOSED TO A MANUFACTURE AND SOLDER PROCESS.
- 7 PACKAGING SPEC: SEE GS-14-920

CONTACT AREA
1.3µm Au Min.

rev	ecn no	dr	date
K	LS06-0022	LGO	2006/03/04
L	LS07-0214	LGO	2007/08/20
M	LS08-0057	LGO	2008/02/18
-	-	-	-
-	-	-	-
-	-	-	-

www.fciconnect.com		surface	tolerance std	projection	mm
		ISO 1302	ISO 406 ISO 1101		
TOLERANCES UNLESS OTHERWISE SPECIFIED					
Dr	GOISNARD	2006/03/04	ANGULAR	0.X ±0.1	size A3
Eng	GOISNARD	2006/03/04	LINEAR	0.XX ±0.1	Scale 5
Chr	LEGARE	2006/03/04	0.XX ±2	0.XXX ±0.1	ECN LS08-0057
Appr	LEGARE	2006/03/04	Product family	METRAL	Spec ref -
		HEADER		70201	Rev. M
		POWER COUPLER		70201	M
catalog no				CUSTOMER	sheet 1 of 2

European Views

LEAD-FREE PART NUMBER	PCB THICKNESS	DIM A		DIM B		DIM C	DIM D	CURRENT RATING	MATING LENGTH
		MIN.	MAX.	MIN.	MAX.				
70201-101LF	2.5-5.0	6.2	9.6	22.2	25.6	4.9	8	40 Amps. Max.	6.5
70201-102LF	4.5-7.0	8.1	11.5	23.35	26.75	4.15	7.25	40 Amps. Max.	5.75

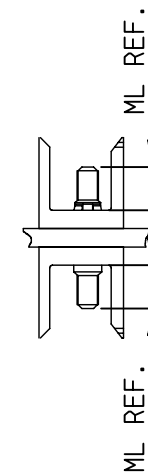

APPLICATION SCALE 1:1

CONTACT AREA
1.3µm Au Min.

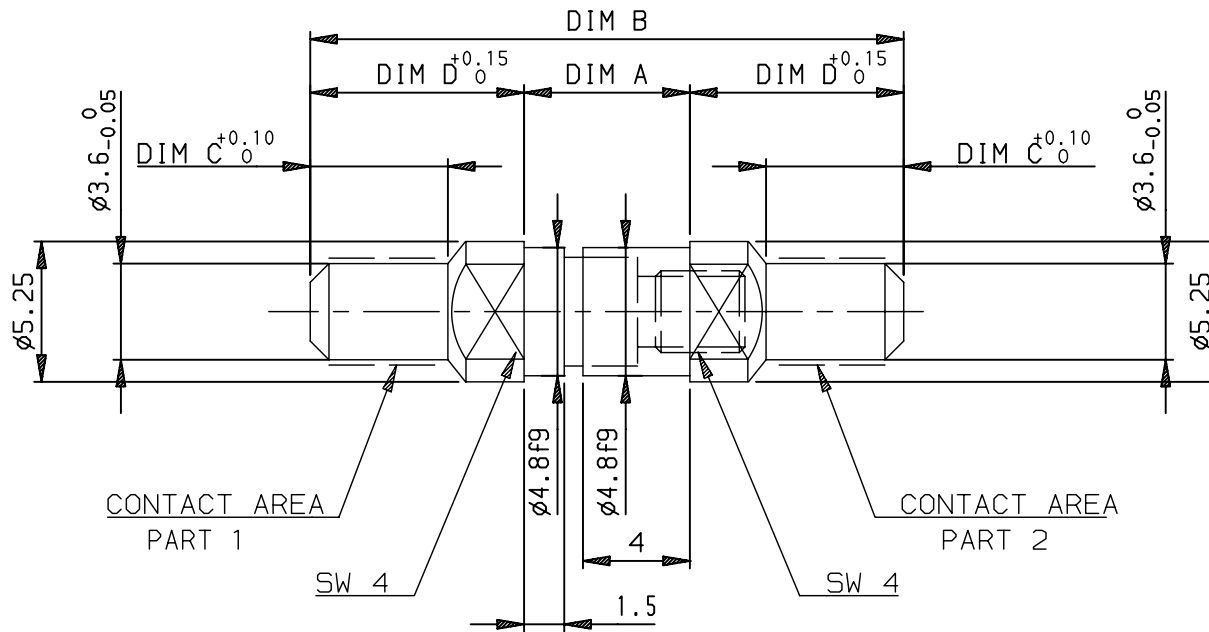

- NOTES:
- 1 UNDERPLATING Ni
 - 2 DIM. ACC. DIN 41626 UNLESS OTHERWISE STATED
 - 3 GEN. TOL. ±0.10
 - 4 CAN BE USED WITH NARROW/WIDE BODY HOUSINGS LIKE 70290/88911
 - 5 THIS PRODUCT WITH "LF" SUFFIX MEETS EUROPEAN UNION DIRECTIVES AND OTHER COUNTRY REGULATIONS AS DESCRIBED IN GS -22-008.
 - 6 THE PRODUCT IS NOT INTENDED TO BE EXPOSED TO A MANUFACTURE AND SOLDER PROCESS.
 - 7 PACKAGING SPEC: SEE GS-14-920

European Views

www.fciconnect.com		surface ISO 1302	tolerance std ISO 406 ISO 1101	projection mm	mm
		TOLERANCES UNLESS OTHERWISE SPECIFIED		ANGULAR	LINEAR
Dr	GOISNARD	2006/03/04	0.X	±0.1	size A3
Eng	GOISNARD	2006/03/04	0.XX	±0.1	Scale 5
Chr	LEGARE	2006/03/04	0.XX' ±2'	0.XXX	±0.1
Appr	LEGARE	2006/03/04	Product family METRAL		ECN LS08-0057
		Spec ref -			
FCI title HEADER POWER COUPLER		70201		Rev. M	
catalog no -		CUSTOMER		sheet 2 of 2	