

NOTES:

1. MOUNTING TYPE: SCREW.
2. VOLTAGE: 600 V (UL).
3. CURRENT: Cu 380 A, Al 310 A (UL).
3. WIRE CROSS-SECTION RANGE, UL:
Cu/Al 3/0 AWG - 500mm² (85 - 500mm²) STRANDED
3X 1/0-2 AWG (3X 53-33.6mm²) STRANDED
2X 2/0-2 AWG (2X 67-33.6mm²) STRANDED
4. HEAD CAP SCREW WITH 8mm HEXAGON SOCKET SIZE.
5. RECOMMENDED TIGHTENING TORQUE:
360 Lb-In (40Nm).
6. ALL ELECTRICAL AND MECHANICAL SPECIFICATIONS ARE PER UL1059 AS NOTED IN MOLEX UL AGENCY APPROVAL.
7. THE SUITABILITY OF THESE TERMINALS SHALL BE DETERMINED IN THE END-USE INVESTIGATION.
8. AS ENVIRONMENTAL BARRIER DIELECTRIC GREASE MAY BE PRESENT IN THE WIRING CHAMBER. ENSURE TO USE THE RECOMMENDED TIGHTING TORQUE FOR ALL CONDUCTORS.

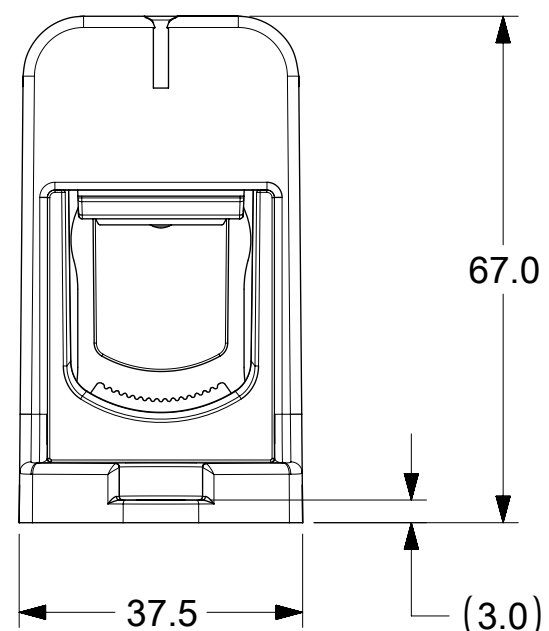
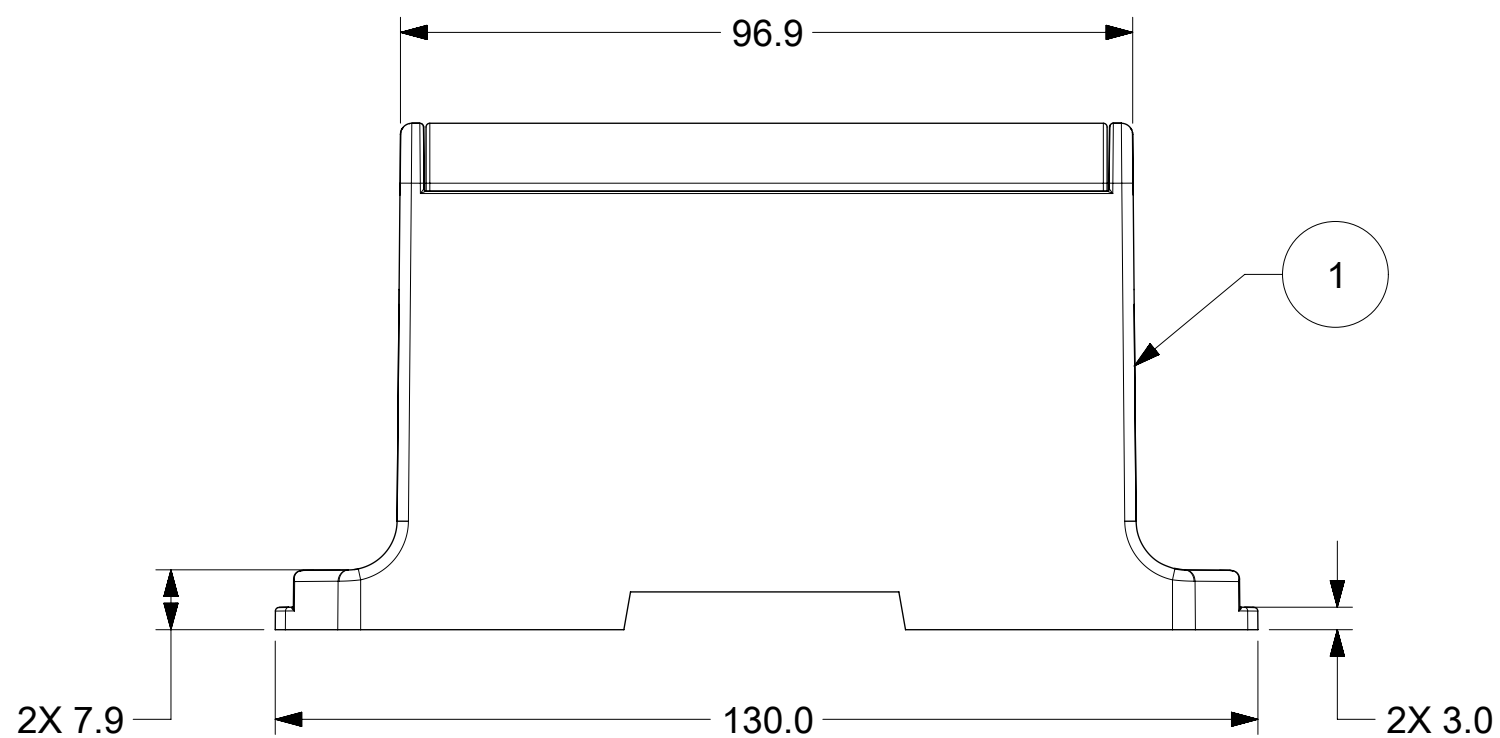
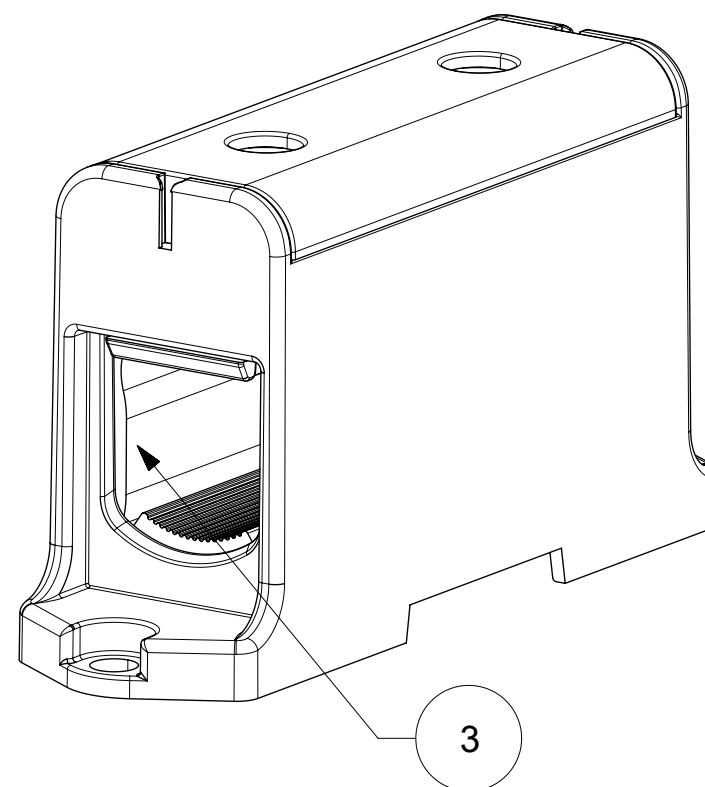
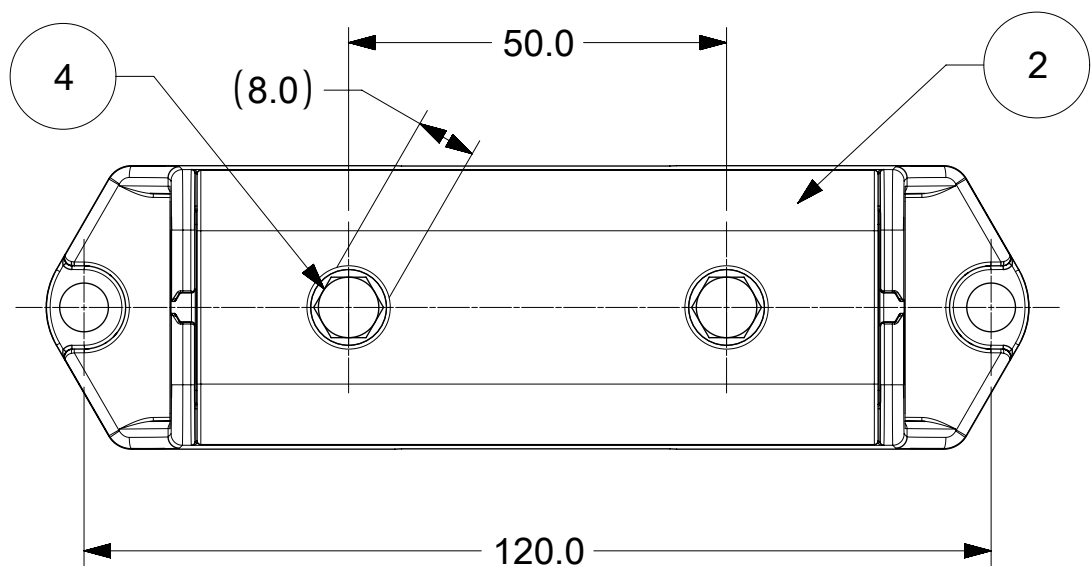

ITEM	QTY	DESCRIPTION	MATERIAL
4	2	SCREW, SET	ALUMINUM
3	1	CAGE	ALUMINUM
2	1	COVER	POLYAMIDE
1	1	HOUSING	POLYAMIDE

2016060643	MX-KE64.3	UCLP 1PL GRN/YLW 380A	GREEN	YELLOW
2016060642	MX-KE64.2	UCLP 1PL GRY/BLU 380A	GREY	BLUE
2016060640	MX-KE64	UCLP 1PL GRY/GRY 380A	GREY	GREY
MATERIAL No.	ENGINEERING No.	DESCRIPTION	HOUSING COLOR	COVER COLOR

THIS DRAWING CONTAINS INFORMATION THAT IS PROPRIETARY TO MOLEX ELECTRONIC TECHNOLOGIES, LLC AND SHOULD NOT BE USED WITHOUT WRITTEN PERMISSION

EC NO: 120665 DRWN: WLEUNG CHKD: DNGUYEN62 APPR: JFMURPHY	2017/08/14 2017/08/15 2017/08/18	GENERAL TOLERANCES (UNLESS SPECIFIED) ANGULAR TOL ± °	DIMENSION UNITS: mm SCALE: 1:1	
	4 PLACES ± 3 PLACES ± 2 PLACES ± SEE CHART 1 PLACE ± SEE CHART 0 PLACES ±	DRWN BY: WLEUNG DATE: 2017/08/14 CHKD BY: DNGUYEN62 DATE: 2017/08/15 APPR BY: JFMURPHY DATE: 2017/08/18	PRODUCT CUSTOMER DRAWING	
	DRAFT WHERE APPLICABLE MUST REMAIN WITHIN DIMENSIONS	DRAWING SIZE: C THIRD ANGLE PROJECTION	SERIES: 201606 MATERIAL NUMBER: SEE CHART CUSTOMER:	
	DOCUMENT NUMBER: 2016060640 DOC TYPE: PSD DOC PART: 000 SHEET NUMBER: 1 OF 1			

TOLERANCE	>0.5=3	>3=6	>6=30	>30=120	>120=400
ISO 2768-m	±0.1	±0.1	±0.2	±0.3	±0.5