

## Demonstration board for STGAP2HSM isolated 4 A single gate driver



### Features

- **Board**
  - High voltage rail up to 1200 V
  - Negative gate driving
  - Onboard isolated DC-DC converters to supply high-side and low-side gate drivers, fed by VAUX = 5 V, with 5.2 kV maximum isolation
  - 3.3 V VDD logic supply generated onboard or 5 V (externally applied)
  - Easy jumper selection of driving voltage configuration: +15/0 V; +15/-3 V; +19/0 V; +19/-3 V;
- **Device**
  - Driver current capability: 4 A source/sink @ 25°C
  - Separate sink and source for easy gate driving configuration
  - 6000 V Galvanic isolation
  - Short propagation delay: 75 ns
  - UVLO function
  - Gate driving voltage up to 26 V
  - 3.3 V, 5 V TTL/CMOS inputs with hysteresis
  - Temperature shutdown protection
  - Standby function

Product status link

[EVALSTGAP2HSM](#)

### Description

The [EVALSTGAP2HSM](#) is an isolated single gate driver.

The gate driver is characterized by 4 A current capability and rail-to-rail outputs, making the device suitable also for high power inverter applications such as motor drivers in industrial applications equipped with MOSFET / IGBT power switch.

The separated source and sink outputs allow to independently optimize turn-on and turn-off by using dedicated gate resistors.

The device integrates protection functions: UVLO and thermal shutdown are included to easily design high reliability systems. Dual input pins allow choosing the control signal polarity and also implementing HW interlocking protection in order to avoid cross-conduction in case of controller's malfunction.

The device allows implementing negative gate driving, and the onboard isolated DC-DC converters allow working with optimized driving voltage for MOSFET/IGBT.

The EVALSTGAP2HSM board allows evaluating all the STGAP2HSM features while driving a half-bridge power stage with voltage rating up to 1200 V in TO-220 or TO-247 package.

The board allows easily selecting and modifying the values of relevant external components in order to ease driver performance evaluation under different applicative conditions and fine pre-tuning of the final application's components.

# 1 Schematic diagram

Figure 1. EVALSTGAP2HSM circuit schematic – gate drivers

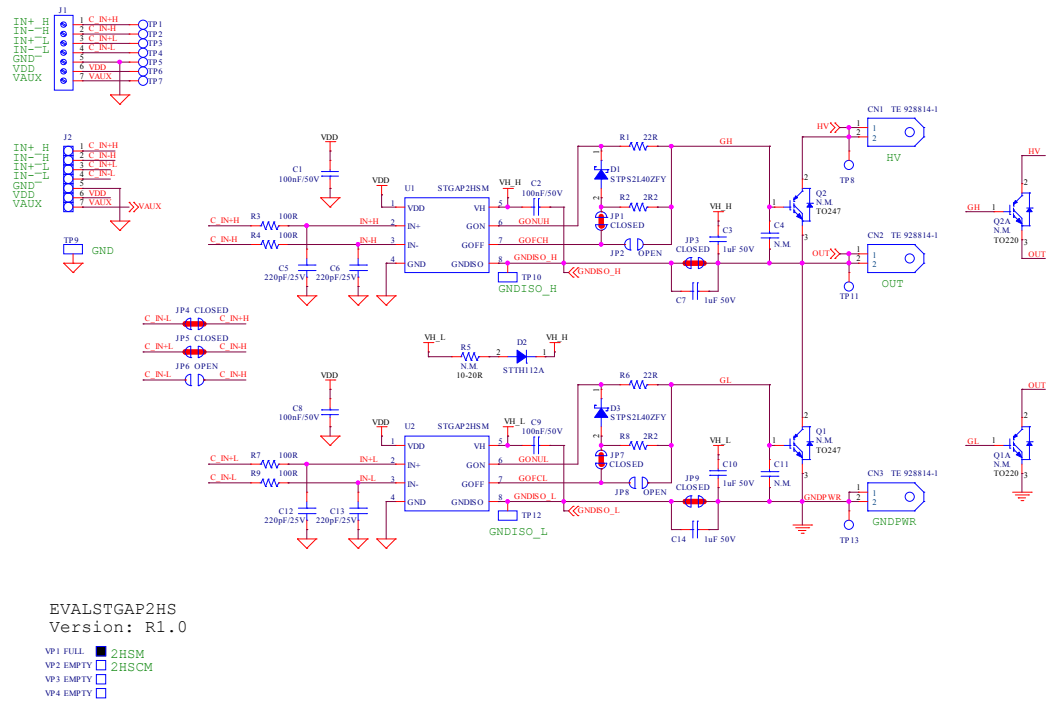

**Figure 2. EVALSTGAP2HSM circuit schematic – supply, connectors and decoupling**

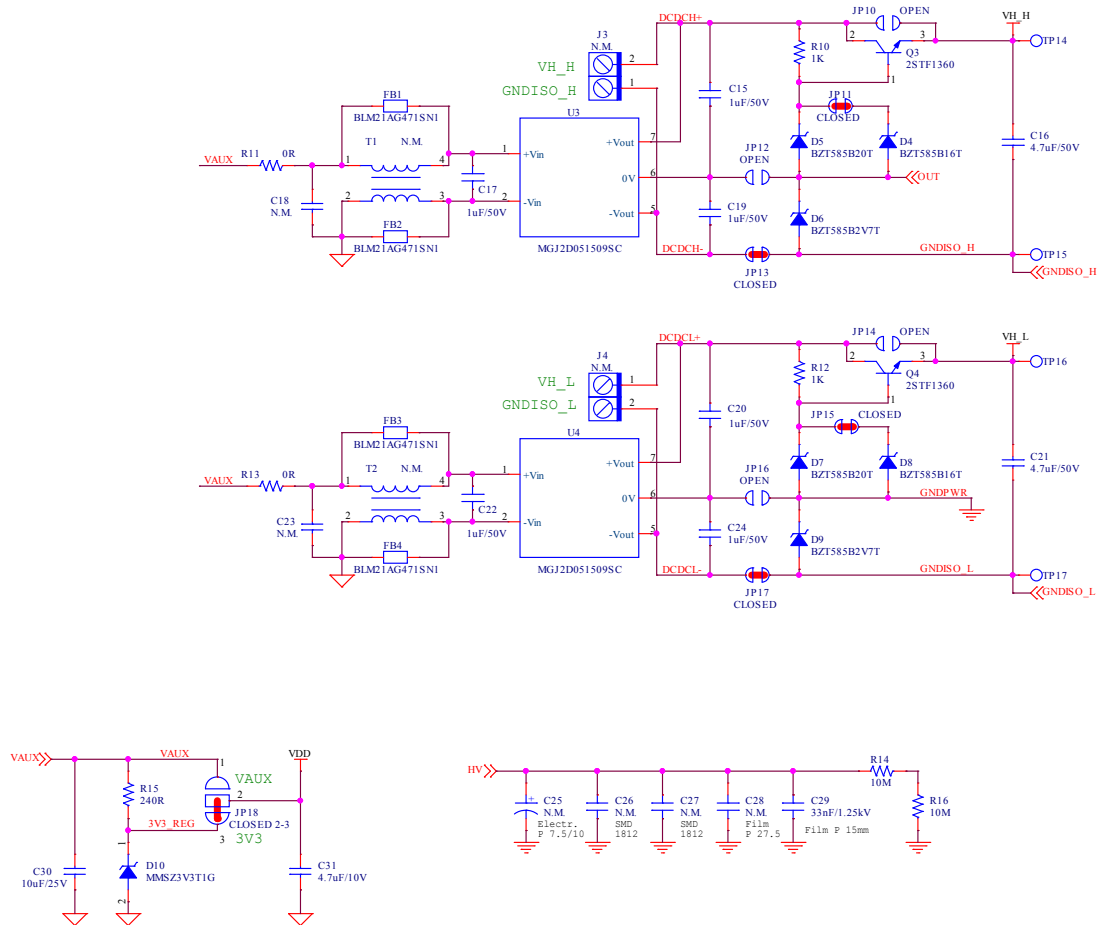

## 2 Bill of material

**Table 1. Bill of Material – components common to all device variants**

Reference	Description	Value / Generic Part Number
CN1,CN2,CN3	Tab FASTON 250 horizontal	TE 928814-1
C1,C2,C8,C9	SMT ceramic capacitor	100 nF/50 V
C3,C7,C10,C14	SMT ceramic capacitor	1 uF/50 V
C4,C11	SMT ceramic capacitor	N.M.
C5,C6,C12,C13	SMT ceramic capacitor	220 pF/25 V
C15,C17,C19,C20,C22,C24	SMT ceramic capacitor	1 uF/50 V
C16,C21	SMT ceramic capacitor	4.7 uF/50 V
C18,C23	SMT ceramic capacitor	N.M.
C25	THT electrolytic capacitor	N.M.
C26,C27	SMT ceramic capacitor	N.M.
C28	Film capacitor	N.M.
C29	Film capacitor	33 nF/1.25k V
C30	SMT ceramic capacitor	10 uF/25 V
C31	SMT ceramic capacitor	4.7 uF/10 V
D1,D3	Automotive low drop power Schottky rectifier	STPS2L40ZFY
D2	High voltage ultrafast rectifier	STTH112A
D4,D8	Surface mount precision Zener diode	BZT585B16T
D5,D7	Surface mount precision Zener diode	BZT585B20T
D6,D9	Surface mount precision Zener diode	BZT585B2V7T
D10	Zener voltage regulator 500 mW	MMSZ3V3T1G
FB1,FB2,FB3,FB4	Ferrite beads	BLM21AG471SN1
JP1,JP3,JP4,JP5,JP7,JP9,JP11,JP13,JP15,JP17	SMT jumper	Closed
JP2,JP6,JP8,JP10,JP12,JP14,JP16	SMT jumper	Open
JP18	SMT jumper	Closed 2-3
J1	Connector terminal block T.H. 7 POS 3.5 mm	MORSV-350-7P_screw
J2	Strip connector 7 POS, 2.54 mm	STRIP 1x7
J3,J4	Connector terminal block T.H. 2 POS 5.08 mm	N.M.
Q1,Q2	N-channel IGBT or MOSFET up to 1700 V	N.M.
Q1A,Q2A	N-channel IGBT or MOSFET up to 1700 V	N.M.
Q3,Q4	Low voltage fast-switching NPN power transistors	2STF1360
R1,R6	SMT resistor	22R
R2,R8	SMT resistor	2R2
R3,R4,R7,R9	SMT resistor	100R
R5	SMT resistor	N.M.
R10,R12	SMT resistor	1K
R11,R13	SMT resistor	0R

Reference	Description	Value / Generic Part Number
R14,R16	SMT resistor	10M
R15	SMT resistor	240R
TP1,TP2,TP3,TP4,TP5,TP6,TP7,TP8,TP11,TP13,TP14,TP15,TP16,TP17	Test point - PCB 1.5 mm diameter	T POINT R
TP9,TP10,TP12	THT Ring test point	TPTH-ANELLO-1MM
T1,T2	Common mode choke, SMD 4.7x4.5 mm	N.M.
U1,U2	Galvanically isolated 4 A single gate driver	STGAP2HSM
U3,U4	5.2KVDC isolated 2W Gate Drive DC-DC converters	MGJ2D051509SC
VP1	PCB assembly version solder dot	Full
VP2,VP3,VP4	PCB assembly version solder dot	Empty
	P.C.B. EVALSTGAP2HS Rev.1	

### 3 Layout and component placements

**Figure 3. EVALSTGAP2HSM – Layout (component placement top view)**

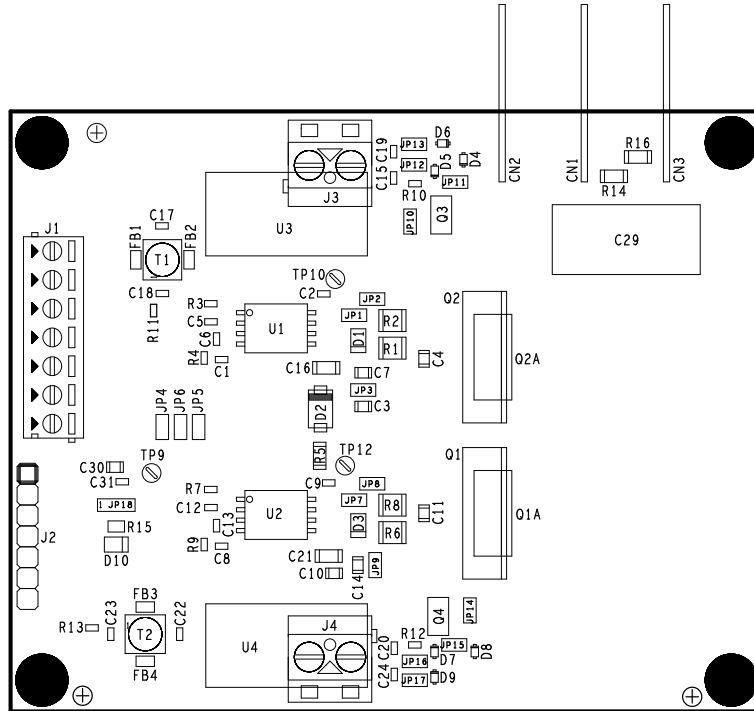

**Figure 4. EVALSTGAP2HSM – Layout (component placement bottom view)**

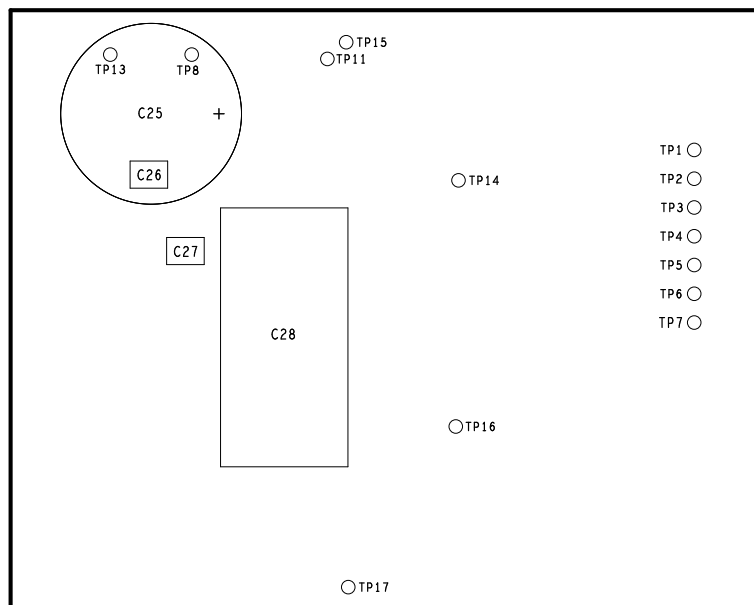

**Figure 5. EVALSTGAP2HSM – Layout (top layer)**

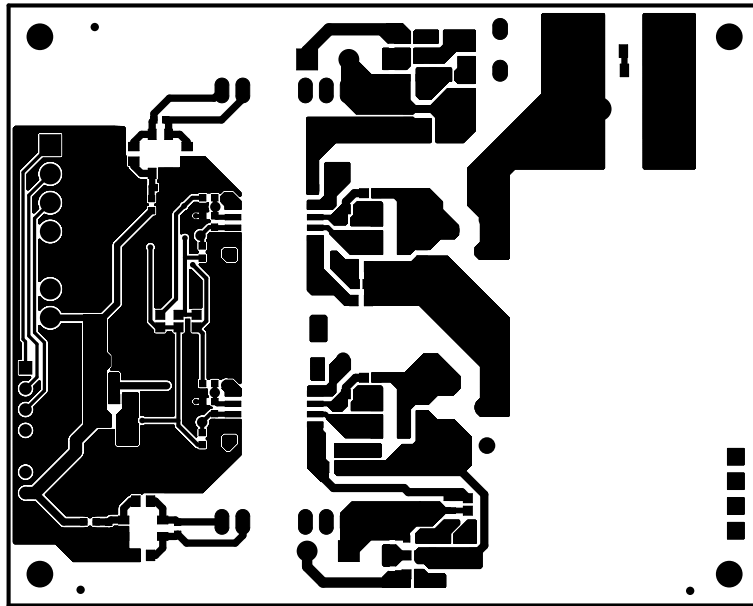

**Figure 6. EVALSTGAP2HSM – Layout (bottom layer)**

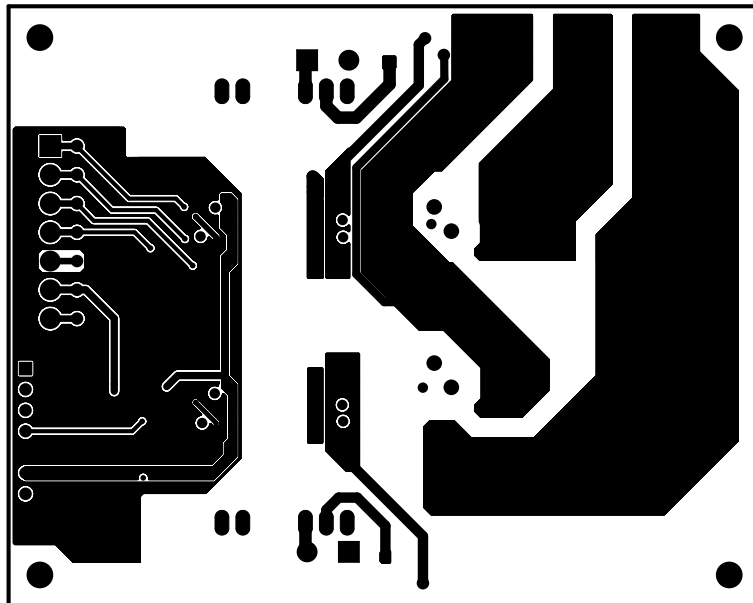

## Revision history

**Table 2. Document revision history**

Date	Version	Changes
08-Sep-2020	1	Initial release.



## Contents

<b>1</b>	<b>Schematic diagram</b> .....	<b>2</b>
<b>2</b>	<b>Bill of material</b> .....	<b>4</b>
<b>3</b>	<b>Layout and component placements</b> .....	<b>6</b>
	<b>Revision history</b> .....	<b>8</b>
	<b>Contents</b> .....	<b>9</b>
	<b>List of tables</b> .....	<b>10</b>
	<b>List of figures</b> .....	<b>11</b>

## List of tables

<b>Table 1.</b>	Bill of Material – components common to all device variants . . . . .	4
<b>Table 2.</b>	Document revision history . . . . .	8

## List of figures

<b>Figure 1.</b>	EVALSTGAP2HSM circuit schematic – gate drivers. . . . .	2
<b>Figure 2.</b>	EVALSTGAP2HSM circuit schematic – supply, connectors and decoupling . . . . .	3
<b>Figure 3.</b>	EVALSTGAP2HSM – Layout (component placement top view) . . . . .	6
<b>Figure 4.</b>	EVALSTGAP2HSM – Layout (component placement bottom view) . . . . .	6
<b>Figure 5.</b>	EVALSTGAP2HSM – Layout (top layer) . . . . .	7
<b>Figure 6.</b>	EVALSTGAP2HSM – Layout (bottom layer) . . . . .	7

**IMPORTANT NOTICE – PLEASE READ CAREFULLY**

STMicroelectronics NV and its subsidiaries (“ST”) reserve the right to make changes, corrections, enhancements, modifications, and improvements to ST products and/or to this document at any time without notice. Purchasers should obtain the latest relevant information on ST products before placing orders. ST products are sold pursuant to ST’s terms and conditions of sale in place at the time of order acknowledgement.

Purchasers are solely responsible for the choice, selection, and use of ST products and ST assumes no liability for application assistance or the design of Purchasers’ products.

No license, express or implied, to any intellectual property right is granted by ST herein.

Resale of ST products with provisions different from the information set forth herein shall void any warranty granted by ST for such product.

ST and the ST logo are trademarks of ST. For additional information about ST trademarks, please refer to [www.st.com/trademarks](http://www.st.com/trademarks). All other product or service names are the property of their respective owners.

Information in this document supersedes and replaces information previously supplied in any prior versions of this document.

© 2020 STMicroelectronics – All rights reserved