

General Description

The AOZ6683CI is a high efficiency, easy to use, 3A synchronous buck regulator at high switching frequency for small form factor solution. The AOZ6683CI works from 4.5V to 18V input voltage range, and provides up to 3A of continuous output current with an output voltage adjustable down to 0.8V.

The AOZ6683CI comes in an ultra thin TSOT23-6L package and is rated from -40°C to +125°C junction temperature range.

Features

- 4.5V to 18V operating input voltage range
- Synchronous Buck: 110mΩ internal high-side switch and 55mΩ internal low-side switch
- Up to 95% efficiency
- Pulse energy mode for high light load efficiency (Vin=12V, Vo=5V, 89% @10mA)
- Output voltage adjustable to 0.8V
- 3A continuous output current
- 750kHz PWM operation
- Internal compensation
- Internal Soft Start
- Cycle-by-cycle current limit
- Pre-bias start-up
- Short-circuit protection
- Thermal shutdown
- Ultra-thin TSOT23-6L package

Applications

- General Point of Load
- LCD TV
- Cable modems and Gateway



Typical Application

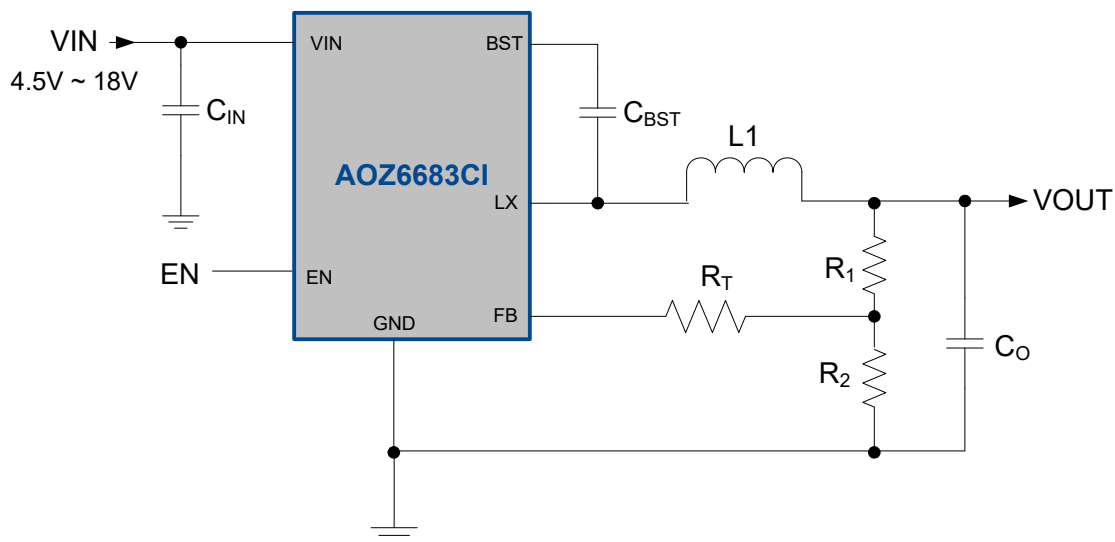

Figure 1. 3A Synchronous Buck Regulator

Ordering Information

Part Number	Ambient Temperature Range	Package	Environmental
AOZ6683CI	-40°C to +125°C	TSOT23-6L	RoHS



AOS Green Products use reduced levels of Halogens, and are also RoHS compliant. Please visit www.aosmd.com/media/AOSGreenPolicy.pdf for additional information.

Pin Configuration

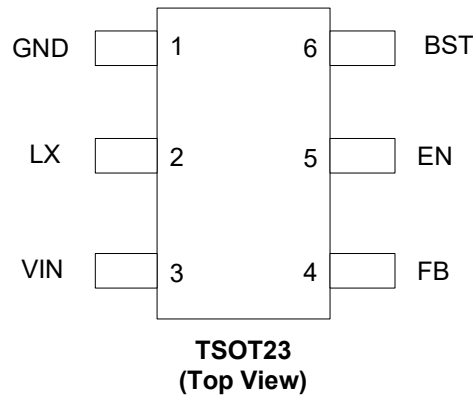

Pin Description

Pin Number	Pin Name	Pin Function
1	GND	System ground.
2	LX	Switching node connects to main inductor terminal.
3	VIN	Supply voltage input. When VIN rises above the UVLO threshold and EN is logic high, the device will start up.
4	FB	Feedback input. The FB pin is used to set the output voltage through a resistor voltage divider between the Output and GND.
5	EN	Enable input. Pull EN to logic high will enable the device. Pull EN to logic low will disable the device. EN pin must be connected to VIN if no Enable control is required.
6	BST	Bootstrap input. Connect a capacitor to LX (Pin 2). Typical value is 0.1uF.

Absolute Maximum Ratings

Exceeding the Absolute Maximum Ratings may damage the device.

Parameter	Rating
Supply Voltage (V_{IN})	-0.3V to 20V
High Voltage Input (EN)	-0.3V to 20V
Switching Node DC (LX to GND)	-0.3V to $V_{IN}+0.3V$
Switching Node Transient (20ns) (LX to GND)	-5V to 22V
Low Voltage Input (FB)	-0.3V to 6V
Bootstrap Voltage (BST to LX)	6V
Junction Temperature (T_J)	150°C
Storage Temperature (T_S)	-65°C to 150°C
ESD Rating ⁽¹⁾	2.0kV

Note:

1. Devices are inherently ESD sensitive, handling precautions are required. Human body model rating: 1.5kΩ in series with 100pF.

Electrical Characteristics

$T_A = 25^\circ\text{C}$, $V_{IN} = V_{EN} = 12V$, $V_{OUT} = 3.3V$, unless otherwise specified. Specifications in **Bold** indicate an ambient temperature range of -40°C to $+85^\circ\text{C}$. These specifications are guaranteed by design.

Symbol	Parameter	Conditions	Min.	Typ.	Max	Units
V_{IN}	Supply Voltage	$-40^\circ\text{C} < T_J < 125^\circ\text{C}$	4.5		18	V
V_{UVLO}	Input Under-Voltage Lockout Threshold	V_{IN} rising V_{IN} falling	3.2	4.1 3.7	4.3	V V
I_{IN}	Supply Current (Quiescent)	$I_{OUT} = 0V$, $V_{FB} = 1.2V$, $EN = 5V$		200	290	μA
I_{OFF}	Shutdown Supply Current	$EN = 0V$, $-40^\circ\text{C} < T_J < 125^\circ\text{C}$		0.1	1	μA
V_{FB}	Feedback Voltage		0.784	0.8	0.816	V
I_{FB}	Feedback Input Current	$FB = 0.8V$			200	nA
R_O	Load Regulation	$500\text{mA} < I_{OUT} < 2A$		0.5		%
S_V	Line Regulation	$4.5V < V_{IN} < 18V$		1		%
I_{FB}	Feedback Voltage Input Current				200	nA
V_{EN}	EN Input Threshold	Off threshold $-40^\circ\text{C} < T_J < 125^\circ\text{C}$			0.6	V
		On threshold $-40^\circ\text{C} < T_J < 125^\circ\text{C}$	2			V
V_{EN_HYS}	Enable Hysteresis			300		mV
I_{EN}	Enable Input Current	$EN=5V$		3	6	μA
t_{SS}	Soft Start Time			2.8		ms
Modulator						
f_O	Frequency	$I_{OUT} > 500\text{mA}$		750		kHz
D_{MAX}	Maximum Duty Cycle			80		%
T_{MIN}	Controllable Minimum On-Time ⁽²⁾			60		ns
D_{MIN}	Controllable Minimum Duty Cycle ⁽²⁾				8	%
GM	Error amplifier GM			400		μA/V

Maximum Operating Ratings

The device is not guaranteed to operate beyond the Maximum Operating ratings.

Supply Voltage (V_{IN})	4.5V to 18V
Output Voltage Range	0.8V to 6V
Junction Temperature (T_J)	-40°C to $+125^\circ\text{C}$
Package Thermal Resistance TSOT23-6L (θ_{JA})	90°C/W

Electrical Characteristics

$T_A = 25^\circ\text{C}$, $V_{IN} = V_{EN} = 12\text{V}$, $V_{OUT} = 3.3\text{V}$, unless otherwise specified. Specifications in **Bold** indicate an ambient temperature range of -40°C to $+85^\circ\text{C}$. These specifications are guaranteed by design.

Symbol	Parameter	Conditions	Min.	Typ.	Max	Units
Protection						
I_{LIM}	Output Current Limit		3.1			A
T_{OTP}	Over Temperature Shutdown Limit	T_J rising T_J falling		150 100		$^\circ\text{C}$ $^\circ\text{C}$
V_{OVP}	Output Over-Voltage Protection Threshold	With respect to FB = 0.8V		125		%
V_{OVP_REC}	Output Over-Voltage Protection Recovery Threshold	With respect to FB = 0.8V		110		%
Output Stage						
R_{HS}	High-Side Switch On-Resistance	BST - LX = 5V		110		m Ω
R_{LS}	Low-Side Switch On-Resistance			55		m Ω

Note:

- Guaranteed by design and not production tested.

Functional Block Diagram

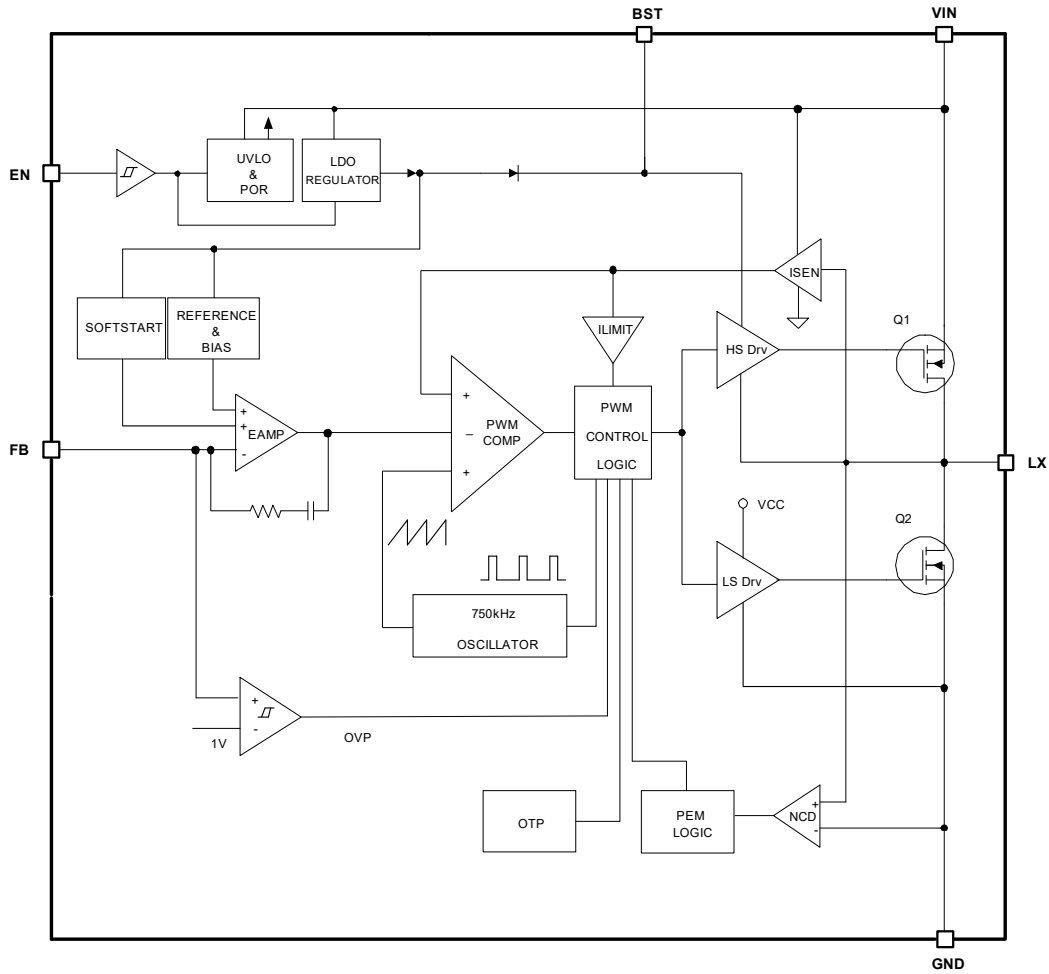

Typical Characteristics (continued)

$T_A = 25^\circ\text{C}$, $V_{IN} = V_{EN} = 12\text{V}$, $V_{OUT} = 3.3\text{V}$, unless otherwise specified.

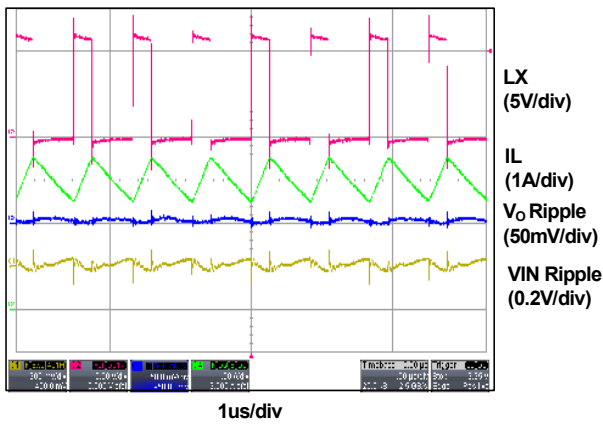

Figure 2. PWM Mode Operation

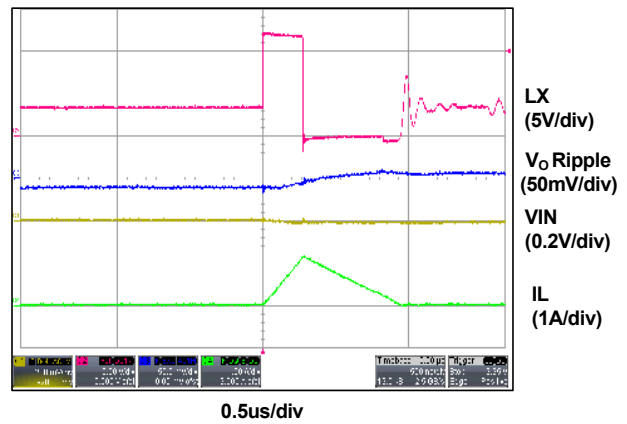

Figure 3. PEM Mode Operation

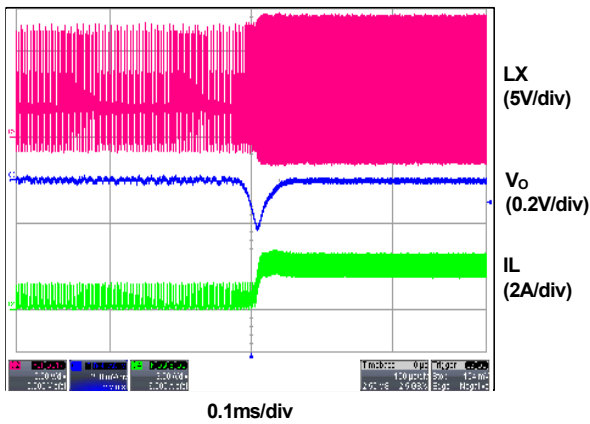

Figure 4. PEM to PWM Mode Change

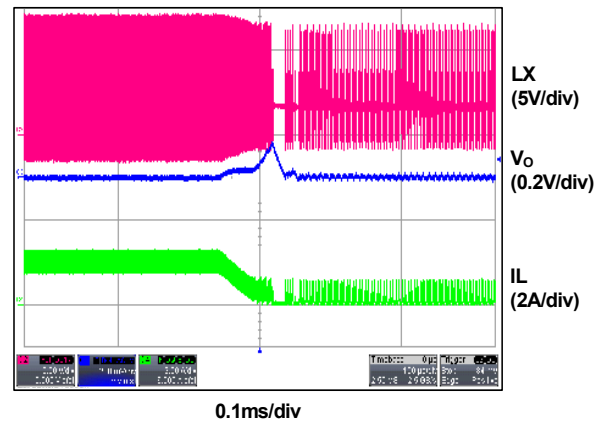

Figure 5. PWM to PEM Mode Change

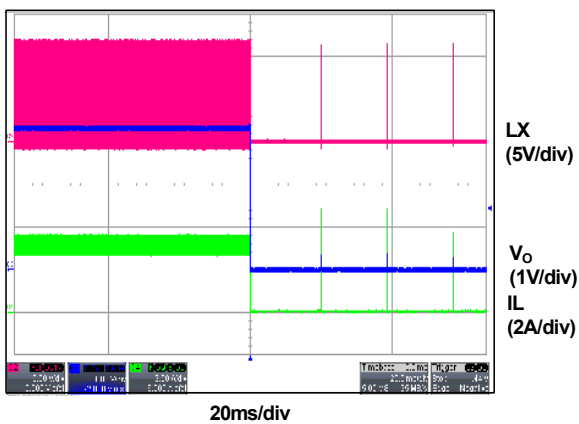

Figure 6. Output Short Protection

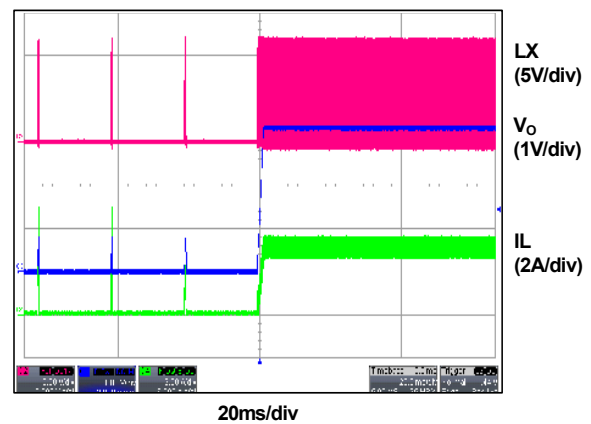

Figure 7. Short Protection Recovery

Typical Characteristics

$T_A = 25^\circ\text{C}$, $V_{IN} = V_{EN} = 12\text{V}$, $V_{OUT} = 3.3\text{V}$, unless otherwise specified.

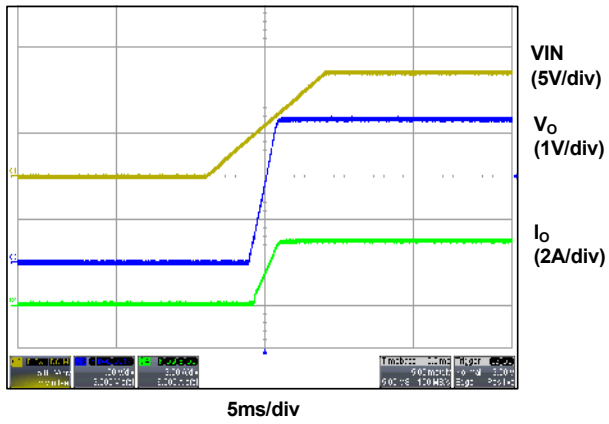

Figure 8. Start up to Full Load

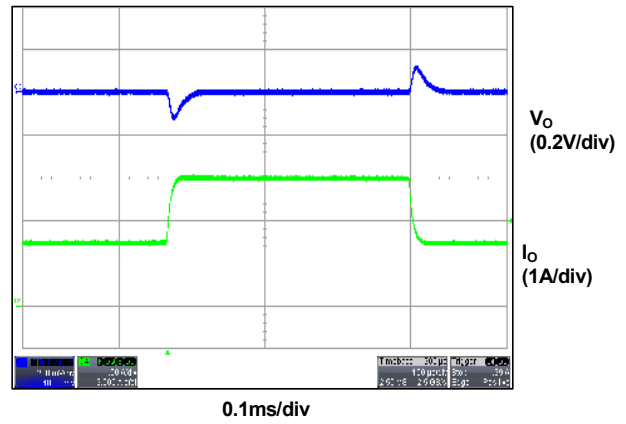

Figure 9. 50% to 100% Load Transient

Efficiency and Derating Curves

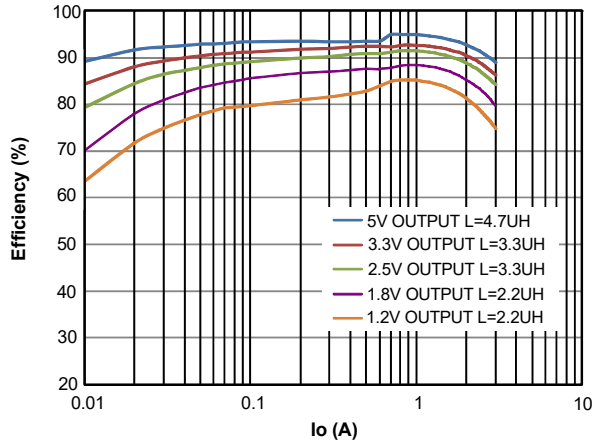

Figure 10. Efficiency vs Output Current. VIN=12V

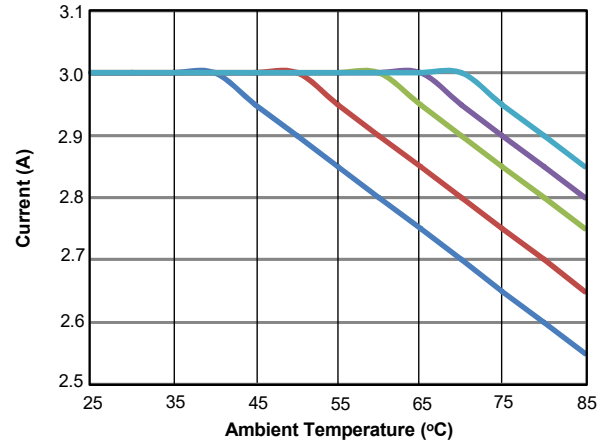

Figure 11. Thermal Derating Curve with 12VIN

Detailed Description

AOZ6683CI is a current-mode step down regulator with integrated high-side and low-side power switches. It operates from 4.5V to 18V input voltage range and supplies up to 3A of continuous load current. Functional features such as Enable control, Power-On Reset (POR), input Under-Voltage LockOut (UVLO), output Over-Voltage Protection (OVP), internal soft-start, and Over-Temperature protection (OTP) shut down are built in. AOZ6683CI is available in compact TSOT23-6L package.

Enable and Soft Start

AOZ6683CI has internal soft start to limit the in-rush current and ensure the output voltage ramps up smoothly to regulation voltage during start up. A soft start process begins when the input voltage VIN rises to 4.1V and enable voltage EN is higher than 2V. The soft start time is pre-programmed to 2.8ms typical.

The EN pin of the AOZ6683CI is active high. Do not leave it open or connect to VIN if enable control signal is not available. The voltage on EN pin must be above 2V to enable and below 0.6V to disable AOZ6683CI.

Light Load and PWM Operation

Under low output current condition, AOZ6683CI will operate in pulse energy mode to achieve high efficiency. In pulse energy mode, the PWM will not turn off until the on time get a fixed time which is defined by Input Voltage (VIN), Output Voltage (Vout), and Switching Frequency.

Steady-State Operation

Under normal to heavy load steady-state condition, AOZ6683CI operates in fixed frequency and Continuous-Conduction Mode (PWM).

AOZ6683CI integrates internal high-side and low-side power MOSFET. Inductor current is sensed through the current being conducted by the power MOSFET. Output voltage is determined by the external voltage divider between Vout, FB, and GND. The difference of the FB voltage and internal reference is amplified by the transconductance error amplifier. The error voltage is compared against the current signal (sum of inductor current signal and input and output modulated voltage ramp compensation signal) at PWM comparator stage. If the current signal is less than the error voltage, the internal high-side switch is on. The inductor current flows from the input through the inductor to the output. When the current signal exceeds the error voltage, the high-side switch is off. The inductor current is freewheeling through the internal low-side switch to output. The internal adaptive MOSFET driver guarantees no turn on overlap between high-side and low-side switch.

Comparing with regulators using freewheeling Schottky diode, AOZ6683CI uses freewheeling MOSFET to realize synchronous rectification. This greatly improves the converter efficiency and reduces power loss in the low-side switch.

AOZ6683CI uses a N-channel MOSFET as the high-side switch. Since the MOSFET requires a gate voltage higher than the input voltage to turn it on, a boost capacitor is needed between BST (Pin 6) and LX (Pin 2) to drive the MOSFET gate. The boost capacitor charge is being replenished when LX is low.

Output Voltage Programming

Output voltage can be set by feeding back the output to the FB pin through a resistor divider network as shown in Figure 1. The T-type resistor divider network includes R1, R2 and RT. Design starts by selecting a fixed R2 value and then calculates the required R1 using the equation below. RT can be used to adjust the feedback loop gain with internal compensation.

$$V_{OUT} = 0.8 \times \left(1 + \frac{R_1}{R_2} \right)$$

Some standard value of R1, R2 and most used output voltage values are listed in Table 1.

VO (V)	R1 (kΩ)	R2 (kΩ)
0.8	1.0	open
1.2	5.0	10
1.5	10.0	11.5
1.8	12.7	10.2
2.5	21.5	10
3.3	31.1	10
5.0	52.3	10

Table 1. Typical Resistor Divider Values for FB Input

Combination of R1 and R2 should be large enough to avoid drawing excessive current from the output, which will cause power loss.

Protection Features

AOZ6683CI has multiple protection features to prevent system circuit damage under abnormal conditions.

Over Current Protection (OCP)

The cycle by cycle current limit is applied for over current protection.

Power-On Reset (POR)

A power-on reset circuit monitors the VIN voltage. When VIN voltage exceeds 4.1V, the converter will start to operate. When VIN voltage falls below 3.7V, the converter will be shut down.

Thermal Protection

An internal temperature sensor monitors the junction temperature. It shuts down the internal control circuit and high side switch if the junction temperature exceeds 150°C. The regulator will restart automatically under the control of soft-start circuit when the junction temperature decreases to 100°C.

Application Information

The basic AOZ6683CI application circuit is show in Figure 1. Component selection is explained below.

Input Capacitor

The input capacitor must be connected to the VIN (Pin 3) and GND (Pin 1) of AOZ6683CI to maintain steady input voltage and filter out the pulsing input current. The voltage rating of input capacitor must be greater than maximum input voltage plus ripple voltage.

The input ripple voltage can be approximated by equation below:

$$\Delta V_{IN} = \frac{I_{OUT}}{f \times C_{IN}} \times \left(1 - \frac{V_{OUT}}{V_{IN}}\right) \times \frac{V_{OUT}}{V_{IN}}$$

Since the input current is discontinuous in a buck converter, the current stress on the input capacitor is another concern when selecting the capacitor. For a buck circuit, the RMS value of input capacitor current can be calculated by:

$$I_{CIN_RMS} = I_{OUT} \times \sqrt{\frac{V_{OUT}}{V_{IN}} \left(1 - \frac{V_{OUT}}{V_{IN}}\right)}$$

if let m equal the conversion ratio:

$$\frac{V_O}{V_{IN}} = m$$

The relation between the input capacitor RMS current and voltage conversion ratio is calculated and shown in Figure 11 below. It can be seen that when V_{OUT} is half of V_{IN} , C_{IN} is under the worst current stress. The worst current stress on C_{IN} is $0.5 \cdot I_{OUT}$.

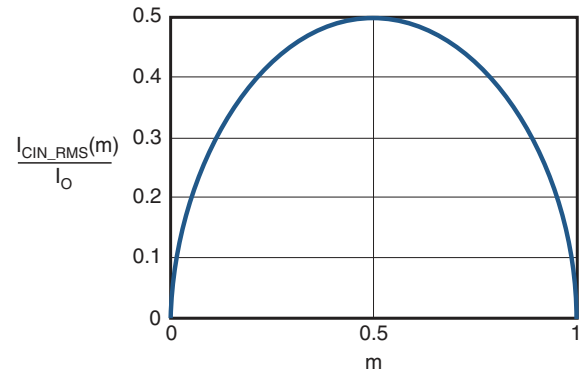

Figure 2. I_{CIN} vs. Voltage Conversion Ratio

For reliable operation and best performance, the input capacitors must have current rating higher than I_{CIN_RMS} at worst operating conditions. Ceramic capacitors are preferred for input capacitors because of their low ESR and high current rating. Depending on the application circuits, other low ESR tantalum capacitor may also be used. When selecting ceramic capacitors, X5R or X7R type dielectric ceramic capacitors should be used for their better temperature and voltage characteristics. Note that the ripple current rating from capacitor manufactures are based on certain amount of life time. Further de-rating may be necessary in practical design.

Inductor

The inductor is used to supply constant current to output when it is driven by a switching voltage. For given input and output voltage, inductance and switching frequency together decide the inductor ripple current as below:

$$\Delta I_L = \frac{V_{OUT}}{f \times L} \times \left(1 - \frac{V_{OUT}}{V_{IN}}\right)$$

The peak inductor current is:

$$I_{Lpeak} = I_{OUT} + \frac{\Delta I_L}{2}$$

High inductance gives low inductor ripple current but requires larger size inductor to avoid saturation. Low ripple current reduces inductor core losses. It also reduces RMS current through inductor and switches, which results in less conduction loss. Usually, peak to peak ripple current on inductor is designed to be 20% to 40% of output current.

When selecting the inductor, make sure it is able to handle the peak current without saturation even at the highest operating temperature.

The inductor takes the highest current in a buck circuit. The conduction loss on inductor needs to be checked for thermal and efficiency requirements.

Surface mount inductors in different shape and styles are available from Coilcraft, Elytone and Murata. Shielded inductors are small and radiate less EMI noise. But they cost more than unshielded inductors. The choice depends on EMI requirement, price and size.

For the current mode control, the minimum inductor 2.2uH is recommended to prevent the current running away in the extreme case.

Output Capacitor

The output capacitor is selected based on the DC output voltage rating, output ripple voltage specification and ripple current rating. The capacitor must have a higher rated voltage specification than the maximum desired output voltage including ripple. De-rating needs to be considered for long term reliability.

Output ripple voltage specification is another important factor for selecting the output capacitor. In a buck converter circuit, output ripple voltage is determined by inductor value, switching frequency, output capacitor value and ESR. It can be calculated by the equation below:

$$\Delta V_O = \Delta I_L \times \left(ESR_{CO} + \frac{1}{8 \times f \times C_O} \right)$$

where C_O is output capacitor value and ESR_{CO} is the Equivalent Series Resistor of output capacitor.

When low ESR ceramic capacitor is used as output capacitor, the impedance of the capacitor at the switching frequency dominates. Output ripple is mainly caused by capacitor value and inductor ripple current. The output ripple voltage calculation can be simplified to:

$$\Delta V_O = \Delta I_L \times \frac{1}{8 \times f \times C_O}$$

If the impedance of ESR at switching frequency dominates, the output ripple voltage is mainly decided by capacitor ESR and inductor ripple current. The output ripple voltage calculation can be further simplified to:

$$\Delta V_O = \Delta I_L \times ESR_{CO}$$

For lower output ripple voltage across the entire operating temperature range, X5R or X7R dielectric type of ceramic, or other low ESR tantalum are recommended to be used as output capacitors.

In a buck converter, output capacitor current is continuous. The RMS current of output capacitor is decided by the peak to peak inductor ripple current. It can be calculated by:

$$I_{CO_RMS} = \frac{\Delta I_L}{\sqrt{12}}$$

Usually, the ripple current rating of the output capacitor is a smaller issue because of the low current stress. When the buck inductor is selected to be very small and inductor ripple current is high, output capacitor could be overstressed.

Thermal Management and Layout Consideration

In the AOZ6683CI buck regulator circuit, high pulsing current flows through two circuit loops. The first loop starts from the input capacitors, to the VIN pin, to the LX pin, to the filter inductor, to the output capacitor and load, and then return to the input capacitor through ground. Current flows in the first loop when the high side switch is on. The second loop starts from inductor, to the output capacitors and load, to the low side switch. Current flows in the second loop when the low side switch is on.

In PCB layout, minimizing the two loops area reduces the noise of this circuit and improves efficiency. A ground plane is strongly recommended to connect input capacitor, output capacitor, and GND pin of the AOZ6683CI.

The major power dissipating components in this buck converter application are AOZ6683CI and the output inductor. The total power dissipation of converter circuit can be measured by input power minus output power.

$$P_{total_loss} = V_{IN} \times I_{IN} - V_{OUT} \times I_{OUT}$$

The power dissipation of inductor can be approximately calculated by output current and DCR of inductor.

$$P_{inductor_loss} = I_O^2 \times R_{inductor} \times 1.1$$

The actual junction temperature can be calculated with power dissipation in the AOZ6683CI and thermal impedance from junction to ambient.

$$T_{junction} = (P_{total_loss} - P_{inductor_loss}) \times \Theta_{JA}$$

The maximum junction temperature of AOZ6683CI is 150°C, which limits the maximum load current capability.

The thermal performance of the AOZ6683CI is strongly affected by the PCB layout. Extra care should be taken by users during design process to ensure that the IC will operate under the recommended environmental conditions.

The AOZ6683CI is TSOT23-6L package. Several layout tips are listed below for the best electric and thermal performance.

1. Do not use thermal relief connection to the VIN and the GND pin. Maximize copper area to the GND pin and the VIN pin to help thermal dissipation.
2. Input capacitor should be connected to the VIN pin and the GND pin as close as possible.
3. Make the current trace from LX pin to L to Co to the GND as short as possible.
4. Pour copper plane on all unused board area and connect it to stable DC nodes, like VIN, GND or VOUT
5. Place the feedback resistors as close to the chip as possible
6. Keep sensitive signal trace away from the LX pin

Package Dimensions, TSOT23-6L

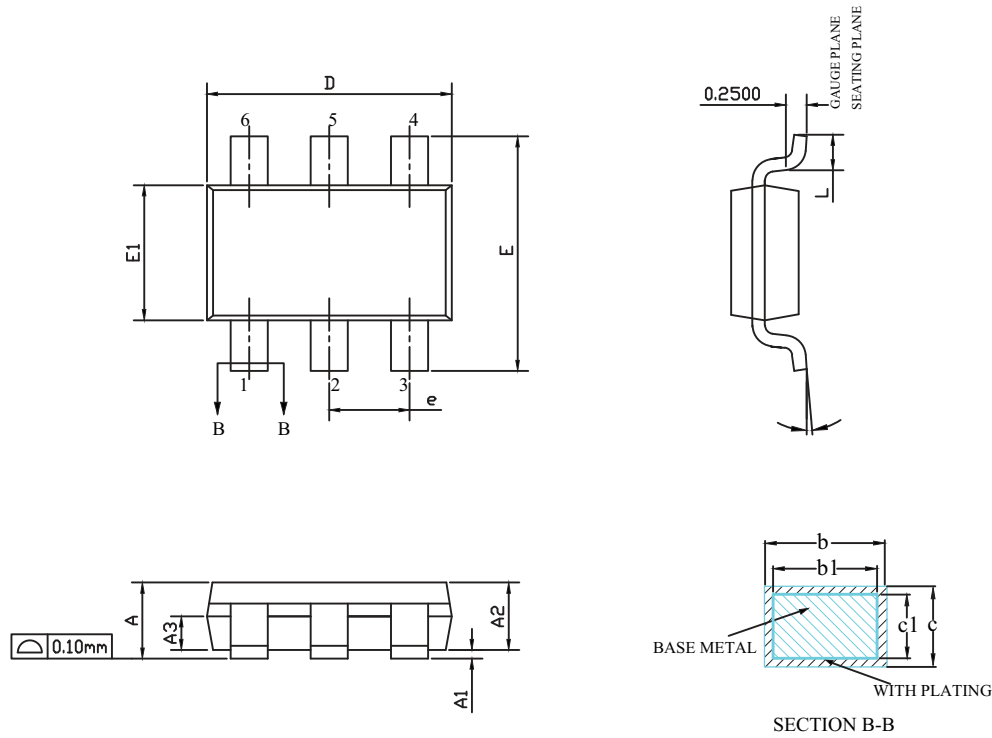

RECOMMENDED LAND PATTERN

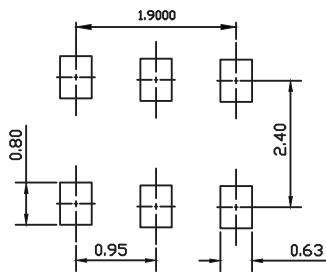

UNIT: mm

SYMBOLS	DIMENSIONS IN MILLIMETERS			DIMENSIONS IN INCHES		
	MIN	NOM	MAX	MIN	NOM	MAX
A	---	---	0.95	----	----	0.037
A1	0.00	---	0.10	0.000	----	0.004
A2	0.75	0.80	0.85	0.030	0.031	0.033
A3	0.35	0.40	0.45	0.014	0.016	0.018
b	0.30	0.44	0.50	0.012	0.017	0.020
b1	0.30	0.40	0.45	0.012	0.016	0.018
c	0.11	0.16	0.20	0.004	0.006	0.008
c1	0.11	0.13	0.15	0.004	0.005	0.006
D	2.70	2.90	3.10	0.106	0.114	0.122
E	2.60	2.80	3.00	0.102	0.110	0.118
E1	1.50	1.60	1.70	0.059	0.063	0.067
e	0.95 BSC			0.037BSC		
L	0.30	0.40	0.50	0.012	0.016	0.020
	0°	---	8°	0°	----	8°

NOTE

1. PACKAGE BODY SIZES EXCLUDE MOLD FLASH OR GATE BURRS.
MOLD FLASH AT THE NON-LEAD SIDES SHOULD BE LESS THAN 6 MILS EACH.
2. TOLERANCE +/-0.100 mm (4 mil) UNLESS OTHERWISE SPECIFIED.
3. DIMENSION L IS MEASURED IN GAUGE PLANE.
4. CONTROLLING DIMENSION IS MILLIMETER. CONVERTED INCH DIMENSIONS ARE NOT NECESSARILY EXACT.
5. ALL DIMENSIONS ARE IN MILLIMETERS.

Tape and Reel Dimensions, TSOT23-6L

TSOT23 6L Carrier Tape

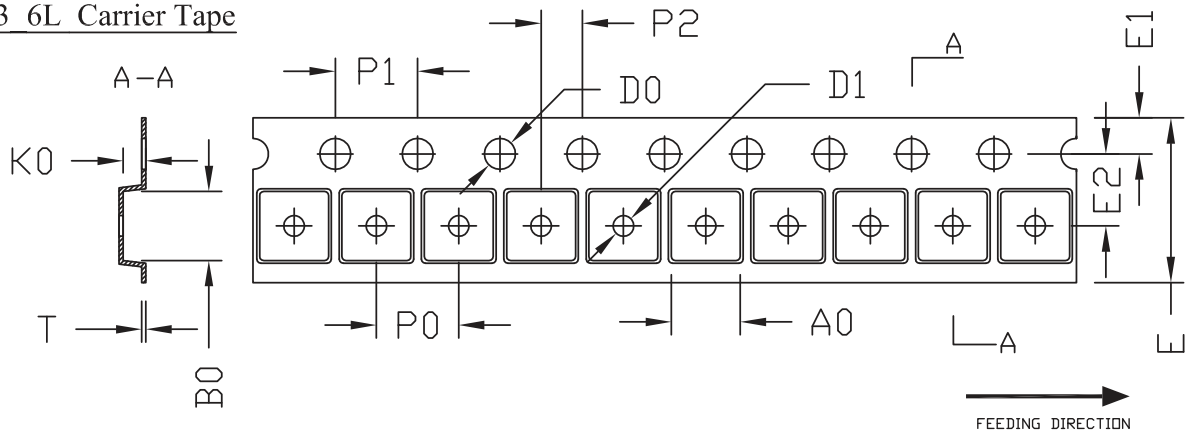

UNIT: MM

PACKAGE	A0	B0	K0	D0	D1	E	E1	E2	P0	P1	P2	T
TSOT23_6L	3.26 ±0.10	3.30 ±0.10	1.40 ±0.10	1.55 +0.10 -0.08	1.05 ±0.05	8.00 ±0.10	1.75 ±0.10	3.50 ±0.05	4.00 ±0.10	4.00 ±0.10	2.00 ±0.05	0.20 ±0.02

TSOT23 6L REEL

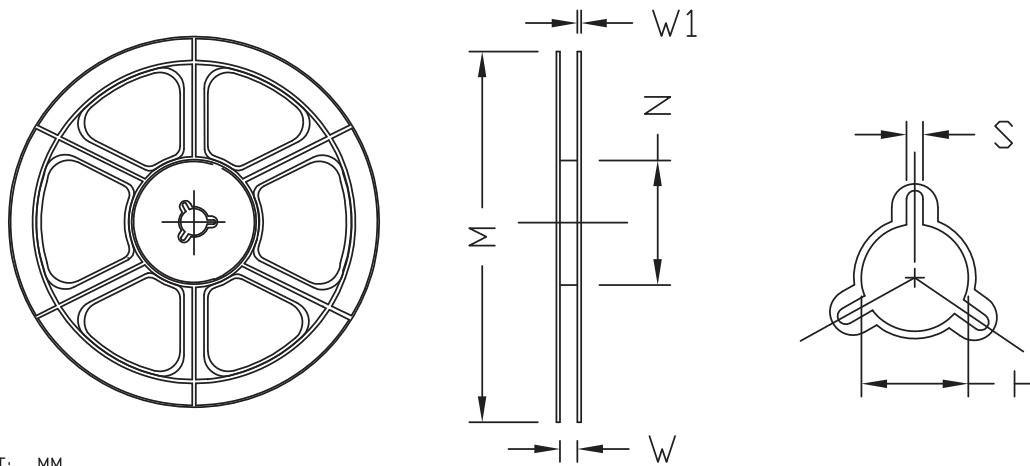

UNIT: MM

TAPE SIZE	REEL SIZE	M	N	W	W1	H	S				
8 mm	∅179	∅179.00 ±1.00	∅54.40 +1.00 -0.16	8.60 +1.00 -0.00	1.40 ±0.30	∅13.00 +0.50 -0.20	2.00 +0.50 -0.00				

TSOT23 6L TAPE

Leader / Trailer
& Orientation

Unit Per Reel:
3000pcs

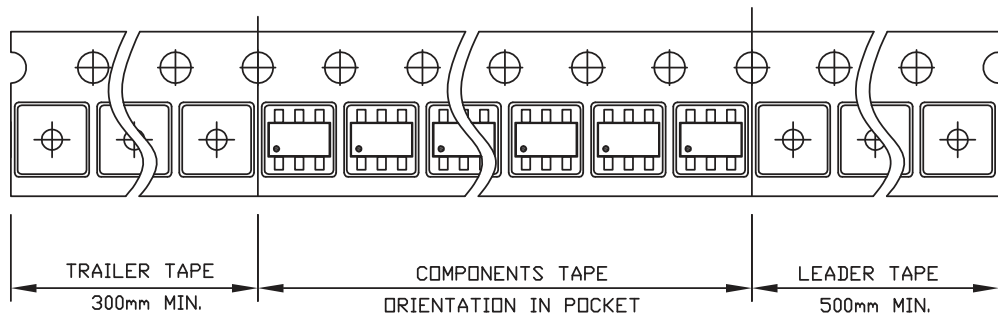

Part Marking

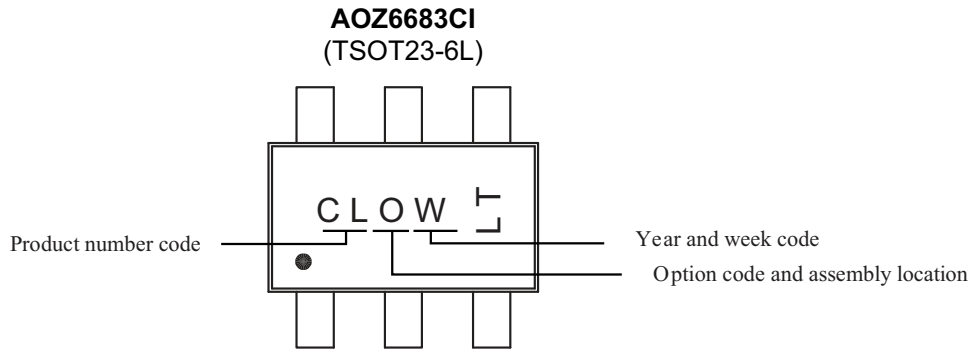

LEGAL DISCLAIMER

Applications or uses as critical components in life support devices or systems are not authorized. AOS does not assume any liability arising out of such applications or uses of its products. AOS reserves the right to make changes to product specifications without notice. It is the responsibility of the customer to evaluate suitability of the product for their intended application. Customer shall comply with applicable legal requirements, including all applicable export control rules, regulations and limitations.

AOS' products are provided subject to AOS' terms and conditions of sale which are set forth at:

http://www.aosmd.com/terms_and_conditions_of_sale

LIFE SUPPORT POLICY

ALPHA AND OMEGA SEMICONDUCTOR PRODUCTS ARE NOT AUTHORIZED FOR USE AS CRITICAL COMPONENTS IN LIFE SUPPORT DEVICES OR SYSTEMS.

As used herein:

- | | |
|---|---|
| <p>1. Life support devices or systems are devices or systems which, (a) are intended for surgical implant into the body or (b) support or sustain life, and (c) whose failure to perform when properly used in accordance with instructions for use provided in the labeling, can be reasonably expected to result in a significant injury of the user.</p> | <p>2. A critical component in any component of a life support, device, or system whose failure to perform can be reasonably expected to cause the failure of the life support device or system, or to affect its safety or effectiveness.</p> |
|---|---|