

## 4.5V to 18V Input, 6-A Synchronous Step-Down Converter with Eco-mode™

Check for Samples: [TPS56628](#)

### FEATURES

- **D-CAP2™ Mode Enables Fast Transient Response**
- **Low Output Ripple and Allows Ceramic Output Capacitor**
- **Wide  $V_{IN}$  Input Voltage Range: 4.5 V to 18 V**
- **Output Voltage Range: 0.76 V to 5.5 V**
- **Highly Efficient Integrated FETs Optimized for Lower Duty Cycle Applications**
  - 36 m $\Omega$  (High Side) and 28 m $\Omega$  (Low Side)
- **High Efficiency, less than 10  $\mu$ A at shutdown**
- **High Initial Bandgap Reference Accuracy**
- **Pre-Biased Soft Start**
- **650-kHz Switching Frequency ( $f_{SW}$ )**
- **Cycle By Cycle Over Current Limit**
- **Auto-Skip Eco-mode™ for High Efficiency at Light Load**
- **Power Good Output**
- **Fixed Soft Start: 1.0 ms**

### APPLICATIONS

- **Wide Range of Applications for Low Voltage System**
  - Digital TV Power Supply
  - High Definition Blu-ray Disc™ Players
  - Networking Home Terminal
  - Digital Set Top Box (STB)

### DESCRIPTION

The TPS56628 is an adaptive on-time D-CAP2™ mode synchronous buck converter. The TPS56628 enables system designers to complete the suite of various end-equipment power bus regulators with a cost effective, low component count, low standby current solution. The main control loop for the TPS56628 uses the D-CAP2™ mode control that provides a fast transient response with no external compensation components. The adaptive on-time control supports seamless transition between PWM mode at higher load conditions and Eco-mode™ operation at light load conditions. Eco-mode™ allows the TPS56628 to maintain high efficiency during lighter load conditions. The TPS56628 also has a proprietary circuit that enables the device to adopt to both low equivalent series resistance (ESR) output capacitors, such as POSCAP or SP-CAP, and ultra-low ESR ceramic capacitors. The device operates from 4.5-V to 18-V  $V_{IN}$  input. The output voltage can be programmed between 0.76 V and 5.5 V. The TPS56628 is available in the 8-pin DDA package, and designed to operate from  $-40^{\circ}\text{C}$  to  $85^{\circ}\text{C}$ .

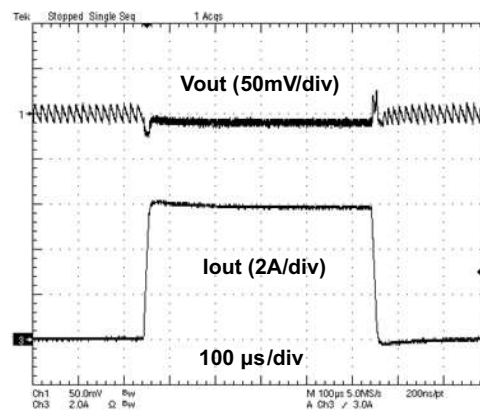
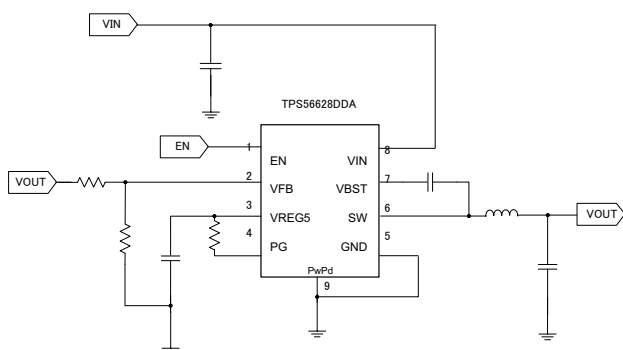

Please be aware that an important notice concerning availability, standard warranty, and use in critical applications of Texas Instruments semiconductor products and disclaimers thereto appears at the end of this data sheet.

D-CAP2, Eco-mode are trademarks of Texas Instruments.  
Blu-ray Disc is a trademark of Blu-ray Disc Association.

# TPS56628

SLVSC94A – OCTOBER 2013 – REVISED DECEMBER 2013

[www.ti.com](http://www.ti.com)



These devices have limited built-in ESD protection. The leads should be shorted together or the device placed in conductive foam during storage or handling to prevent electrostatic damage to the MOS gates.

## ORDERING INFORMATION<sup>(1)(2)(3)</sup>

T <sub>A</sub>	PACKAGE	ORDERABLE PART NUMBER	PIN	TRANSPORT MEDIA
-40°C to 85°C	DDA	TPS56628DDA	8	Tube
		TPS56628DDAR		Tape and Reel

- (1) For the most current package and ordering information, see the Package Option Addendum at the end of this document, or see the TI web site at [www.ti.com](http://www.ti.com).
- (2) Package drawings, thermal data, and symbolization are available at [www.ti.com/packaging](http://www.ti.com/packaging).
- (3) All package options have Cu NIPDAU lead/ball finish.

## ABSOLUTE MAXIMUM RATINGS

over operating free-air temperature range (unless otherwise noted) <sup>(1)</sup>

		VALUE		UNIT
		MIN	MAX	
Input voltage range	VIN, EN	-0.3	20	V
	VBST	-0.3	26	
	VBST (10 ns transient)	-0.3	28	
	VBST (vs SW)	-0.3	6.5	
	VFB, PG	-0.3	6.5	
	SW	-2	20	
	SW (10 ns transient)	-3	22	
Output voltage range	VREG5	-0.3	6.5	V
Voltage from GND to thermal pad, V <sub>diff</sub>		-0.2	0.2	V
Electrostatic discharge	Human Body Model (HBM)		2	kV
	Charged Device Model (CDM)		500	V
Operating junction temperature, T <sub>J</sub>		-40	150	°C
Storage temperature, T <sub>stg</sub>		-55	150	

- (1) Stresses beyond those listed under *absolute maximum ratings* may cause permanent damage to the device. These are stress ratings only, and functional operation of the device at these or any other conditions beyond those indicated under *recommended operating conditions* is not implied. Exposure to absolute-maximum-rated conditions for extended periods may affect device reliability.

## THERMAL INFORMATION

THERMAL METRIC		TPS56628	UNITS
		DDA (8 PINS)	
θ <sub>JA</sub>	Junction-to-ambient thermal resistance	43.5	°C/W
θ <sub>JCtop</sub>	Junction-to-case (top) thermal resistance	49.4	
θ <sub>JB</sub>	Junction-to-board thermal resistance	25.6	
ψ <sub>JT</sub>	Junction-to-top characterization parameter	7.4	
ψ <sub>JB</sub>	Junction-to-board characterization parameter	25.5	
θ <sub>JCbot</sub>	Junction-to-case (bottom) thermal resistance	5.2	

## RECOMMENDED OPERATING CONDITIONS

over operating free-air temperature range, (unless otherwise noted)

			MIN	MAX	UNIT
V <sub>IN</sub>	Supply input voltage range		4.5	18	V
V <sub>I</sub>	Input voltage range	VBST	-0.1	24	V
		VBST (10 ns transient)	-0.1	27	
		VBST(vs SW)	-0.1	6.0	
		PG	-0.1	5.7	
		EN	-0.1	18	
		VFB	-0.1	5.5	
		SW	-1.8	18	
		SW (10 ns transient)	-3	22	
V <sub>O</sub>	Output voltage range	VREG5	-0.1	5.7	V
I <sub>O</sub>	Output Current range	I <sub>VREG5</sub>	0	5	mA
T <sub>A</sub>	Operating free-air temperature		-40	85	°C

## ELECTRICAL CHARACTERISTICS

over operating free-air temperature range, V<sub>IN</sub> = 12 V (unless otherwise noted)

PARAMETER		TEST CONDITIONS	MIN	TYP	MAX	UNIT
<b>SUPPLY CURRENT</b>						
I <sub>VIN</sub>	Operating - non-switching supply current	V <sub>IN</sub> current, T <sub>A</sub> = 25°C, EN = 5 V, V <sub>FB</sub> = 0.8 V		950	1400	μA
I <sub>VINSDN</sub>	Shutdown supply current	V <sub>IN</sub> current, T <sub>A</sub> = 25°C, EN = 0 V		3	10	μA
<b>LOGIC THRESHOLD</b>						
V <sub>EN</sub>	EN high-level input voltage	EN	1.6			V
	EN low-level input voltage	EN			0.6	V
R <sub>EN</sub>	EN pin resistance to GND	V <sub>EN</sub> = 12 V	200	400	800	kΩ
<b>V<sub>FB</sub> VOLTAGE</b>						
V <sub>FBTH</sub>	V <sub>FB</sub> threshold voltage	T <sub>A</sub> = 25°C, V <sub>O</sub> = 1.05 V, I <sub>O</sub> = 10 mA, Eco-mode™ operation		772		mV
		T <sub>A</sub> = 25°C, V <sub>O</sub> = 1.05 V, continuous mode operation	757	765	773	mV
		T <sub>A</sub> = -40 to 85°C, V <sub>O</sub> = 1.05 V, continuous mode operation <sup>(1)</sup>	751		779	mV
I <sub>VFB</sub>	V <sub>FB</sub> input current	V <sub>FB</sub> = 0.8 V, T <sub>A</sub> = 25°C		0	±0.15	μA
<b>V<sub>REG5</sub> OUTPUT</b>						
V <sub>VREG5</sub>	V <sub>REG5</sub> output voltage	T <sub>A</sub> = 25°C, 6 V < V <sub>IN</sub> < 18 V, 0 < I <sub>VREG5</sub> < 5 mA	5.2	5.5	5.7	V
I <sub>VREG5</sub>	Output current	V <sub>IN</sub> = 6 V, V <sub>REG5</sub> = 4.0 V, T <sub>A</sub> = 25°C		20		mA
<b>V<sub>FB</sub> VOLTAGE AND DISCHARGE RESISTANCE</b>						
R <sub>DISCHG</sub>	V <sub>OUT</sub> discharge resistance	EN = 0 V, SW = 0.5 V, T <sub>A</sub> = 25°C		500	800	Ω
<b>MOSFET</b>						
R <sub>DS(on)</sub>	High side switch resistance	25°C, V <sub>BST</sub> - SW = 5.5 V		36		mΩ
	Low side switch resistance	25°C		28		mΩ
<b>CURRENT LIMIT</b>						
I <sub>OCL</sub>	Current limit	L out = 1.5 μH <sup>(1)</sup>	6.6	7.3	8.9	A

(1) Not production tested.

**TPS56628**

SLVSC94A – OCTOBER 2013 – REVISED DECEMBER 2013

[www.ti.com](http://www.ti.com)
**ELECTRICAL CHARACTERISTICS (continued)**

 over operating free-air temperature range,  $V_{IN} = 12\text{ V}$  (unless otherwise noted)

PARAMETER		TEST CONDITIONS	MIN	TYP	MAX	UNIT
<b>THERMAL SHUTDOWN</b>						
$T_{SDN}$	Thermal shutdown threshold	Shutdown temperature <sup>(2)</sup>		165		°C
		Hysteresis <sup>(2)</sup>		35		
<b>ON-TIME TIMER CONTROL</b>						
$t_{ON}$	On time	$V_{IN} = 12\text{ V}$ , $V_O = 1.05\text{ V}$		150		ns
$t_{OFF(MIN)}$	Minimum off time	$T_A = 25^\circ\text{C}$ , $V_{FB} = 0.7\text{ V}$		260	310	ns
<b>SOFT START</b>						
$T_{SS}$	Soft-start time	Internal soft-start time	0.7	1.0	1.3	ms
<b>POWER GOOD</b>						
$V_{THPG}$	PG threshold	VFB rising (Good)	85%	90%	95%	
		VFB falling (Fault)		85%		
IPG	PG sink current	PG = 5 V	2	4		mA
<b>HICCUP AND OVER-VOLTAGE PROTECTION</b>						
$V_{OVP}$	Output OVP threshold	OVP Detect (L > H)		125%		
$V_{HICCUP}$	Output Hiccup threshold	Hiccup detect (H > L)		65%		
$T_{HICCUPDELAY}$	Output Hiccup delay	To hiccup state		250		μs
$T_{HICCUPENDELAY}$	Output Hiccup Enable delay	Relative to soft-start time		x1.7		
<b>UVLO</b>						
UVLO	UVLO threshold	Wake up $V_{REG5}$ voltage	3.45	3.75	4.05	V
		Hysteresis $V_{REG5}$ voltage	0.13	0.32	0.48	

(2) Not production tested.

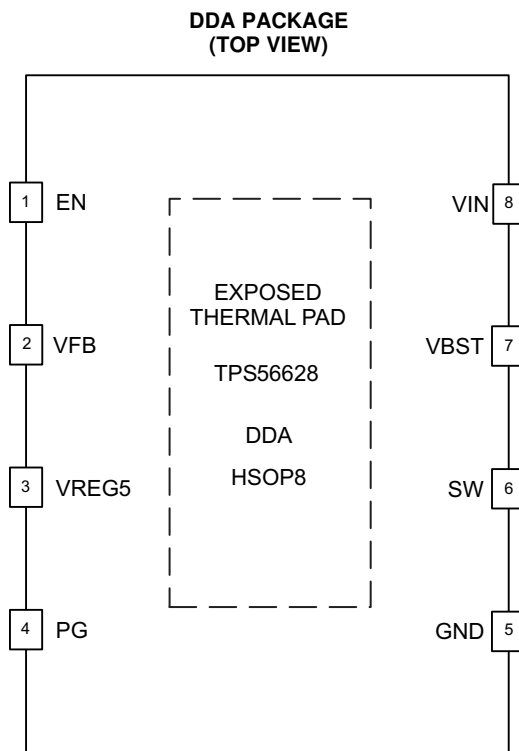
**DEVICE INFORMATION**

**PIN FUNCTIONS**

PIN		DESCRIPTION
NAME	NO.	
EN	1	Enable input control. EN is active high and must be pulled up to enable the device.
VFB	2	Converter feedback input. Connect to output voltage with feedback resistor divider.
VREG5	3	5.5 V power supply output. A capacitor (typical 1 $\mu$ F) should be connected to GND. VREG5 is not active when EN is low.
PG	4	Open drain power good output
GND	5	Ground pin. Power ground return for switching circuit. Connect sensitive VFB returns to GND at a single point.
SW	6	Switch node connection between high-side NFET and low-side NFET.
VBST	7	Supply input for the high-side FET gate drive circuit. Connect 0.1 $\mu$ F capacitor between VBST and SW pins. An internal diode is connected between VREG5 and VBST.
VIN	8	Input voltage supply pin.
Exposed Thermal Pad	Back side	Thermal pad of the package. Must be soldered to achieve appropriate dissipation. Must be connected to GND.

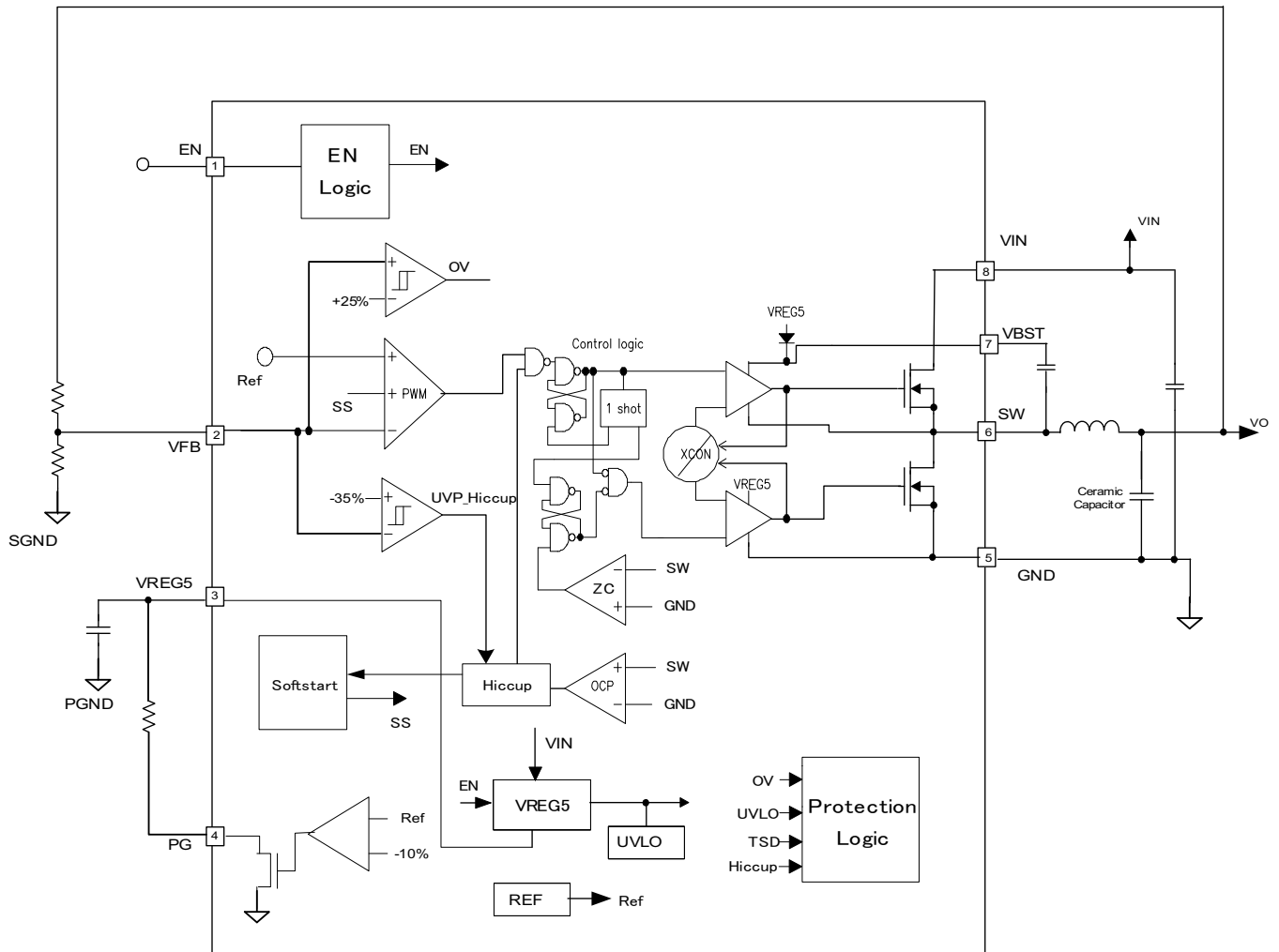
FUNCTIONAL BLOCK DIAGRAM



## OVERVIEW

The TPS56628 is a 6-A synchronous step-down (buck) converter with two integrated N-channel MOSFETs with Auto-Skip mode to improve light load efficiency. It operates using D-CAP2™ mode control. The fast transient response of D-CAP2™ control reduces the output capacitance required to meet a specific level of performance. Proprietary internal circuitry allows the use of low ESR output capacitors including ceramic and special polymer types. The PG output can be used for sequence operation.

## DETAILED DESCRIPTION

### PWM Operation

The main control loop of the TPS56628 is an adaptive on-time pulse width modulation (PWM) controller that supports a proprietary D-CAP2™ mode control. D-CAP2™ mode control combines adaptive on-time control with an internal compensation circuit for pseudo-fixed frequency and low external component count configuration with both low ESR and ceramic output capacitors. It is stable even with virtually no ripple at the output.

At the beginning of each cycle, the high-side MOSFET is turned on. This MOSFET is turned off after internal one shot timer expires. This one shot is set by the converter input voltage, VIN, and the output voltage, VO, to maintain a pseudo-fixed frequency over the input voltage range, hence it is called adaptive on-time control. The one-shot timer is reset and the high-side MOSFET is turned on again when the feedback voltage falls below the reference voltage. An internal ramp is added to reference voltage to simulate output ripple, eliminating the need for ESR induced output ripple from D-CAP2™ mode control.

### PWM Frequency and Adaptive On-Time Control

TPS56628 uses an adaptive on-time control scheme and does not have a dedicated on board oscillator. The TPS56628 runs with a pseudo-constant frequency of 650 kHz by using the input voltage and output voltage to set the on-time one-shot timer. The on-time is inversely proportional to the input voltage and proportional to the output voltage; therefore, when the duty ratio is VOUT/VIN, the frequency is constant.

### Auto-Skip Eco-mode™ Control

The TPS56628 is designed with Auto-Skip Eco-mode™ to increase light load efficiency. As the output current decreases from heavy load condition, the inductor current is also reduced and eventually comes to a point where its rippled valley touches zero level, which is the boundary between continuous conduction and discontinuous conduction modes. The rectifying MOSFET is turned off when its zero inductor current is detected. As the load current further decreases the converters runs in discontinuous conduction mode. The on-time is kept almost the same as it was in the continuous conduction mode so that it takes longer time to discharge the output capacitor with smaller load current to the level of the reference voltage. The transition point to the light load operation IOUT(LL) current can be calculated in [Equation 1](#)

$$I_{OUT(LL)} = \frac{1}{2 \cdot L \cdot f_{sw}} \cdot \frac{(V_{IN} - V_{OUT}) \cdot V_{OUT}}{V_{IN}} \quad (1)$$

### Soft Start and Pre-Biased Soft Start

The TPS56628 has an internal 1.0 ms soft-start. When the EN pin becomes high, internal soft-start function begins ramping up the reference voltage to the PWM comparator.

The TPS56628 contains a unique circuit to prevent current from being pulled from the output during startup if the output is pre-biased. When the soft-start commands a voltage higher than the pre-bias level (internal soft start becomes greater than feedback voltage VFB), the controller slowly activates synchronous rectification by starting the first low side FET gate driver pulses with a narrow on-time. It then increments that on-time on a cycle-by-cycle basis until it coincides with the time dictated by (1-D), where D is the duty cycle of the converter. This scheme prevents the initial sinking of the pre-bias output, and ensure that the out voltage (VO) starts and ramps up smoothly into regulation and the control loop is given time to transition from pre-biased start-up to normal mode operation.

## Power Good

The power-good function is activated after soft start has finished. The power good function becomes active after 1.7 times soft-start time. When the output voltage becomes within -10% of the target value, internal comparators detect power good state and the power good signal becomes high. The power good output, PG is an open drain output. If the feedback voltage goes under 15% of the target value, the power good signal becomes low. R<sub>pg</sub> resistor value, which is connected between PG and VREG5, is required from 25kΩ to 150kΩ.

## Current Protection

The output overcurrent protection (OCP) is implemented using a cycle-by-cycle valley detect control circuit. The switch current is monitored by measuring the low-side FET switch voltage between the SW pin and GND. This voltage is proportional to the switch current. To improve accuracy, the voltage sensing is temperature compensated.

During the on time of the high-side FET switch, the switch current increases at a linear rate determined by V<sub>IN</sub>, V<sub>OUT</sub>, the on-time and the output inductor value. During the on time of the low-side FET switch, this current decreases linearly. The average value of the switch current is the load current I<sub>OUT</sub>. The TPS56628 constantly monitors the low-side FET switch voltage, which is proportional to the switch current, during the low-side on-time. If the measured voltage is above the voltage proportional to the current limit, an internal counter is incremented per each SW cycle and the converter maintains the low-side switch on until the measured voltage is below the voltage corresponding to the current limit at which time the switching cycle is terminated and a new switching cycle begins. In subsequent switching cycles, the on-time is set to a fixed value and the current is monitored in the same manner. If the over current condition exists for 7 consecutive switching cycles, the internal OCL threshold is set to a lower level, reducing the available output current. When a switching cycle occurs where the switch current is not above the lower OCL threshold, the counter is reset and the OCL limit is returned to the higher value.

There are some important considerations for this type of over-current protection. The load current one half of the peak-to-peak inductor current is higher than the over-current threshold also when the current is being limited, the output voltage tends to fall as the demanded load current may be higher than the current available from the converter. This may cause the output voltage to fall. When the VFB voltage becomes lower than 65% of the target voltage, the UVP comparator detects it. After 250 μs detecting the UVP voltage, device will shut down and re-start after approximately 12ms hiccup time

When the over-current condition is removed, the output voltage returns to the regulated value.

## Overvoltage Protection

TPS56628 detects overvoltage conditions by monitoring the feedback voltage (VFB). This function is enabled after approximately 1.7 x times the soft start time. When the feedback voltage becomes higher than 125% of the target voltage, the OVP comparator output goes high and both the high-side MOSFET driver and the low-side MOSFET driver turn off. This function is non-latch operation.

## UVLO Protection

Undervoltage lock out protection (UVLO) monitors the voltage of the VREG5 pin. When the VREG5 voltage is lower than UVLO threshold voltage, the TPS56628 is shut off. This protection is non-latching.

## Thermal Shutdown

TPS56628 monitors the temperature of itself. If the temperature exceeds the threshold value (typically 165°C), the device is shut off. This is non-latch protection.



**TYPICAL CHARACTERISTICS**

V<sub>IN</sub> = 12 V, V<sub>O</sub> = 1.05V, T<sub>A</sub> = 25°C (unless otherwise noted).

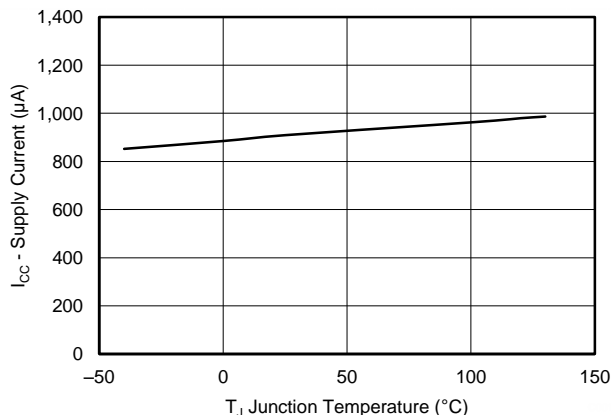

Figure 1. SUPPLY CURRENT vs JUNCTION TEMPERATURE

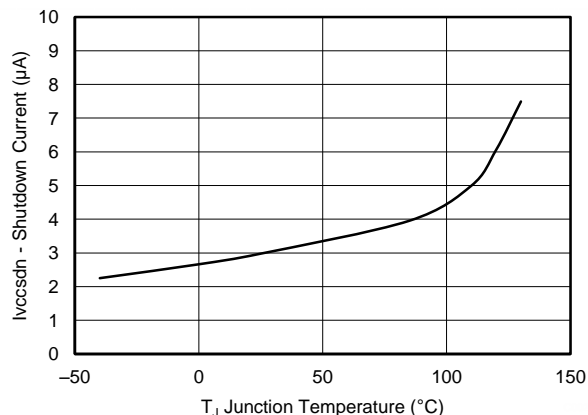

Figure 2. VIN SHUTDOWN CURRENT vs JUNCTION TEMPERATURE

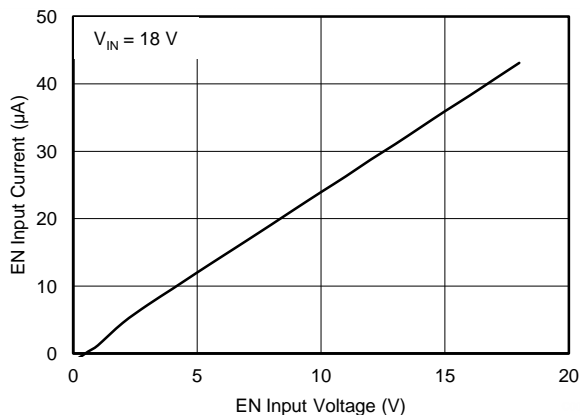

Figure 3. EN CURRENT vs EN VOLTAGE

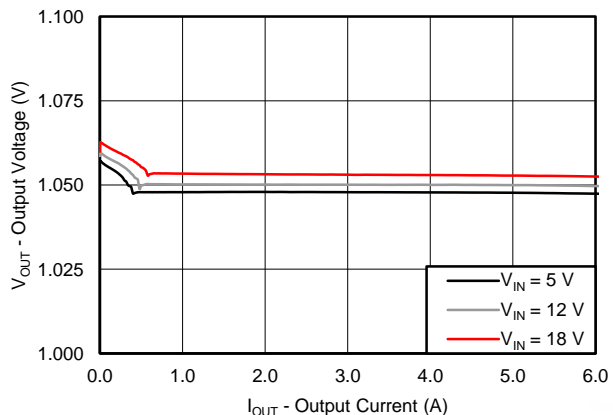

Figure 4. 1.05-V OUTPUT VOLTAGE vs OUTPUT CURRENT

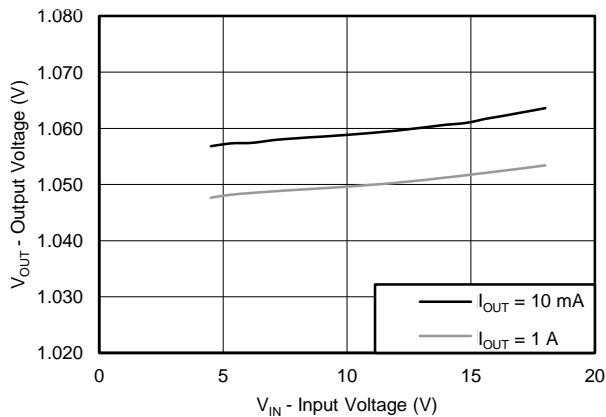

Figure 5. 1.05-V OUTPUT VOLTAGE vs INPUT VOLTAGE

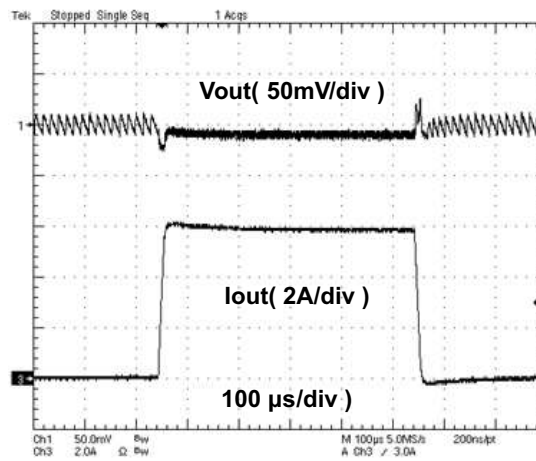

Figure 6. 1.05-V, LOAD TRANSIENT RESPONSE

**TYPICAL CHARACTERISTICS (continued)**

$V_{IN} = 12\text{ V}$ ,  $V_O = 1.05\text{ V}$ ,  $T_A = 25^\circ\text{C}$  (unless otherwise noted).

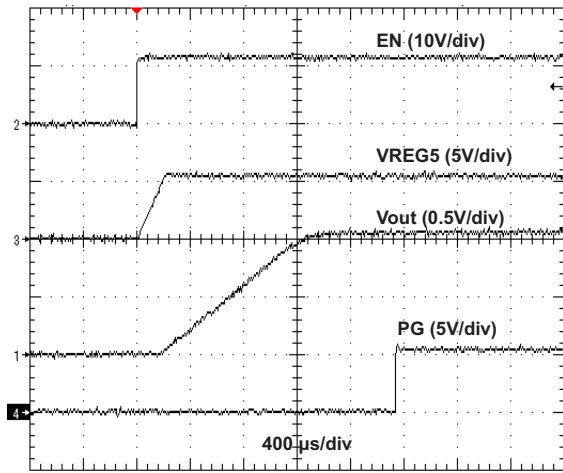

Figure 7. START-UP WAVE FORM

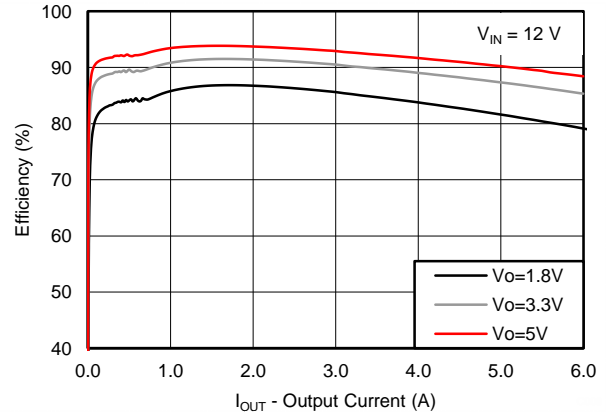

Figure 8. EFFICIENCY vs OUTPUT CURRENT

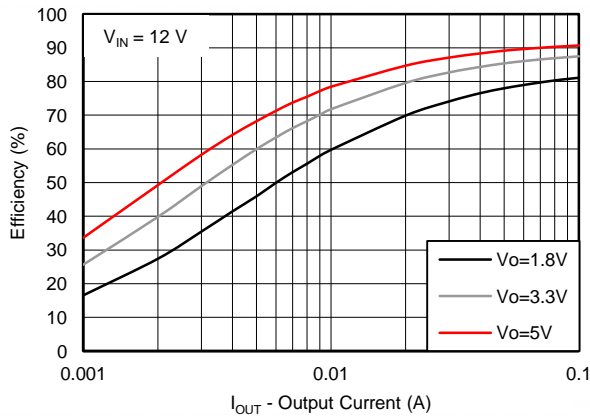

Figure 9. LIGHT LOAD EFFICIENCY vs OUTPUT CURRENT

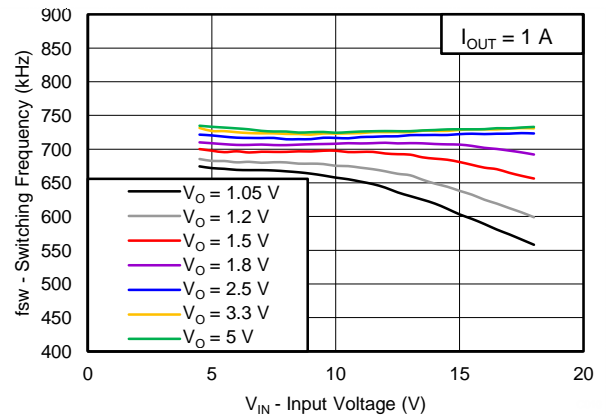

Figure 10. SWITCHING FREQUENCY vs INPUT VOLTAGE

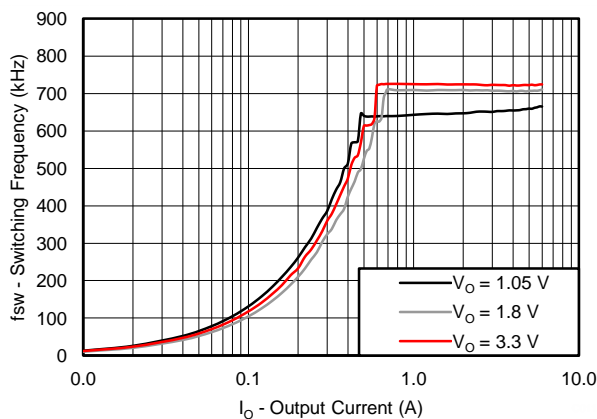

Figure 11. SWITCHING FREQUENCY vs OUTPUT CURRENT

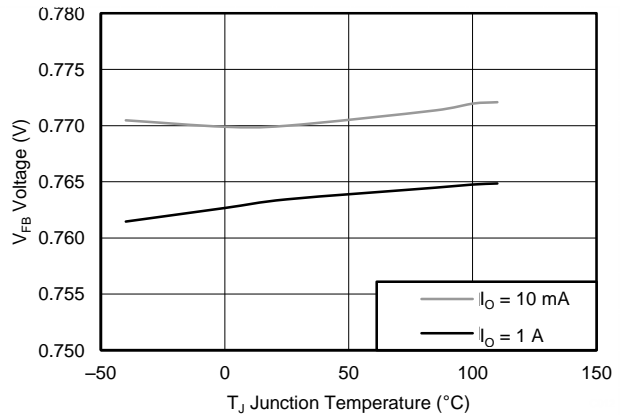
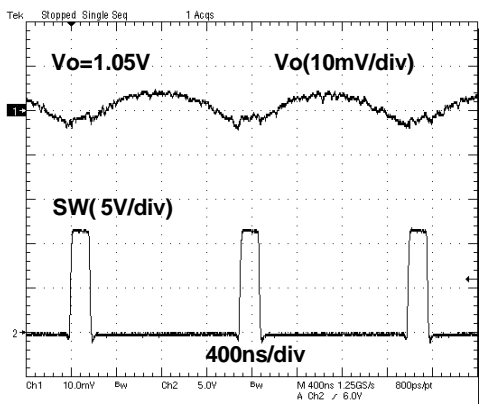

Figure 12. VFB VOLTAGE vs JUNCTION TEMPERATURE

**TYPICAL CHARACTERISTICS (continued)**

VIN = 12 V, VO = 1.05V, TA = 25°C (unless otherwise noted).



**Figure 13. VOLTAGE RIPPLE AT OUTPUT (IO = 6 A)**

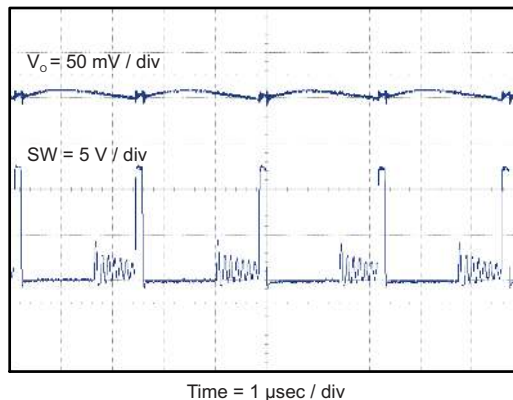

**Figure 14. DCM VOLTAGE RIPPLE AT OUTPUT (IO = 30 mA)**

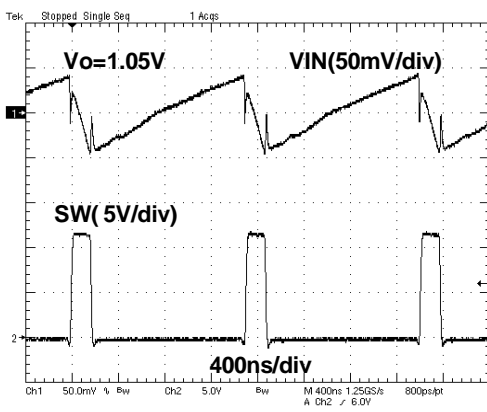

**Figure 15. VOLTAGE RIPPLE AT INPUT (IO = 6 A)**

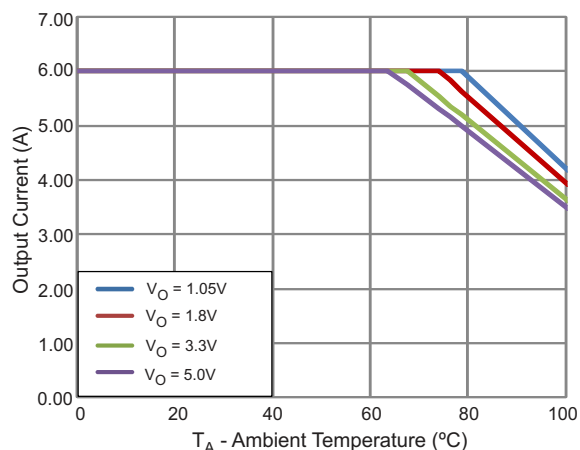

**Figure 16. OUTPUT CURRENT vs AMBIENT TEMPERATURE**

## DESIGN GUIDE

### Step-By-Step Design Procedure

To begin the design process, the user must know a few application parameters:

- Input voltage range
- Output voltage
- Output current
- Output voltage ripple
- Input voltage ripple

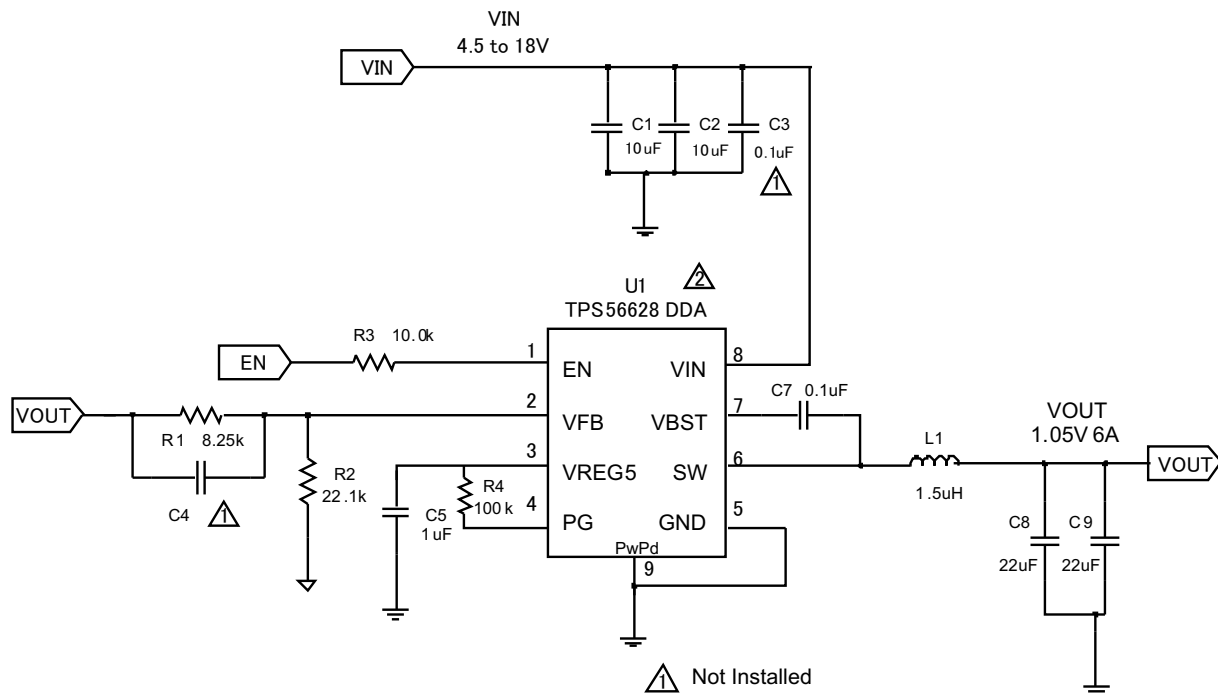

**Figure 17. Shows the Schematic Diagram for This Design Example.**

### Output Voltage Resistors Selection

The output voltage is set with a resistor divider from the output node to the VFB pin. It is recommended to use 1% tolerance or better divider resistors. Start by using Equation 2 to calculate  $V_{OUT}$ .

To improve efficiency at light loads consider using larger value resistors, high resistance is more susceptible to noise, and the voltage errors from the VFB input current are more noticeable.

$$V_{OUT} = 0.765 \times \left( 1 + \frac{R1}{R2} \right) \quad (2)$$

### Output Filter Selection

The output filter used with the TPS56628 is an LC circuit. This LC filter has double pole at:

$$F_P = \frac{1}{2\pi\sqrt{L_{OUT} \times C_{OUT}}} \quad (3)$$

At low frequencies, the overall loop gain is set by the output set-point resistor divider network and the internal gain of the TPS56628. The low frequency phase is 180 degrees. At the output filter pole frequency, the gain rolls off at a –40 dB per decade rate and the phase drops rapidly. D-CAP2™ introduces a high frequency zero that reduces the gain roll off to –20 dB per decade and increases the phase to 90 degrees one decade above the zero frequency. The inductor and capacitor for the output filter must be selected so that the double pole of Equation 3 is located below the high frequency zero but close enough that the phase boost provided by the high frequency zero provides adequate phase margin for a stable circuit. To meet this requirement use the values recommended in Table 1

**Table 1. Recommended Component Values**

Output Voltage (V)	R1 (kΩ)	R2 (kΩ)	C4 (pF) <sup>(1)</sup>			L1 (μH)			C8 + C9 (μF)	
			MIN	TYP	MAX	MIN	TYP	MAX	MIN	MAX
1	6.81	22.1	5	150	220	1.0	1.5	4.7	22	68
1.05	8.25	22.1	5	150	220	1.0	1.5	4.7	22	68
1.2	12.7	22.1	5		100	1.0	1.5	4.7	22	68
1.5	21.5	22.1	5		68	1.0	1.5	4.7	22	68
1.8	30.1	22.1	5		22	1.2	1.5	4.7	22	68
2.5	49.9	22.1	5		22	1.5	2.2	4.7	22	68
3.3	73.2	22.1	2		22	1.8	2.2	4.7	22	68
5	124	22.1	2		22	2.2	3.3	4.7	22	68

(1) Optional

For higher output voltages, additional phase boost can be achieved by adding a feed forward capacitor (C4) in parallel with R1

The inductor peak-to-peak ripple current, peak current and RMS current are calculated using Equation 4, Equation 5 and Equation 6. The inductor saturation current rating must be greater than the calculated peak current and the RMS or heating current rating must be greater than the calculated RMS current.

Use 650 kHz for  $f_{SW}$ . Make sure the chosen inductor is rated for the peak current of Equation 5 and the RMS current of Equation 6.

$$I_{IPP} = \frac{V_{OUT}}{V_{IN(max)}} \times \frac{V_{IN(max)} - V_{OUT}}{L_O \times f_{SW}} \quad (4)$$

$$I_{Ipeak} = I_O + \frac{I_{Ipp}}{2} \quad (5)$$

$$I_{Lo(RMS)} = \sqrt{I_O^2 + \frac{1}{12} I_{IPP}^2} \quad (6)$$

For this design example, the calculated peak current is 6.51 A and the calculated RMS current is 6.01 A. The inductor used is a TDK SPM6530-1R5M100 with a peak current rating of 11.5 A and an RMS current rating of 11 A.

The capacitor value and ESR determines the amount of output voltage ripple. The TPS56628 is intended for use with ceramic or other low ESR capacitors. Recommended values range from 22μF to 68μF. Use Equation 7 to determine the required RMS current rating for the output capacitor.

$$I_{Co(RMS)} = \frac{V_{OUT} \times (V_{IN} - V_{OUT})}{\sqrt{12} \times V_{IN} \times L_O \times f_{SW}} \quad (7)$$

For this design two TDK C3216X5R0J226M 22μF output capacitors are used. The typical ESR is 2 mΩ each. The calculated RMS current is 0.286 A and each output capacitor is rated for 4A.

### Input Capacitor Selection

The TPS56628 requires an input decoupling capacitor and a bulk capacitor is needed depending on the application. A ceramic capacitor over 10  $\mu\text{F}$  is recommended for the decoupling capacitor. An additional 0.1  $\mu\text{F}$  capacitor (C3) from pin 8 to ground is optional to provide additional high frequency filtering. The capacitor voltage rating needs to be greater than the maximum input voltage.

### Bootstrap Capacitor Selection

A 0.1  $\mu\text{F}$ . ceramic capacitor must be connected between the VBST to SW pin for proper operation. It is recommended to use a ceramic capacitor.

### VREG5 Capacitor Selection

A 1- $\mu\text{F}$  ceramic capacitor must be connected between the VREG5 to GND pin for proper operation. It is recommended to use a ceramic capacitor.

## THERMAL INFORMATION

This 8-pin DDA package incorporates an exposed thermal pad that is designed to be directly attached to an external heatsink. The thermal pad must be soldered to the printed circuit board (PCB). After soldering, the PCB can be used as a heatsink. In addition, through the use of thermal vias, the thermal pad can be attached directly to the appropriate copper plane shown in the electrical schematic for the device, or alternatively, can be attached to a special heatsink structure designed into the PCB. This design optimizes the heat transfer from the integrated circuit (IC).

For additional information on the exposed thermal pad and how to use the advantage of its heat dissipating abilities, see the Technical Brief, PowerPAD™ Thermally Enhanced Package, Texas Instruments Literature No. [SLMA002](#) and Application Brief, PowerPAD™ Made Easy, Texas Instruments Literature No. [SLMA004](#).

The exposed thermal pad dimensions for this package are shown in the following illustration.

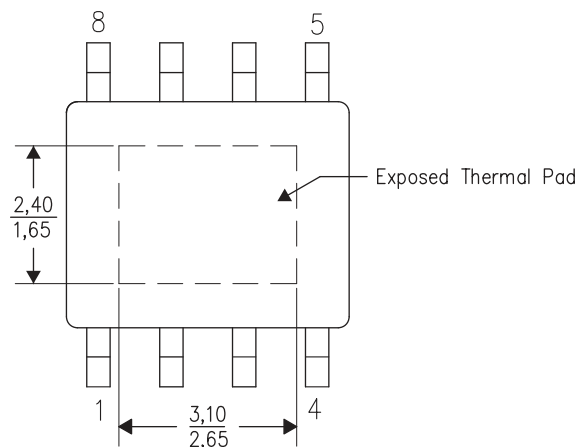

**Figure 18. Thermal Pad Dimensions**

**LAYOUT CONSIDERATIONS**

1. The TPS56628 can supply large load currents up to 6 A, so heat dissipation may be a concern. The top side area of PCB adjacent to the TPS56628 should be filled with ground as much as possible to dissipate heat.
2. The bottom side area directly below the IC should a dedicated ground area. It should be directly connected to the thermal pad of the device using vias as shown. The ground area should be as large as practical. Additional internal layers can be dedicated as ground planes and connected to the vias as well.
3. Keep the input switching current loop as small as possible.
4. Keep the SW node as physically small and short as possible to minimize parasitic capacitance and inductance and to minimize radiated emissions. Kelvin connections should be brought from the output to the feedback pin of the device.
5. Keep analog and non-switching components away from switching components.
6. Make a single point connection from the signal ground to power ground.
7. Do not allow switching current to flow under the device.
8. Keep the pattern lines for VIN, SW, and PGND (POWERGROUND) broad.
9. Exposed pad of device must be connected to PGND with solder.
10. VREG5 capacitor should be placed near the device, and connected PGND.
11. Output capacitor should be connected to a broad pattern of the PGND.
12. Voltage feedback loop should be as short as possible, and preferably with ground shield.
13. Lower resistor of the voltage divider which is connected to the VFB pin should be tied to ANALOG GROUND.
14. Providing sufficient via is preferable for VIN, SW and PGND connection.
15. VFB node should be as short as possible.
16. VIN Capacitor should be placed as near as possible to the device.

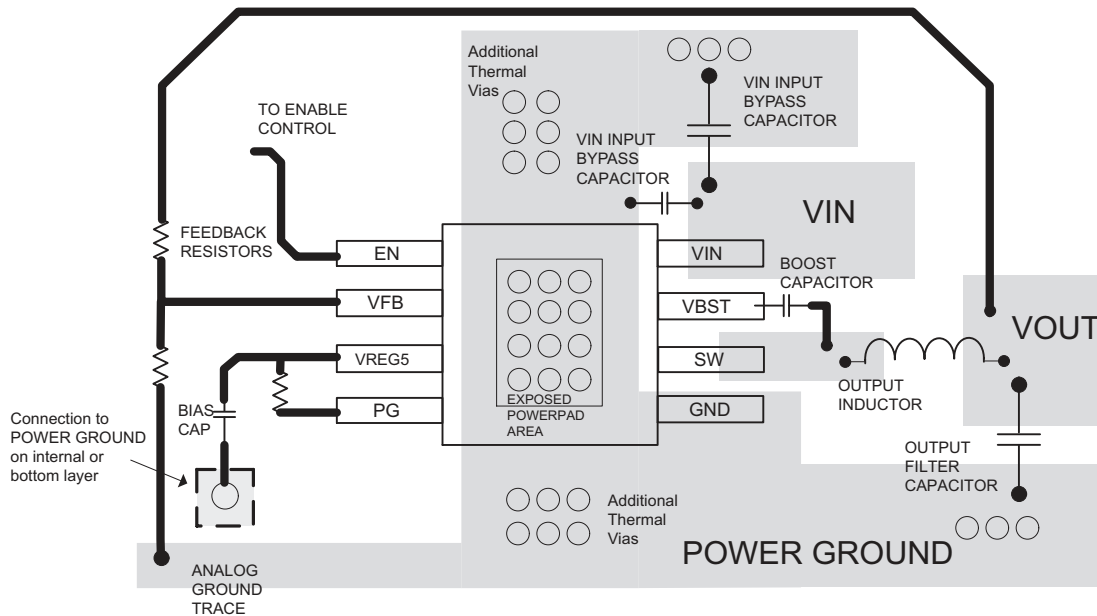

**Figure 19. PCB Layout**

## REVISION HISTORY

NOTE: Page numbers of current version may vary from previous versions.

<b>Changes from Original (October 2013) to Revision A</b>	<b>Page</b>
• Deleted "The device also features an adjustable soft start time." from the Description. ....	1
• Deleted "GND" spec from Output Voltage Range in the Absolute Maximum Ratings table. ....	2
• Deleted "GND" spec from Input Voltage Range in the Recommended Operating Conditions table.. ....	3
• Deleted "T <sub>J</sub> " spec from the Recommended Operating Conditions table. ....	3
• Changed V <sub>THPG</sub> spec for VFB falling (Fault) condition from "65%" to "85%" in Electrical Characteristics table .....	4
• Changed GND pin description from "SS and VFB" to "VFB" in the Pin Functions table. ....	5
• Changed input names from "PGND" to "GND" at the ZC and OCP comparators in the Functional Block Diagram graphic .....	6
• Changed text string from "constant on-time" to "adaptive on-time" in the 1st paragraph of PWM Operation. ....	7
• Changed text string from "detects over and under voltage" to "detects overvoltage" in the Overvoltage Protection section. ....	8
• Added V <sub>O</sub> = 1.05V to Conditions statement for the Typical Characteristics graphs. ....	9
• Changed time scale callout from "100 μs/div" to "400 μs/div" on <a href="#">Figure 7</a> .....	10
• Added V <sub>O</sub> = 1.05V to Conditions statement for the Typical Characteristics graphs. ....	10
• Added V <sub>O</sub> = 1.05V to Conditions statement for the Typical Characteristics graphs. ....	11
• Deleted "-950 mv dc offset" text string from signal trace label; and changed SW label from "10 V/div" to "5 V/div" on <a href="#">Figure 14</a> .....	11
• Changed some itemized notes in the Layout Considerations section for clarification. ....	15



**PACKAGING INFORMATION**

Orderable Device	Status (1)	Package Type	Package Drawing	Pins	Package Qty	Eco Plan (2)	Lead finish/ Ball material (6)	MSL Peak Temp (3)	Op Temp (°C)	Device Marking (4/5)	Samples
TPS56628DDA	ACTIVE	SO PowerPAD	DDA	8	75	RoHS & Green	NIPDAU   NIPDAUAG	Level-2-260C-1 YEAR	-40 to 85	56628	<a href="#">Samples</a>
TPS56628DDAR	ACTIVE	SO PowerPAD	DDA	8	2500	RoHS & Green	NIPDAU   NIPDAUAG	Level-2-260C-1 YEAR	-40 to 85	56628	<a href="#">Samples</a>

(1) The marketing status values are defined as follows:

**ACTIVE:** Product device recommended for new designs.

**LIFEBUY:** TI has announced that the device will be discontinued, and a lifetime-buy period is in effect.

**NRND:** Not recommended for new designs. Device is in production to support existing customers, but TI does not recommend using this part in a new design.

**PREVIEW:** Device has been announced but is not in production. Samples may or may not be available.

**OBSELETE:** TI has discontinued the production of the device.

(2) **RoHS:** TI defines "RoHS" to mean semiconductor products that are compliant with the current EU RoHS requirements for all 10 RoHS substances, including the requirement that RoHS substance do not exceed 0.1% by weight in homogeneous materials. Where designed to be soldered at high temperatures, "RoHS" products are suitable for use in specified lead-free processes. TI may reference these types of products as "Pb-Free".

**RoHS Exempt:** TI defines "RoHS Exempt" to mean products that contain lead but are compliant with EU RoHS pursuant to a specific EU RoHS exemption.

**Green:** TI defines "Green" to mean the content of Chlorine (Cl) and Bromine (Br) based flame retardants meet JS709B low halogen requirements of <=1000ppm threshold. Antimony trioxide based flame retardants must also meet the <=1000ppm threshold requirement.

(3) MSL, Peak Temp. - The Moisture Sensitivity Level rating according to the JEDEC industry standard classifications, and peak solder temperature.

(4) There may be additional marking, which relates to the logo, the lot trace code information, or the environmental category on the device.

(5) Multiple Device Markings will be inside parentheses. Only one Device Marking contained in parentheses and separated by a "~" will appear on a device. If a line is indented then it is a continuation of the previous line and the two combined represent the entire Device Marking for that device.

(6) Lead finish/Ball material - Orderable Devices may have multiple material finish options. Finish options are separated by a vertical ruled line. Lead finish/Ball material values may wrap to two lines if the finish value exceeds the maximum column width.

**Important Information and Disclaimer:**The information provided on this page represents TI's knowledge and belief as of the date that it is provided. TI bases its knowledge and belief on information provided by third parties, and makes no representation or warranty as to the accuracy of such information. Efforts are underway to better integrate information from third parties. TI has taken and continues to take reasonable steps to provide representative and accurate information but may not have conducted destructive testing or chemical analysis on incoming materials and chemicals. TI and TI suppliers consider certain information to be proprietary, and thus CAS numbers and other limited information may not be available for release.

In no event shall TI's liability arising out of such information exceed the total purchase price of the TI part(s) at issue in this document sold by TI to Customer on an annual basis.



**TAPE AND REEL INFORMATION**

**QUADRANT ASSIGNMENTS FOR PIN 1 ORIENTATION IN TAPE**

\*All dimensions are nominal

Device	Package Type	Package Drawing	Pins	SPQ	Reel Diameter (mm)	Reel Width W1 (mm)	A0 (mm)	B0 (mm)	K0 (mm)	P1 (mm)	W (mm)	Pin1 Quadrant
TPS56628DDAR	SO Power PAD	DDA	8	2500	330.0	12.8	6.4	5.2	2.1	8.0	12.0	Q1

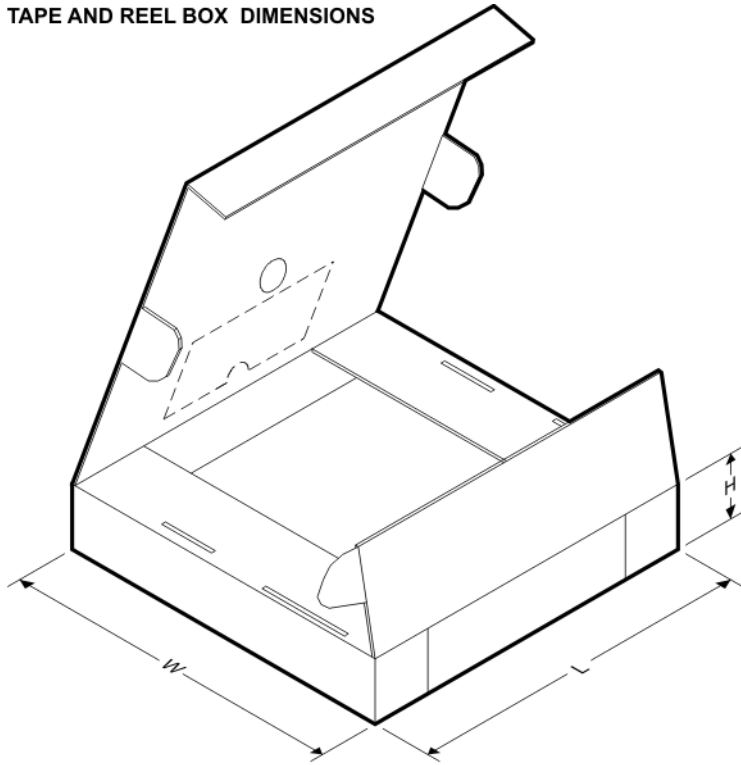
**TAPE AND REEL BOX DIMENSIONS**

\*All dimensions are nominal

Device	Package Type	Package Drawing	Pins	SPQ	Length (mm)	Width (mm)	Height (mm)
TPS56628DDAR	SO PowerPAD	DDA	8	2500	366.0	364.0	50.0

**TUBE**

\*All dimensions are nominal

Device	Package Name	Package Type	Pins	SPQ	L (mm)	W (mm)	T (μm)	B (mm)
TPS56628DDA	DDA	HSOIC	8	75	508	7.77	2540	NA
TPS56628DDA	DDA	HSOIC	8	75	517	7.87	635	4.25

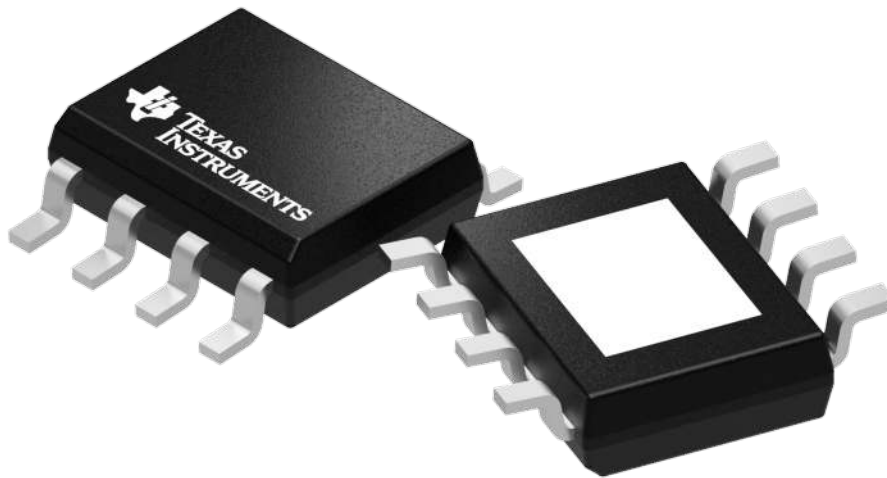

Images above are just a representation of the package family, actual package may vary.  
Refer to the product data sheet for package details.

DDA (R-PDSO-G8)

PowerPAD™ PLASTIC SMALL-OUTLINE

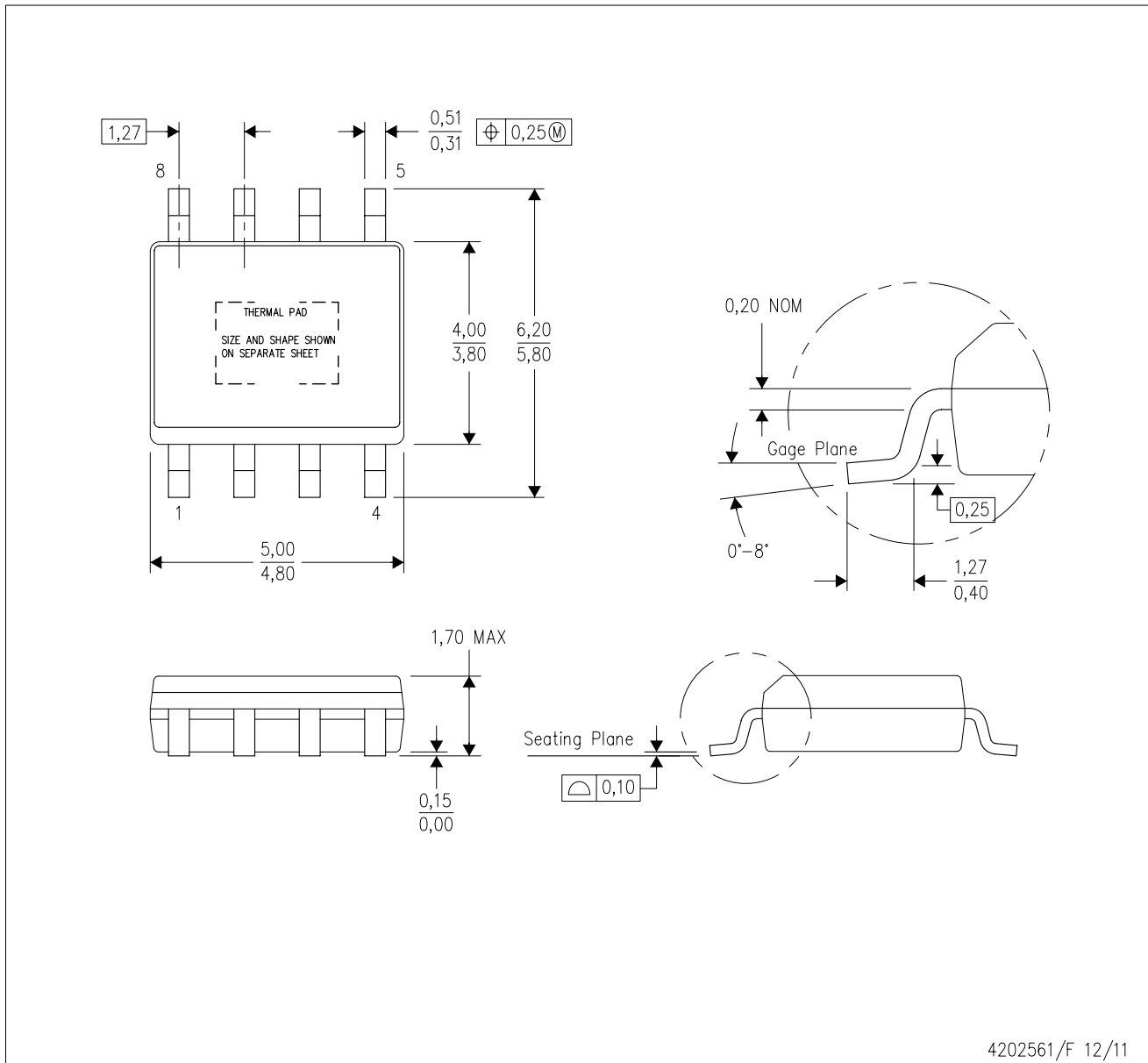

4202561/F 12/11

- NOTES:
- A. All linear dimensions are in millimeters. Dimensioning and tolerancing per ASME Y14.5-1994.
  - B. This drawing is subject to change without notice.
  - C. Body dimensions do not include mold flash or protrusion not to exceed 0,15.
  - D. This package is designed to be soldered to a thermal pad on the board. Refer to Technical Brief, PowerPad Thermally Enhanced Package, Texas Instruments Literature No. SLMA002 for information regarding recommended board layout. This document is available at [www.ti.com](http://www.ti.com) <<http://www.ti.com>>.
  - E. See the additional figure in the Product Data Sheet for details regarding the exposed thermal pad features and dimensions.
  - F. This package complies to JEDEC MS-012 variation BA

PowerPAD is a trademark of Texas Instruments.

DDA (R-PDSO-G8)

PowerPAD™ PLASTIC SMALL OUTLINE

## THERMAL INFORMATION

This PowerPAD™ package incorporates an exposed thermal pad that is designed to be attached to a printed circuit board (PCB). The thermal pad must be soldered directly to the PCB. After soldering, the PCB can be used as a heatsink. In addition, through the use of thermal vias, the thermal pad can be attached directly to the appropriate copper plane shown in the electrical schematic for the device, or alternatively, can be attached to a special heatsink structure designed into the PCB. This design optimizes the heat transfer from the integrated circuit (IC).

For additional information on the PowerPAD package and how to take advantage of its heat dissipating abilities, refer to Technical Brief, PowerPAD Thermally Enhanced Package, Texas Instruments Literature No. SLMA002 and Application Brief, PowerPAD Made Easy, Texas Instruments Literature No. SLMA004. Both documents are available at [www.ti.com](http://www.ti.com).

The exposed thermal pad dimensions for this package are shown in the following illustration.

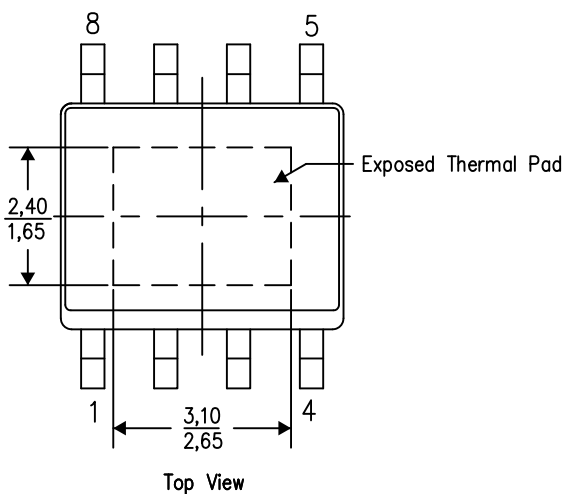

Exposed Thermal Pad Dimensions

4206322-6/L 05/12

NOTE: A. All linear dimensions are in millimeters

PowerPAD is a trademark of Texas Instruments



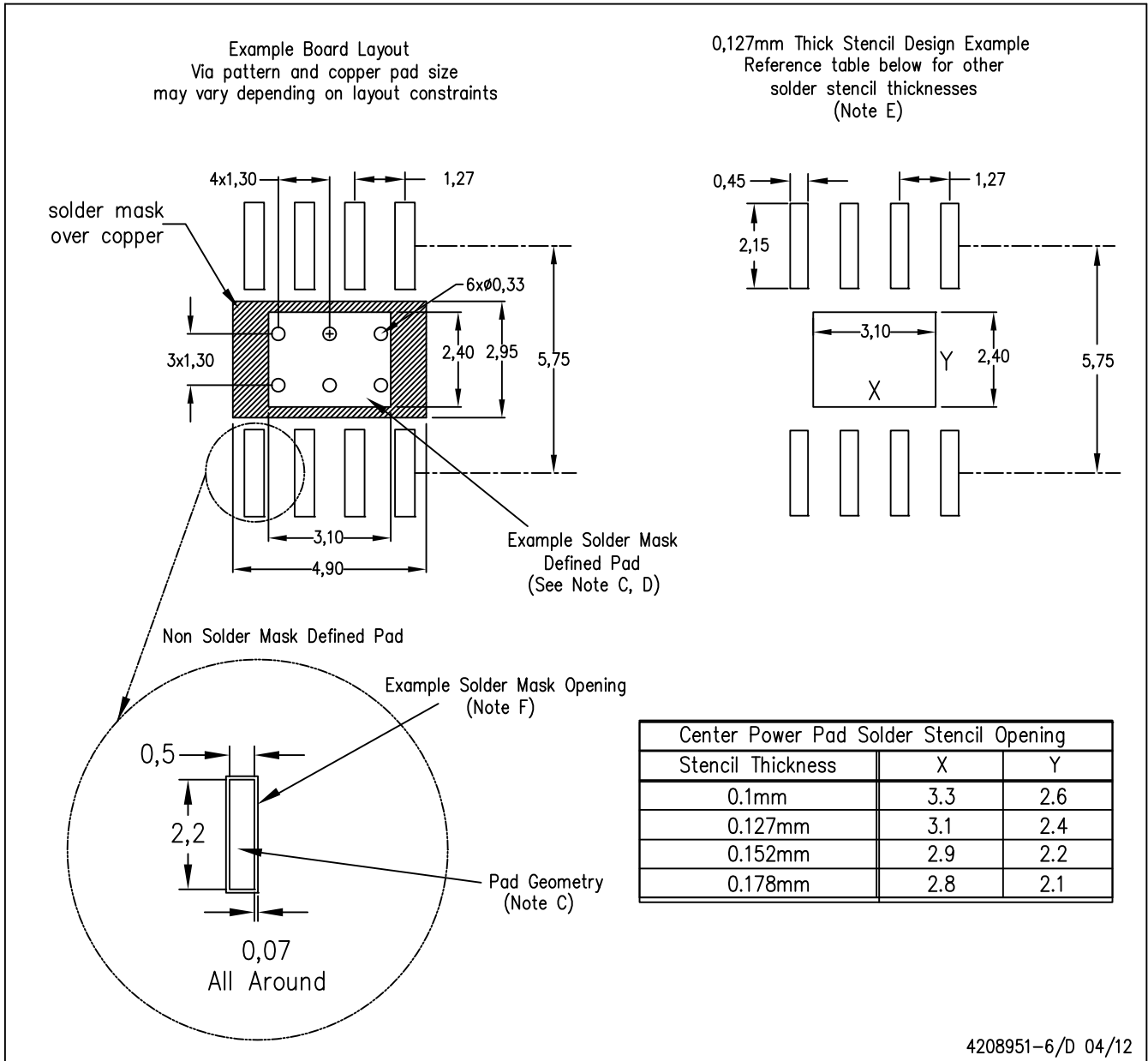

- NOTES:
- A. All linear dimensions are in millimeters.
  - B. This drawing is subject to change without notice.
  - C. Publication IPC-7351 is recommended for alternate designs.
  - D. This package is designed to be soldered to a thermal pad on the board. Refer to Technical Brief, PowerPad Thermally Enhanced Package, Texas Instruments Literature No. SLMA002, SLMA004, and also the Product Data Sheets for specific thermal information, via requirements, and recommended board layout. These documents are available at [www.ti.com](http://www.ti.com) <<http://www.ti.com>>. Publication IPC-7351 is recommended for alternate designs.
  - E. Laser cutting apertures with trapezoidal walls and also rounding corners will offer better paste release. Customers should contact their board assembly site for stencil design recommendations. Example stencil design based on a 50% volumetric metal load solder paste. Refer to IPC-7525 for other stencil recommendations.
  - F. Customers should contact their board fabrication site for solder mask tolerances between and around signal pads.

PowerPAD is a trademark of Texas Instruments.

## IMPORTANT NOTICE AND DISCLAIMER

TI PROVIDES TECHNICAL AND RELIABILITY DATA (INCLUDING DATA SHEETS), DESIGN RESOURCES (INCLUDING REFERENCE DESIGNS), APPLICATION OR OTHER DESIGN ADVICE, WEB TOOLS, SAFETY INFORMATION, AND OTHER RESOURCES "AS IS" AND WITH ALL FAULTS, AND DISCLAIMS ALL WARRANTIES, EXPRESS AND IMPLIED, INCLUDING WITHOUT LIMITATION ANY IMPLIED WARRANTIES OF MERCHANTABILITY, FITNESS FOR A PARTICULAR PURPOSE OR NON-INFRINGEMENT OF THIRD PARTY INTELLECTUAL PROPERTY RIGHTS.

These resources are intended for skilled developers designing with TI products. You are solely responsible for (1) selecting the appropriate TI products for your application, (2) designing, validating and testing your application, and (3) ensuring your application meets applicable standards, and any other safety, security, regulatory or other requirements.

These resources are subject to change without notice. TI grants you permission to use these resources only for development of an application that uses the TI products described in the resource. Other reproduction and display of these resources is prohibited. No license is granted to any other TI intellectual property right or to any third party intellectual property right. TI disclaims responsibility for, and you will fully indemnify TI and its representatives against, any claims, damages, costs, losses, and liabilities arising out of your use of these resources.

TI's products are provided subject to [TI's Terms of Sale](#) or other applicable terms available either on [ti.com](http://ti.com) or provided in conjunction with such TI products. TI's provision of these resources does not expand or otherwise alter TI's applicable warranties or warranty disclaimers for TI products.

TI objects to and rejects any additional or different terms you may have proposed.

Mailing Address: Texas Instruments, Post Office Box 655303, Dallas, Texas 75265  
Copyright © 2022, Texas Instruments Incorporated