

SN54HC163, SN74HC163 4-BIT SYNCHRONOUS BINARY COUNTERS

SCLS298D – JANUARY 1996 – REVISED – OCTOBER 2003

- Wide Operating Voltage Range of 2 V to 6 V
- Outputs Can Drive Up To 10 LSTTL Loads
- Low Power Consumption, 80- μ A Max I_{CC}
- Typical $t_{pd} = 14$ ns
- ± 4 -mA Output Drive at 5 V
- Low Input Current of 1 μ A Max
- Internal Look-Ahead for Fast Counting
- Carry Output for n-Bit Cascading
- Synchronous Counting
- Synchronously Programmable

SN54HC163 . . . J OR W PACKAGE
SN74HC163 . . . D, DB, N, NS, OR PW PACKAGE
(TOP VIEW)

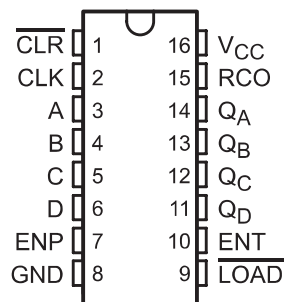

description/ordering information

These synchronous, presettable counters feature an internal carry look-ahead for application in high-speed counting designs. The 'HC163 devices are 4-bit binary counters. Synchronous operation is provided by having all flip-flops clocked simultaneously so that the outputs change coincident with each other when instructed by the count-enable (ENP, ENT) inputs and internal gating. This mode of operation eliminates the output counting spikes normally associated with synchronous (ripple-clock) counters. A buffered clock (CLK) input triggers the four flip-flops on the rising (positive-going) edge of the clock waveform.

SN54HC163 . . . FK PACKAGE
(TOP VIEW)

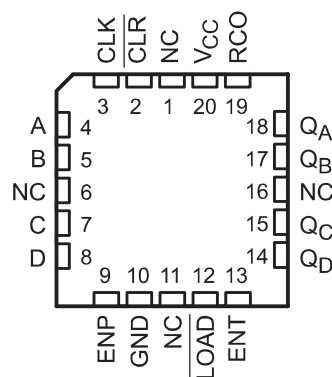

NC – No internal connection

ORDERING INFORMATION

T _A	PACKAGE†		ORDERABLE PART NUMBER	TOP-SIDE MARKING
-40°C to 85°C	PDIP – N	Tube of 25	SN74HC163N	SN74HC163N
	SOIC – D	Tube of 40	SN74HC163D	HC163
		Reel of 2500	SN74HC163DR	
		Reel of 250	SN74HC163DT	
	SOP – NS	Reel of 2000	SN74HC163NSR	HC163
	SSOP – DB	Reel of 2000	SN74HC163DBR	HC163
-55°C to 125°C	TSSOP – PW	Tube of 90	SN74HC163PW	HC163
		Reel of 2000	SN74HC163PWR	
		Reel of 250	SN74HC163PWT	
-55°C to 125°C	CDIP – J	Tube of 25	SNJ54HC163J	SNJ54HC163J
	CFP – W	Tube of 150	SNJ54HC163W	SNJ54HC163W
	LCCC – FK	Tube of 55	SNJ54HC163FK	SNJ54HC163FK

† Package drawings, standard packing quantities, thermal data, symbolization, and PCB design guidelines are available at www.ti.com/sc/package.



Please be aware that an important notice concerning availability, standard warranty, and use in critical applications of Texas Instruments semiconductor products and disclaimers thereto appears at the end of this data sheet.

PRODUCTION DATA information is current as of publication date. Products conform to specifications per the terms of Texas Instruments standard warranty. Production processing does not necessarily include testing of all parameters.

 **TEXAS
INSTRUMENTS**

POST OFFICE BOX 655303 • DALLAS, TEXAS 75265

Copyright © 2003, Texas Instruments Incorporated
On products compliant to MIL-PRF-38535, all parameters are tested unless otherwise noted. On all other products, production processing does not necessarily include testing of all parameters.

SN54HC163, SN74HC163

4-BIT SYNCHRONOUS BINARY COUNTERS

SCLS298D – JANUARY 1996 – REVISED – OCTOBER 2003

description/ordering information (continued)

These counters are fully programmable; that is, they can be preset to any number between 0 and 9 or 15. As presetting is synchronous, setting up a low level at the load input disables the counter and causes the outputs to agree with the setup data after the next clock pulse, regardless of the levels of the enable inputs.

The clear function for the 'HC163 devices is synchronous. A low level at the clear ($\overline{\text{CLR}}$) input sets all four of the flip-flop outputs low after the next low-to-high transition of CLK, regardless of the levels of the enable inputs. This synchronous clear allows the count length to be modified easily by decoding the Q outputs for the maximum count desired. The active-low output of the gate used for decoding is connected to $\overline{\text{CLR}}$ to synchronously clear the counter to 0000 (LLLL).

The carry look-ahead circuitry provides for cascading counters for n-bit synchronous applications without additional gating. ENP, ENT, and a ripple-carry output (RCO) are instrumental in accomplishing this function. Both ENP and ENT must be high to count, and ENT is fed forward to enable RCO. Enabling RCO produces a high-level pulse while the count is maximum (9 or 15 with Q_A high). This high-level overflow ripple-carry pulse can be used to enable successive cascaded stages. Transitions at ENP or ENT are allowed, regardless of the level of CLK.

These counters feature a fully independent clock circuit. Changes at control inputs (ENP, ENT, or $\overline{\text{LOAD}}$) that modify the operating mode have no effect on the contents of the counter until clocking occurs. The function of the counter (whether enabled, disabled, loading, or counting) is dictated solely by the conditions meeting the stable setup and hold times.



POST OFFICE BOX 655303 • DALLAS, TEXAS 75265

SN54HC163, SN74HC163 4-BIT SYNCHRONOUS BINARY COUNTERS

SCLS298D - JANUARY 1996 - REVISED - OCTOBER 2003

logic diagram (positive logic)

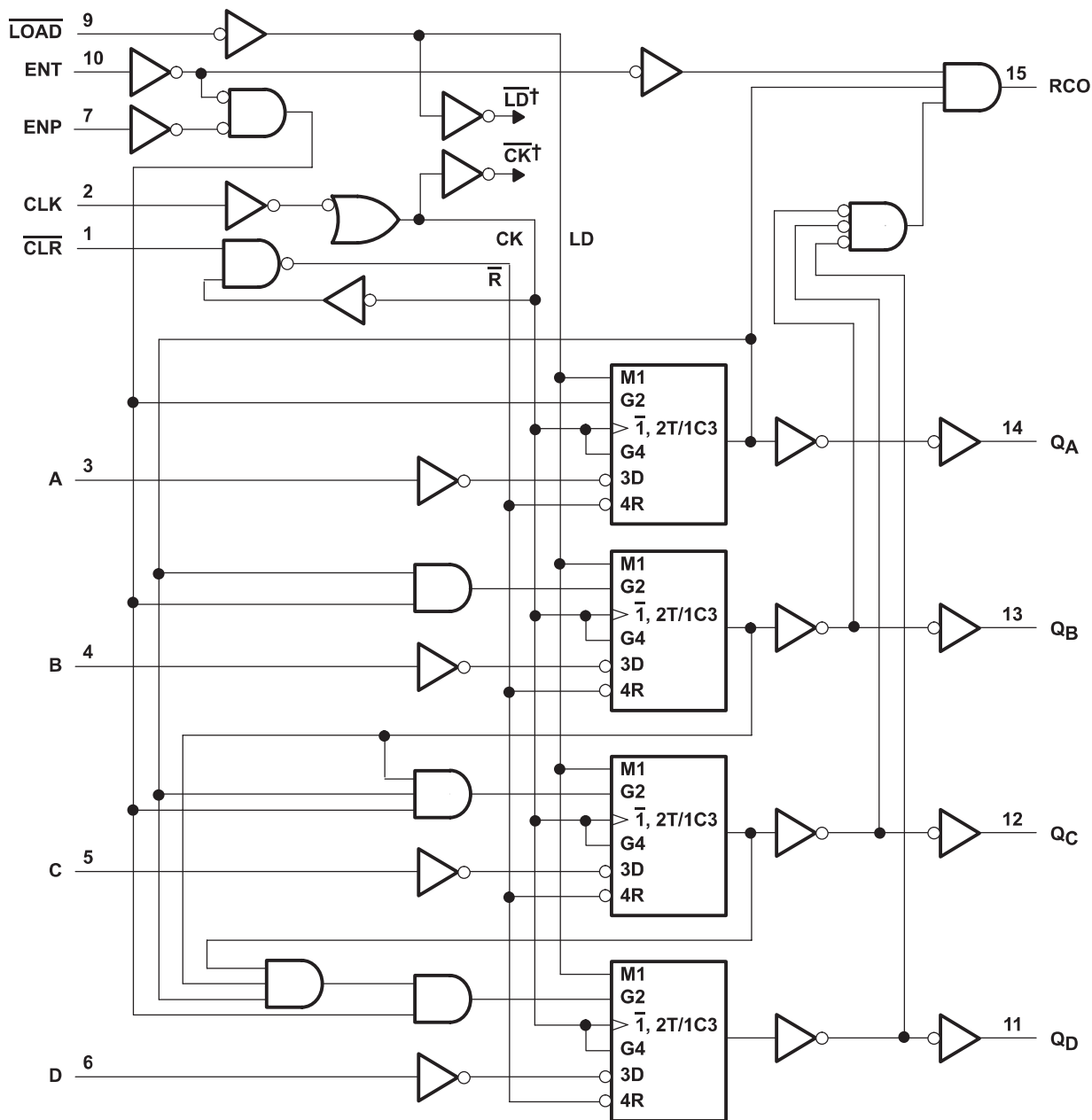

† For simplicity, routing of complementary signals \overline{LD} and \overline{CK} is not shown on this overall logic diagram. The uses of these signals are shown on the logic diagram of the D/T flip-flops.
Pin numbers shown are for the D, DB, J, N, NS, PW, and W packages.



POST OFFICE BOX 655303 • DALLAS, TEXAS 75265

SN54HC163, SN74HC163 4-BIT SYNCHRONOUS BINARY COUNTERS

SCLS298D - JANUARY 1996 - REVISED - OCTOBER 2003

logic symbol, each D/T flip-flop

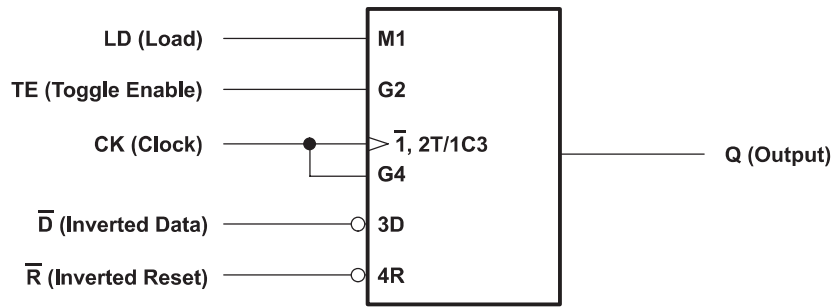

logic diagram, each D/T flip-flop (positive logic)

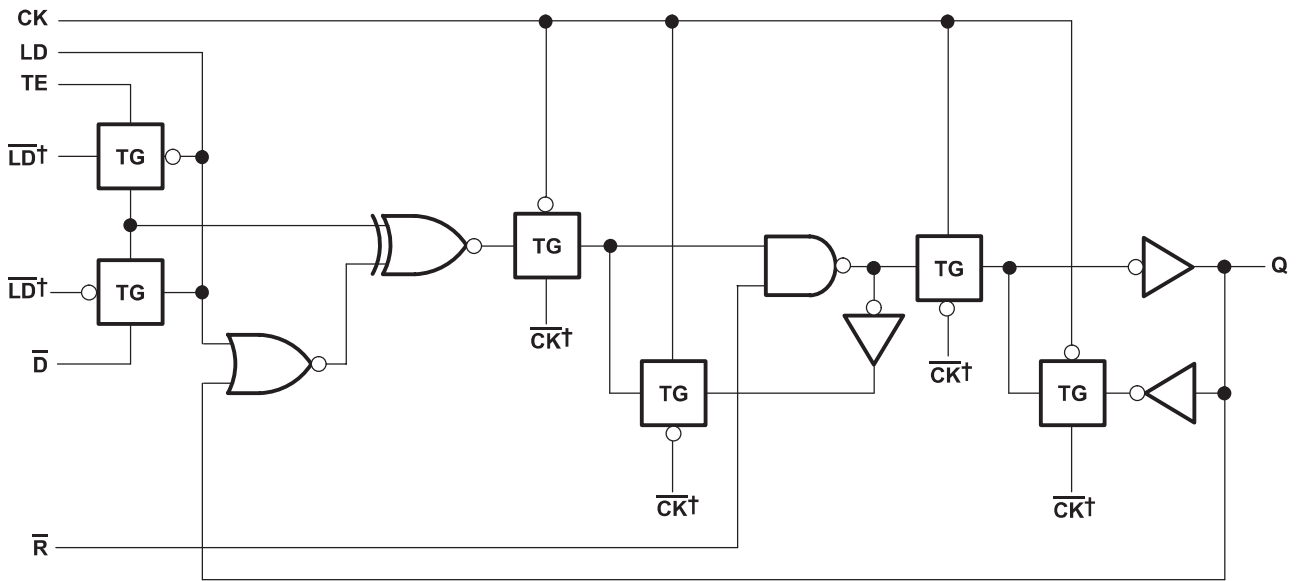

† The origins of \overline{LD} and \overline{CK} are shown in the logic diagram of the overall device.

typical clear, preset, count, and inhibit sequence

The following sequence is illustrated below:

1. Clear outputs to zero (synchronous)
2. Preset to binary 12
3. Count to 13, 14, 15, 0, 1, and 2
4. Inhibit

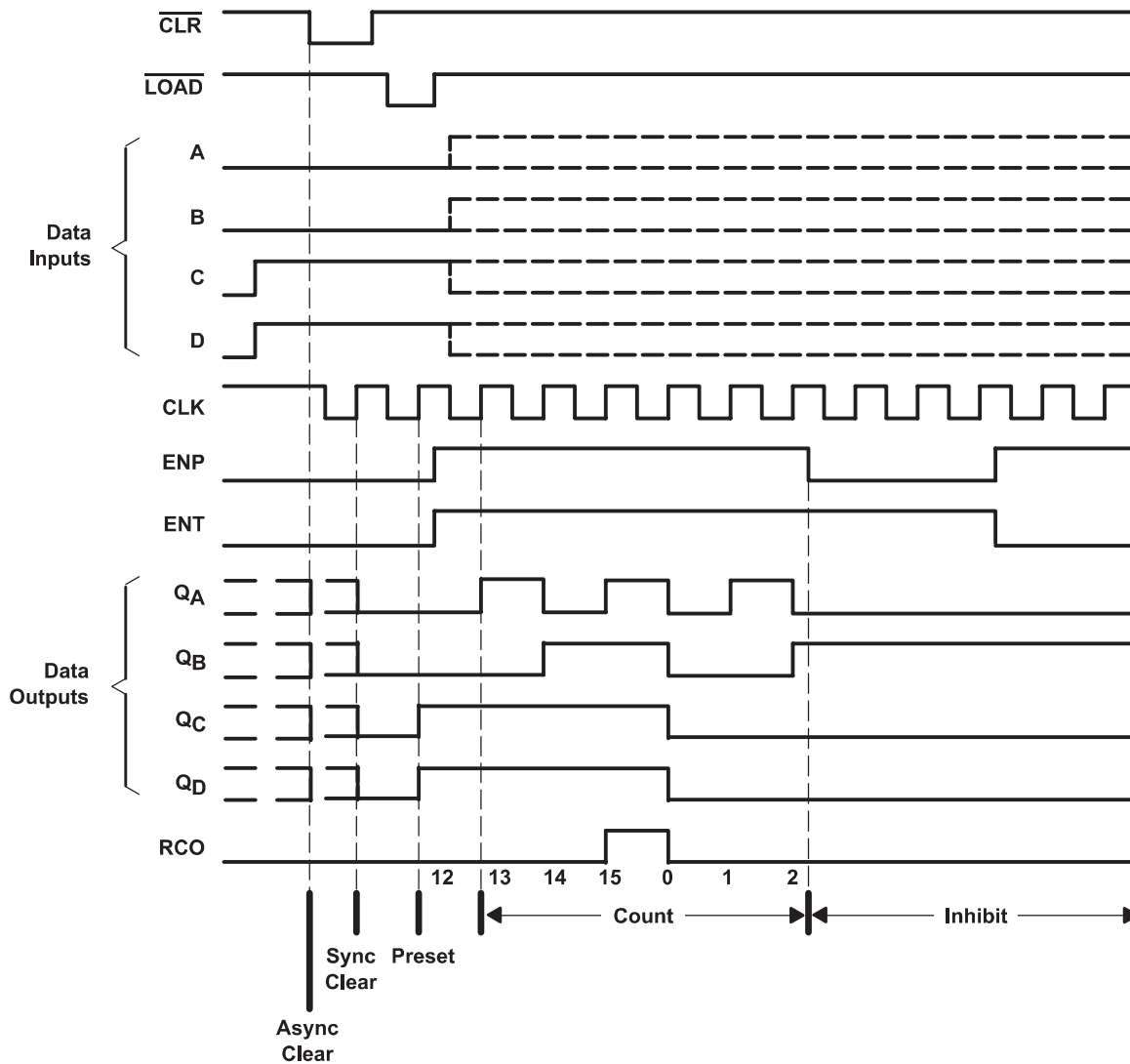

SN54HC163, SN74HC163

4-BIT SYNCHRONOUS BINARY COUNTERS

SCLS298D – JANUARY 1996 – REVISED – OCTOBER 2003

absolute maximum ratings over operating free-air temperature range (unless otherwise noted)†

Supply voltage range, V_{CC}	-0.5 V to 7 V
Input clamp current, I_{IK} ($V_I < 0$ or $V_I > V_{CC}$) (see Note 1)	± 20 mA
Output clamp current, I_{OK} ($V_O < 0$ or $V_O > V_{CC}$) (see Note 1)	± 20 mA
Continuous output current, I_O ($V_O = 0$ to V_{CC})	± 25 mA
Continuous current through V_{CC} or GND	± 50 mA
Package thermal impedance, θ_{JA} (see Note 2): D package	73°C/W
DB package	82°C/W
N package	67°C/W
NS package	64°C/W
PW package	108°C/W
Storage temperature range, T_{stg}	-65°C to 150°C

† Stresses beyond those listed under “absolute maximum ratings” may cause permanent damage to the device. These are stress ratings only, and functional operation of the device at these or any other conditions beyond those indicated under “recommended operating conditions” is not implied. Exposure to absolute-maximum-rated conditions for extended periods may affect device reliability.

- NOTES: 1. The input and output voltage ratings may be exceeded if the input and output current ratings are observed.
 2. The package thermal impedance is calculated in accordance with JESD 51-7.

recommended operating conditions (see Note 3)

		SN54HC163			SN74HC163			UNIT
		MIN	NOM	MAX	MIN	NOM	MAX	
V_{CC}	Supply voltage	2	5	6	2	5	6	V
V_{IH}	High-level input voltage	$V_{CC} = 2$ V		1.5	1.5		V	
		$V_{CC} = 4.5$ V		3.15	3.15			
		$V_{CC} = 6$ V		4.2	4.2			
V_{IL}	Low-level input voltage	$V_{CC} = 2$ V			0.5		V	
		$V_{CC} = 4.5$ V			1.35			
		$V_{CC} = 6$ V			1.8			
V_I	Input voltage	0		V_{CC}	0		V_{CC}	V
V_O	Output voltage	0		V_{CC}	0		V_{CC}	V
$\Delta t/\Delta v^\ddagger$	Input transition rise/fall time	$V_{CC} = 2$ V			1000		ns	
		$V_{CC} = 4.5$ V			500			
		$V_{CC} = 6$ V			400			
T_A	Operating free-air temperature	-55		125	-40		85	°C

NOTE 3: All unused inputs of the device must be held at V_{CC} or GND to ensure proper device operation. Refer to the TI application report, *Implications of Slow or Floating CMOS Inputs*, literature number SCBA004.

‡ If this device is used in the threshold region (from $V_{ILmax} = 0.5$ V to $V_{IHmin} = 1.5$ V), there is a potential to go into the wrong state from induced grounding, causing double clocking. Operating with the inputs at $t_f = 1000$ ns and $V_{CC} = 2$ V does not damage the device; however, functionally, the CLK inputs are not ensured while in the shift, count, or toggle operating modes.



POST OFFICE BOX 655303 • DALLAS, TEXAS 75265

SN54HC163, SN74HC163 4-BIT SYNCHRONOUS BINARY COUNTERS

SCLS298D – JANUARY 1996 – REVISED – OCTOBER 2003

electrical characteristics over recommended operating free-air temperature range (unless otherwise noted)

PARAMETER	TEST CONDITIONS	V _{CC}	T _A = 25°C			SN54HC163		SN74HC163		UNIT
			MIN	TYP	MAX	MIN	MAX	MIN	MAX	
V _{OH}	V _I = V _{IH} or V _{IL}	I _{OH} = -20 μA	2 V	1.9	1.998	1.9	1.9	V		
			4.5 V	4.4	4.499	4.4	4.4			
			6 V	5.9	5.999	5.9	5.9			
		I _{OH} = -4 mA	4.5 V	3.98	4.3	3.7	3.84			
			6 V	5.48	5.8	5.2	5.34			
V _{OL}	V _I = V _{IH} or V _{IL}	I _{OL} = 20 μA	2 V	0.002	0.1	0.1	0.1	V		
			4.5 V	0.001	0.1	0.1	0.1			
			6 V	0.001	0.1	0.1	0.1			
		I _{OL} = 4 mA	4.5 V	0.17	0.26	0.4	0.33			
			6 V	0.15	0.26	0.4	0.33			
I _I	V _I = V _{CC} or 0	6 V	±0.1	±100	±1000	±1000	nA			
I _{CC}	V _I = V _{CC} or 0, I _O = 0	6 V		8	160	80	μA			
C _i		2 V to 6 V		3	10	10	10	pF		

timing requirements over recommended operating free-air temperature range (unless otherwise noted)

	V _{CC}	T _A = 25°C		SN54HC163		SN74HC163		UNIT
		MIN	MAX	MIN	MAX	MIN	MAX	
f _{clock} Clock frequency	2 V		6	4.2	5	MHz		
	4.5 V		31	21	25			
	6 V		36	25	29			
t _w Pulse duration	CLK high or low	2 V	80	120	100	ns		
		4.5 V	16	24	20			
		6 V	14	20	17			
t _{su} Setup time before CLK↑	A, B, C, or D	2 V	150	225	190	ns		
		4.5 V	30	45	38			
		6 V	26	38	32			
	LOAD low	2 V	135	205	170			
		4.5 V	27	41	34			
		6 V	23	35	29			
	ENP, ENT	2 V	170	255	215			
		4.5 V	34	51	43			
		6 V	29	43	37			
	CLR low	2 V	160	240	200			
		4.5 V	32	48	40			
		6 V	27	41	34			
	CLR inactive	2 V	160	240	200			
		4.5 V	32	48	40			
		6 V	27	41	34			
t _h Hold time, all synchronous inputs after CLK↑	2 V	0	0	0	ns			
	4.5 V	0	0	0				
	6 V	0	0	0				



SN54HC163, SN74HC163

4-BIT SYNCHRONOUS BINARY COUNTERS

SCLS298D – JANUARY 1996 – REVISED – OCTOBER 2003

switching characteristics over recommended operating free-air temperature range, $C_L = 50 \text{ pF}$ (unless otherwise noted) (see Figure 1)

PARAMETER	FROM (INPUT)	TO (OUTPUT)	V_{CC}	$T_A = 25^\circ\text{C}$			SN54HC163		SN74HC163		UNIT
				MIN	TYP	MAX	MIN	MAX	MIN	MAX	
f_{\max}			2 V	6	14		4.2		5	MHz	
			4.5 V	31	40		21		25		
			6 V	36	44		25		29		
t_{pd}	CLK	RCO	2 V		83	215		325		270	ns
			4.5 V		24	43		65		54	
			6 V		20	37		55		46	
		Any Q	2 V		80	205		310		255	
			4.5 V		25	41		62		51	
			6 V		21	35		53		43	
	ENT	RCO	2 V		62	195		295		245	
			4.5 V		17	39		59		49	
			6 V		14	33		50		42	
t_t		Any	2 V		38	75		110		95	ns
			4.5 V		8	15		22		19	
			6 V		6	13		19		16	

operating characteristics, $T_A = 25^\circ\text{C}$

PARAMETER	TEST CONDITIONS	TYP	UNIT
C_{pd} Power dissipation capacitance	No load	60	pF



POST OFFICE BOX 655303 • DALLAS, TEXAS 75265

PARAMETER MEASUREMENT INFORMATION

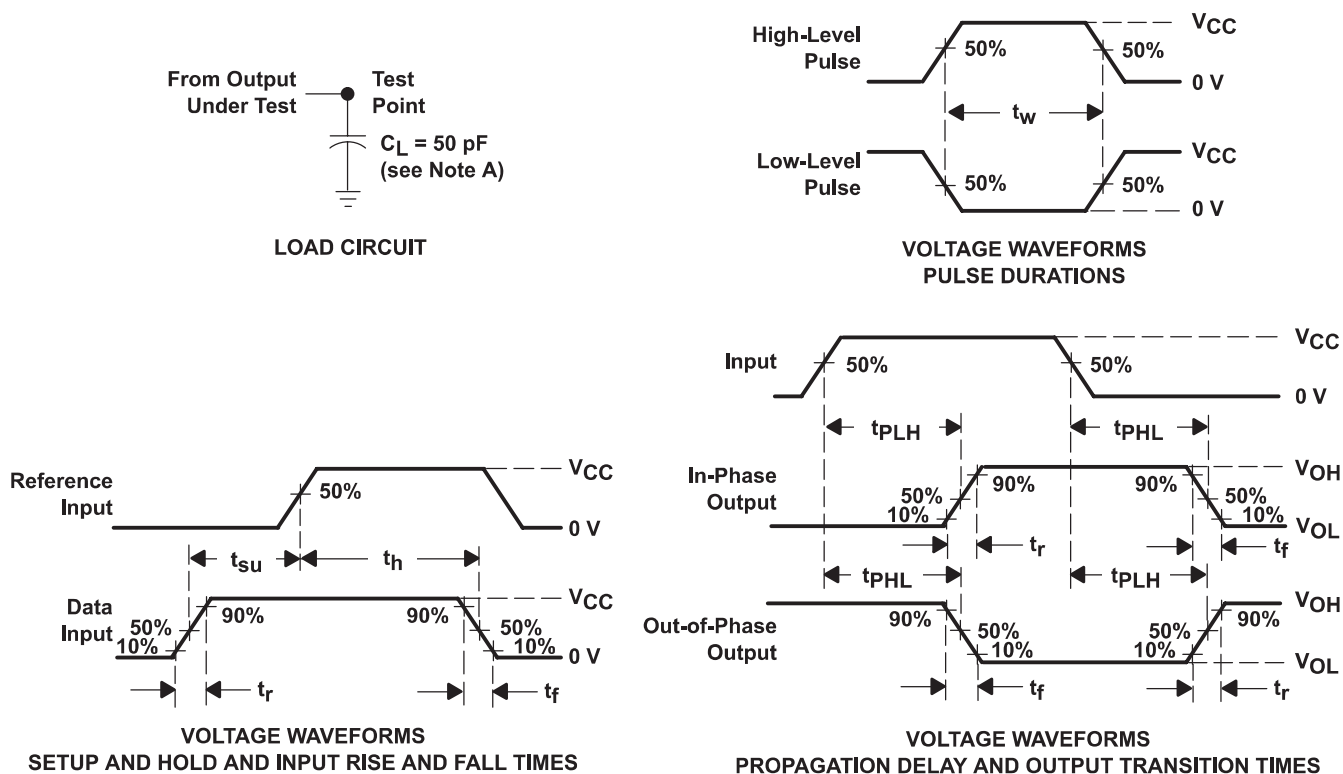

- NOTES: A. C_L includes probe and test-fixture capacitance.
 B. Phase relationships between waveforms were chosen arbitrarily. All input pulses are supplied by generators having the following characteristics: $PRR \leq 1 \text{ MHz}$, $Z_O = 50 \Omega$, $t_r = 6 \text{ ns}$, $t_f = 6 \text{ ns}$.
 C. For clock inputs, f_{max} is measured when the input duty cycle is 50%.
 D. The outputs are measured one at a time with one input transition per measurement.
 E. t_{pLH} and t_{pHL} are the same as t_{pd} .

Figure 1. Load Circuit and Voltage Waveforms

SN54HC163, SN74HC163 4-BIT SYNCHRONOUS BINARY COUNTERS

SCLS298D - JANUARY 1996 - REVISED - OCTOBER 2003

APPLICATION INFORMATION

n-bit synchronous counters

This application demonstrates how the look-ahead carry circuit can be used to implement a high-speed n-bit counter. The 'HC163 devices count in binary. Virtually any count mode (modulo-N, N₁-to-N₂, N₁-to-maximum) can be used with this fast look-ahead circuit.

The application circuit shown in Figure 2 is not valid for clock frequencies above 18 MHz (at 25°C and 4.5-V V_{CC}). The reason for this is that there is a glitch that is produced on the second stage's RCO and every succeeding stage's RCO. This glitch is common to all HC vendors that Texas Instruments has evaluated, in addition to the bipolar equivalents (LS, ALS, AS).



POST OFFICE BOX 655303 • DALLAS, TEXAS 75265

APPLICATION INFORMATION

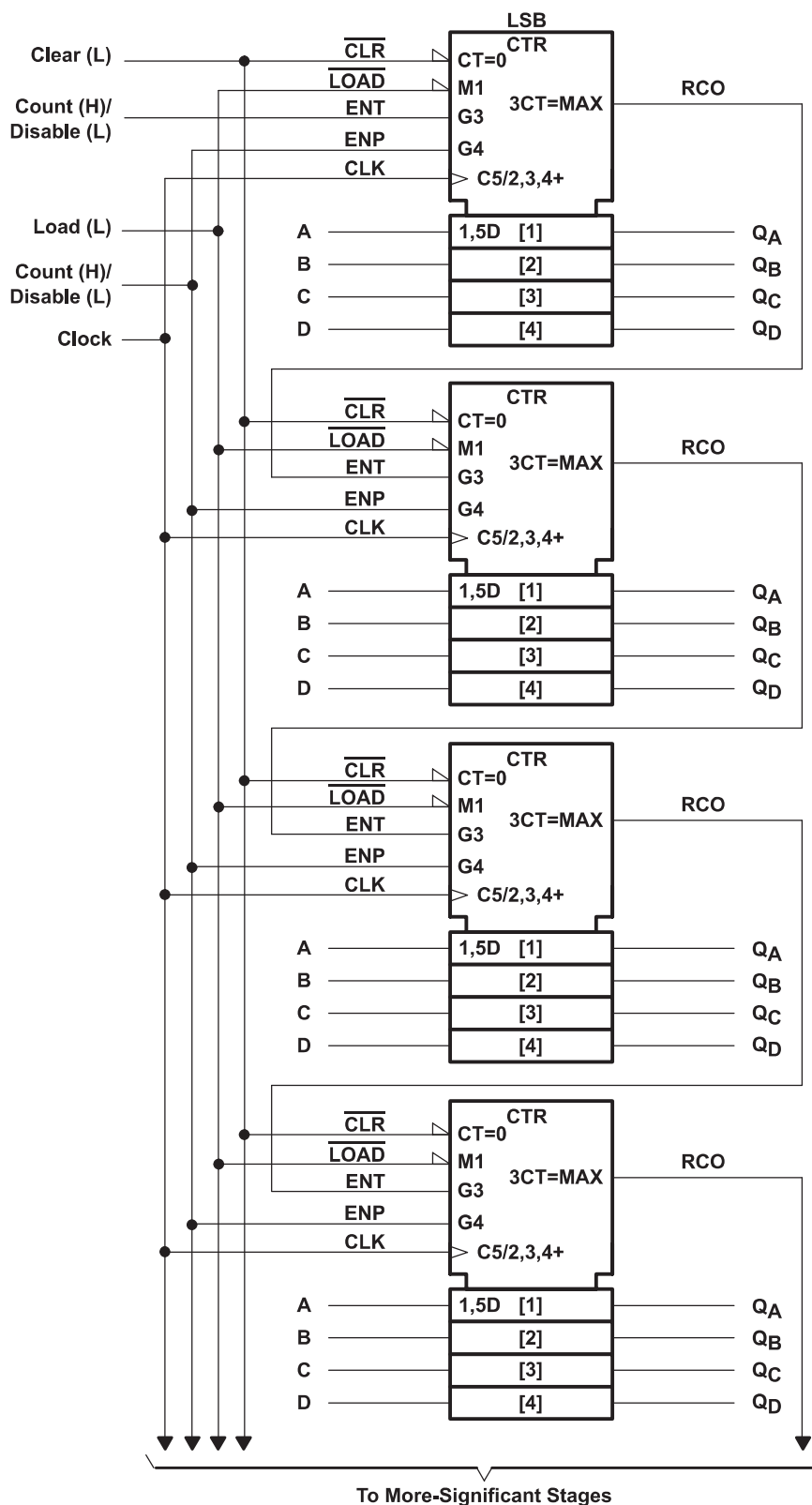

Figure 2



SN54HC163, SN74HC163 4-BIT SYNCHRONOUS BINARY COUNTERS

SCLS298D – JANUARY 1996 – REVISED – OCTOBER 2003

APPLICATION INFORMATION

n-bit synchronous counters (continued)

The glitch on RCO is caused because the propagation delay of the rising edge of Q_A of the second stage is shorter than the propagation delay of the falling edge of ENT. RCO is the product of ENT, Q_A , Q_B , Q_C , and Q_D ($ENT \times Q_A \times Q_B \times Q_C \times Q_D$). The resulting glitch is about 7–12 ns in duration. Figure 3 shows the condition in which the glitch occurs. For simplicity, only two stages are being considered, but the results can be applied to other stages. Q_B , Q_C , and Q_D of the first and second stage are at logic one, and Q_A of both stages are at logic zero (1110 1110) after the first clock pulse. On the rising edge of the second clock pulse, Q_A and RCO of the first stage go high. On the rising edge of the third clock pulse, Q_A and RCO of the first stage return to a low level, and Q_A of the second stage goes to a high level. At this time, the glitch on RCO of the second stage appears because of the race condition inside the chip.

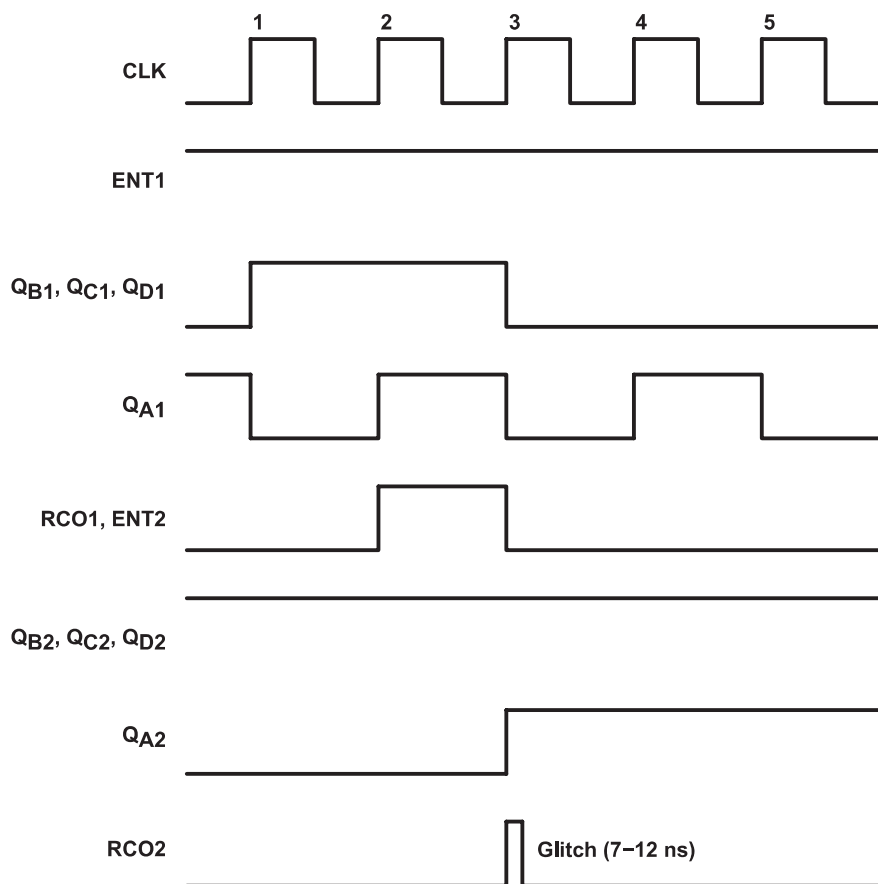

Figure 3

The glitch causes a problem in the next stage (stage three) if the glitch is still present when the next rising clock edge appears (clock pulse 4). To ensure that this does not happen, the clock frequency must be less than the inverse of the sum of the clock-to-RCO propagation delay and the glitch duration (t_g). In other words, $f_{max} = 1/(t_{pd\ CLK-to-RCO} + t_g)$. For example, at 25°C at 4.5-V V_{CC} , the clock-to-RCO propagation delay is 43 ns and the maximum duration of the glitch is 12 ns. Therefore, the maximum clock frequency that the cascaded counters can use is 18 MHz. The following tables contain the f_{clock} , t_w , and f_{max} specifications for applications that use more than two 'HC163 devices cascaded together.

APPLICATION INFORMATION

n-bit synchronous counters (continued)

timing requirements over recommended operating free-air temperature range (unless otherwise noted)

	V _{CC}	T _A = 25°C		SN54HC163		SN74HC163		UNIT
		MIN	MAX	MIN	MAX	MIN	MAX	
f _{clock} Clock frequency	2 V		3.6		2.5		2.9	MHz
	4.5 V		18		12		14	
	6 V		21		14		17	
t _w Pulse duration, CLK high or low	2 V	140		200		170		ns
	4.5 V	28		40		36		
	6 V	24		36		30		

switching characteristics over recommended operating free-air temperature range, C_L = 50 pF (unless otherwise noted) (see Note 4)

PARAMETER	FROM (INPUT)	TO (OUTPUT)	V _{CC}	T _A = 25°C		SN54HC163		SN74HC163		UNIT
				MIN	MAX	MIN	MAX	MIN	MAX	
f _{max}			2 V	3.6		2.5		2.9		MHz
			4.5 V	18		12		14		
			6 V	21		14		17		

NOTE 4: These limits apply only to applications that use more than two 'HC163 devices cascaded together.

If the 'HC163 devices are used as a single unit, or only two cascaded together, then the maximum clock frequency that the devices can use is not limited because of the glitch. In these situations, the devices can be operated at the maximum specifications.

A glitch can appear on RCO of a single 'HC163 device, depending on the relationship of ENT to CLK. Any application that uses RCO to drive any input, except an ENT of another cascaded 'HC163 device, must take this into consideration.

PACKAGING INFORMATION

Orderable Device	Status (1)	Package Type	Package Drawing	Package Pins	Package Qty	Eco Plan (2)	Lead finish/ Ball material (6)	MSL Peak Temp (3)	Op Temp (°C)	Device Marking (4/5)	Samples
86076012A	ACTIVE	LCCC	FK	20	1	Non-RoHS & Green	POST-PLATE	N / A for Pkg Type	-55 to 125	86076012A SNJ54HC 163FK	Samples
8607601EA	ACTIVE	CDIP	J	16	1	Non-RoHS & Green	SNPB	N / A for Pkg Type	-55 to 125	8607601EA SNJ54HC163J	Samples
JM38510/66304BEA	ACTIVE	CDIP	J	16	1	Non-RoHS & Green	SNPB	N / A for Pkg Type	-55 to 125	JM38510/ 66304BEA	Samples
M38510/66304BEA	ACTIVE	CDIP	J	16	1	Non-RoHS & Green	SNPB	N / A for Pkg Type	-55 to 125	JM38510/ 66304BEA	Samples
SN54HC163J	ACTIVE	CDIP	J	16	1	Non-RoHS & Green	SNPB	N / A for Pkg Type	-55 to 125	SN54HC163J	Samples
SN74HC163D	ACTIVE	SOIC	D	16	40	RoHS & Green	NIPDAU	Level-1-260C-UNLIM	-40 to 85	HC163	Samples
SN74HC163DR	ACTIVE	SOIC	D	16	2500	RoHS & Green	NIPDAU	Level-1-260C-UNLIM	-40 to 85	HC163	Samples
SN74HC163DRE4	ACTIVE	SOIC	D	16	2500	RoHS & Green	NIPDAU	Level-1-260C-UNLIM	-40 to 85	HC163	Samples
SN74HC163DT	ACTIVE	SOIC	D	16	250	RoHS & Green	NIPDAU	Level-1-260C-UNLIM	-40 to 85	HC163	Samples
SN74HC163N	ACTIVE	PDIP	N	16	25	RoHS & Green	NIPDAU	N / A for Pkg Type	-40 to 85	SN74HC163N	Samples
SN74HC163NE4	ACTIVE	PDIP	N	16	25	RoHS & Green	NIPDAU	N / A for Pkg Type	-40 to 85	SN74HC163N	Samples
SN74HC163NSR	ACTIVE	SO	NS	16	2000	RoHS & Green	NIPDAU	Level-1-260C-UNLIM	-40 to 85	HC163	Samples
SN74HC163PW	ACTIVE	TSSOP	PW	16	90	RoHS & Green	NIPDAU	Level-1-260C-UNLIM	-40 to 85	HC163	Samples
SN74HC163PWR	ACTIVE	TSSOP	PW	16	2000	RoHS & Green	NIPDAU	Level-1-260C-UNLIM	-40 to 85	HC163	Samples
SN74HC163PWT	ACTIVE	TSSOP	PW	16	250	RoHS & Green	NIPDAU	Level-1-260C-UNLIM	-40 to 85	HC163	Samples
SNJ54HC163FK	ACTIVE	LCCC	FK	20	1	Non-RoHS & Green	POST-PLATE	N / A for Pkg Type	-55 to 125	86076012A SNJ54HC 163FK	Samples
SNJ54HC163J	ACTIVE	CDIP	J	16	1	Non-RoHS & Green	SNPB	N / A for Pkg Type	-55 to 125	8607601EA SNJ54HC163J	Samples

(1) The marketing status values are defined as follows:

ACTIVE: Product device recommended for new designs.

LIFEBUY: TI has announced that the device will be discontinued, and a lifetime-buy period is in effect.

NRND: Not recommended for new designs. Device is in production to support existing customers, but TI does not recommend using this part in a new design.

PREVIEW: Device has been announced but is not in production. Samples may or may not be available.

OBSOLETE: TI has discontinued the production of the device.

(2) **RoHS:** TI defines "RoHS" to mean semiconductor products that are compliant with the current EU RoHS requirements for all 10 RoHS substances, including the requirement that RoHS substance do not exceed 0.1% by weight in homogeneous materials. Where designed to be soldered at high temperatures, "RoHS" products are suitable for use in specified lead-free processes. TI may reference these types of products as "Pb-Free".

RoHS Exempt: TI defines "RoHS Exempt" to mean products that contain lead but are compliant with EU RoHS pursuant to a specific EU RoHS exemption.

Green: TI defines "Green" to mean the content of Chlorine (Cl) and Bromine (Br) based flame retardants meet JS709B low halogen requirements of ≤ 1000 ppm threshold. Antimony trioxide based flame retardants must also meet the ≤ 1000 ppm threshold requirement.

(3) **MSL, Peak Temp.** - The Moisture Sensitivity Level rating according to the JEDEC industry standard classifications, and peak solder temperature.

(4) There may be additional marking, which relates to the logo, the lot trace code information, or the environmental category on the device.

(5) Multiple Device Markings will be inside parentheses. Only one Device Marking contained in parentheses and separated by a "-" will appear on a device. If a line is indented then it is a continuation of the previous line and the two combined represent the entire Device Marking for that device.

(6) **Lead finish/Ball material** - Orderable Devices may have multiple material finish options. Finish options are separated by a vertical ruled line. Lead finish/Ball material values may wrap to two lines if the finish value exceeds the maximum column width.

Important Information and Disclaimer: The information provided on this page represents TI's knowledge and belief as of the date that it is provided. TI bases its knowledge and belief on information provided by third parties, and makes no representation or warranty as to the accuracy of such information. Efforts are underway to better integrate information from third parties. TI has taken and continues to take reasonable steps to provide representative and accurate information but may not have conducted destructive testing or chemical analysis on incoming materials and chemicals. TI and TI suppliers consider certain information to be proprietary, and thus CAS numbers and other limited information may not be available for release.

In no event shall TI's liability arising out of such information exceed the total purchase price of the TI part(s) at issue in this document sold by TI to Customer on an annual basis.

OTHER QUALIFIED VERSIONS OF SN54HC163, SN74HC163 :

- Catalog: [SN74HC163](#)
- Automotive: [SN74HC163-Q1](#), [SN74HC163-Q1](#)
- Military: [SN54HC163](#)



www.ti.com

NOTE: Qualified Version Definitions:

- Catalog - TI's standard catalog product
- Automotive - Q100 devices qualified for high-reliability automotive applications targeting zero defects
- Military - QML certified for Military and Defense Applications

21-Jan-2021

PACKAGE OPTION ADDENDUM

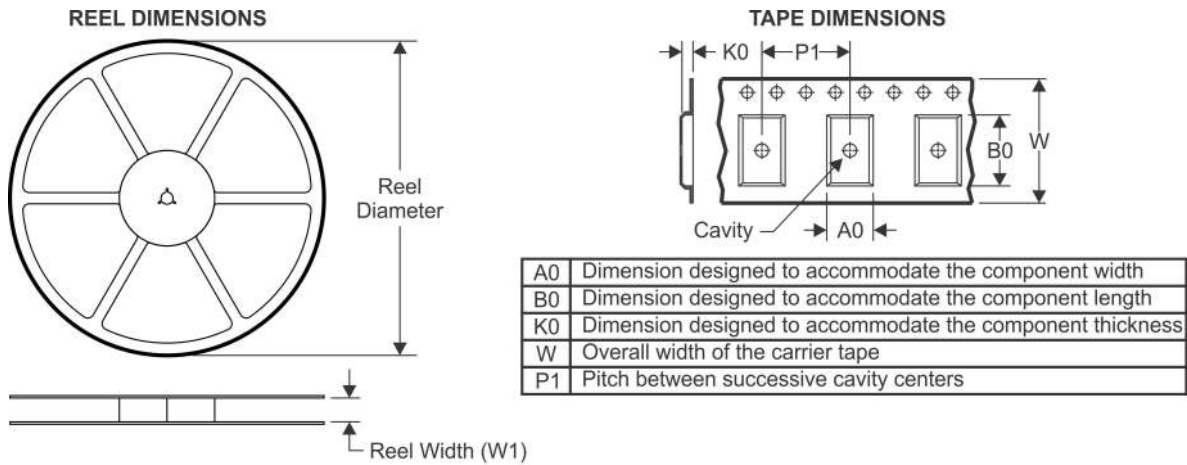
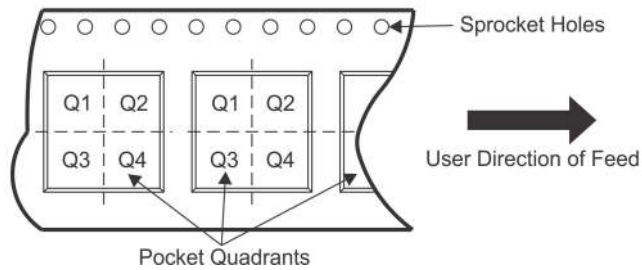
TAPE AND REEL INFORMATION

QUADRANT ASSIGNMENTS FOR PIN 1 ORIENTATION IN TAPE

*All dimensions are nominal

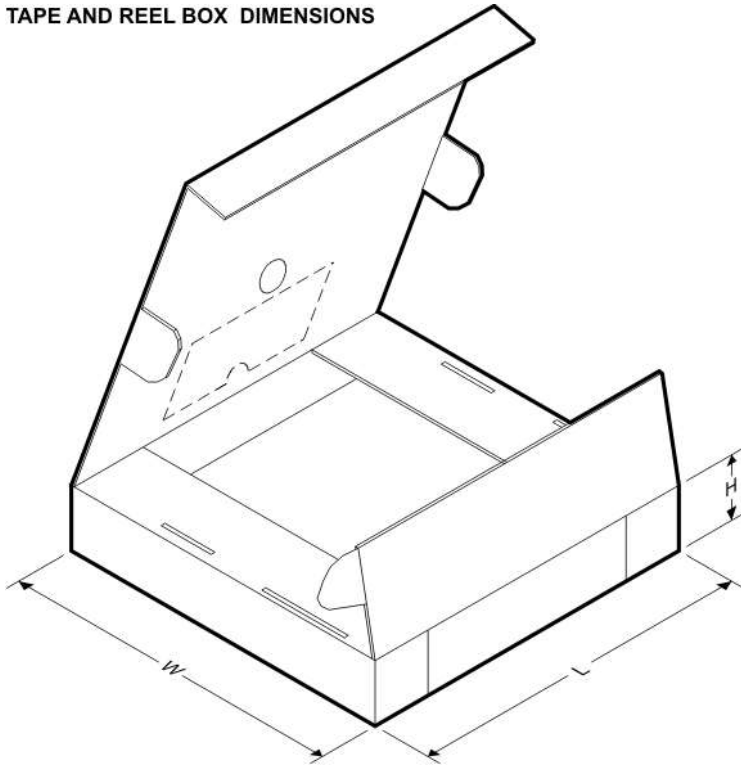
Device	Package Type	Package Drawing	Pins	SPQ	Reel Diameter (mm)	Reel Width W1 (mm)	A0 (mm)	B0 (mm)	K0 (mm)	P1 (mm)	W (mm)	Pin1 Quadrant
SN74HC163DR	SOIC	D	16	2500	330.0	16.4	6.5	10.3	2.1	8.0	16.0	Q1
SN74HC163NSR	SO	NS	16	2000	330.0	16.4	8.2	10.5	2.5	12.0	16.0	Q1
SN74HC163PWR	TSSOP	PW	16	2000	330.0	12.4	6.9	5.6	1.6	8.0	12.0	Q1
SN74HC163PWT	TSSOP	PW	16	250	330.0	12.4	6.9	5.6	1.6	8.0	12.0	Q1

TAPE AND REEL BOX DIMENSIONS

*All dimensions are nominal

Device	Package Type	Package Drawing	Pins	SPQ	Length (mm)	Width (mm)	Height (mm)
SN74HC163DR	SOIC	D	16	2500	333.2	345.9	28.6
SN74HC163NSR	SO	NS	16	2000	853.0	449.0	35.0
SN74HC163PWR	TSSOP	PW	16	2000	853.0	449.0	35.0
SN74HC163PWT	TSSOP	PW	16	250	853.0	449.0	35.0

FK (S-CQCC-N**)

LEADLESS CERAMIC CHIP CARRIER

28 TERMINAL SHOWN

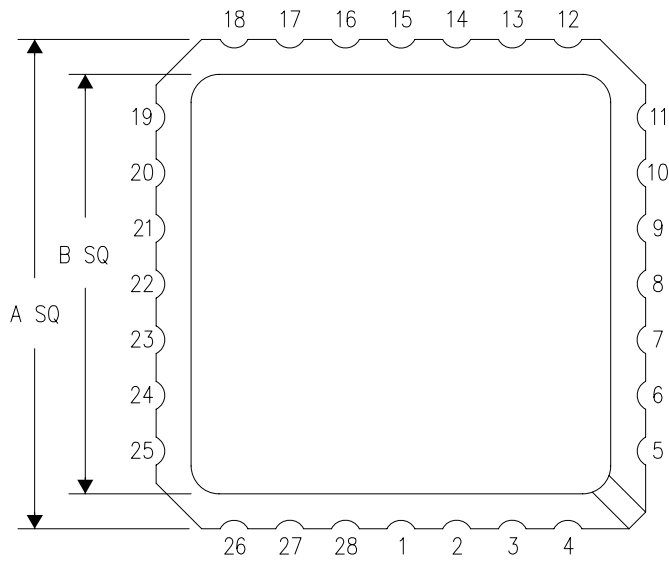

NO. OF TERMINALS **	A		B	
	MIN	MAX	MIN	MAX
20	0.342 (8,69)	0.358 (9,09)	0.307 (7,80)	0.358 (9,09)
28	0.442 (11,23)	0.458 (11,63)	0.406 (10,31)	0.458 (11,63)
44	0.640 (16,26)	0.660 (16,76)	0.495 (12,58)	0.560 (14,22)
52	0.740 (18,78)	0.761 (19,32)	0.495 (12,58)	0.560 (14,22)
68	0.938 (23,83)	0.962 (24,43)	0.850 (21,6)	0.858 (21,8)
84	1.141 (28,99)	1.165 (29,59)	1.047 (26,6)	1.063 (27,0)

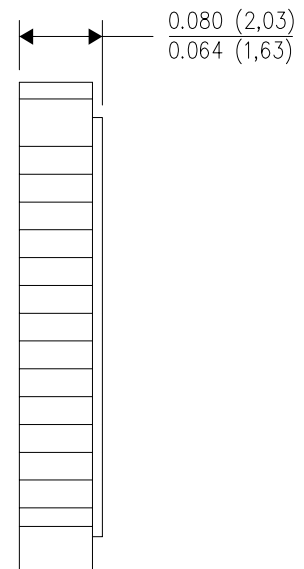
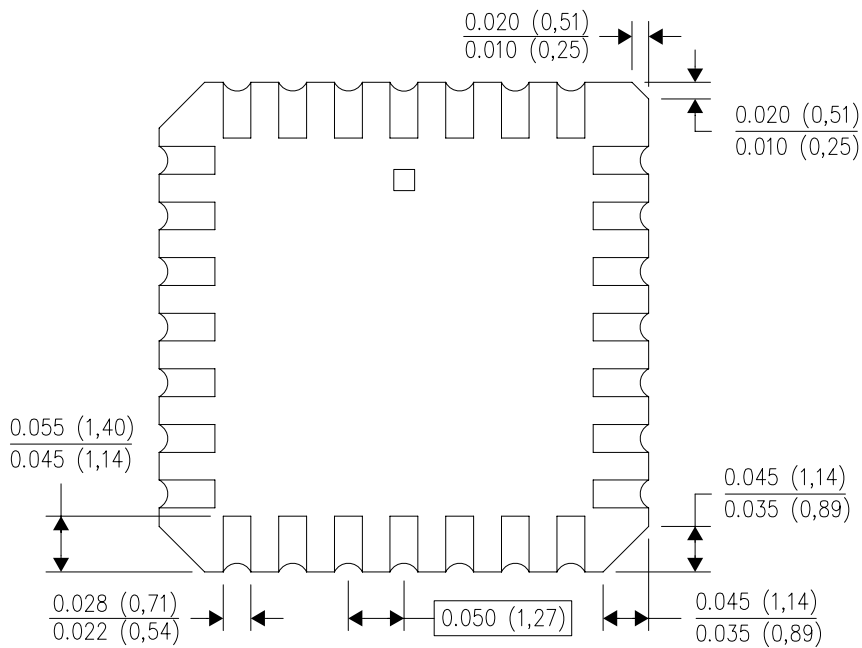

4040140/D 01/11

- NOTES:
- A. All linear dimensions are in inches (millimeters).
 - B. This drawing is subject to change without notice.
 - C. This package can be hermetically sealed with a metal lid.
 - D. Falls within JEDEC MS-004

D (R-PDSO-G16)

PLASTIC SMALL OUTLINE

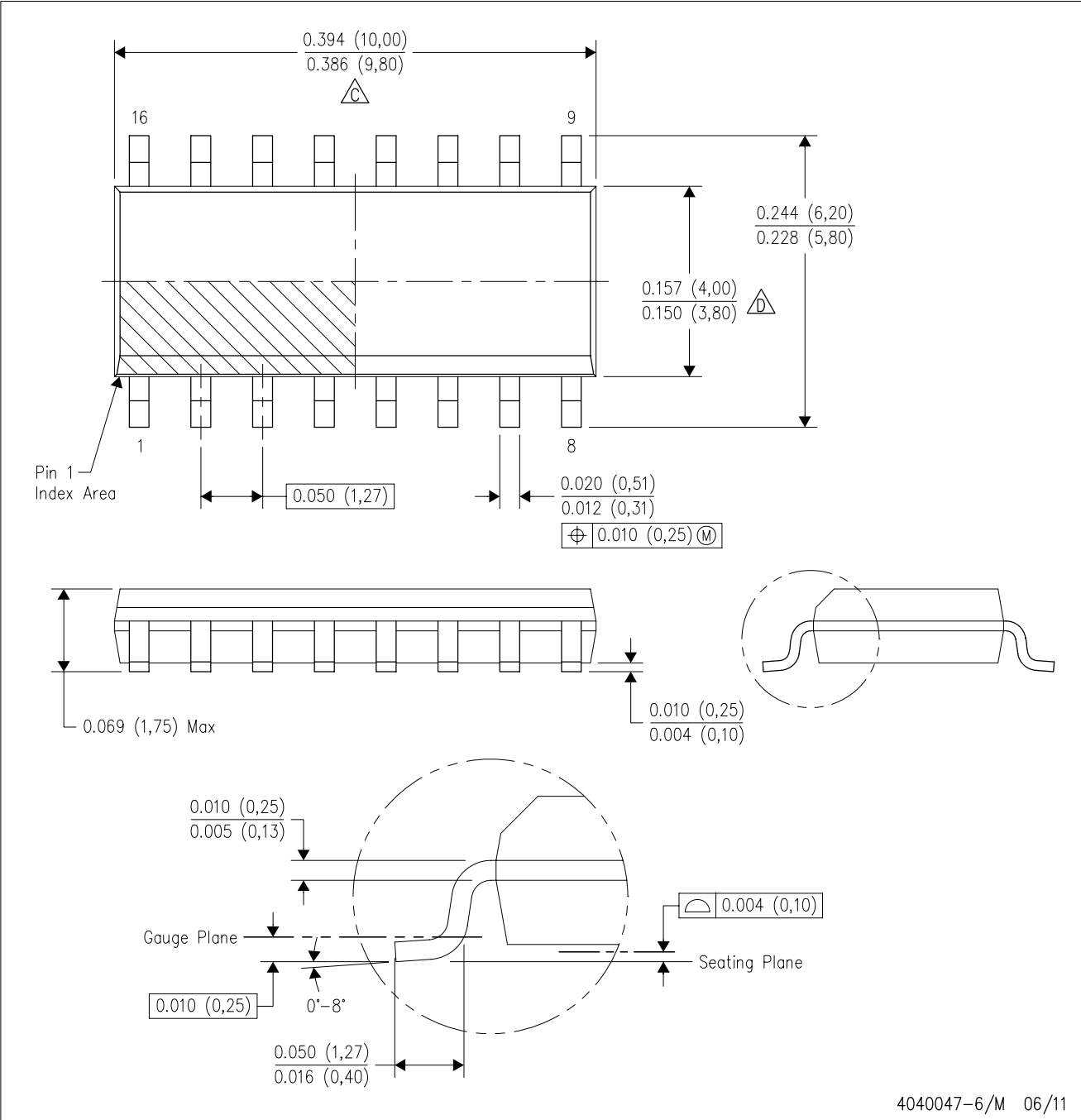

4040047-6/M 06/11

- NOTES:
- A. All linear dimensions are in inches (millimeters).
 - B. This drawing is subject to change without notice.
 - C. Body length does not include mold flash, protrusions, or gate burrs. Mold flash, protrusions, or gate burrs shall not exceed 0.006 (0,15) each side.
 - D. Body width does not include interlead flash. Interlead flash shall not exceed 0.017 (0,43) each side.
 - E. Reference JEDEC MS-012 variation AC.

D (R-PDSO-G16)

PLASTIC SMALL OUTLINE

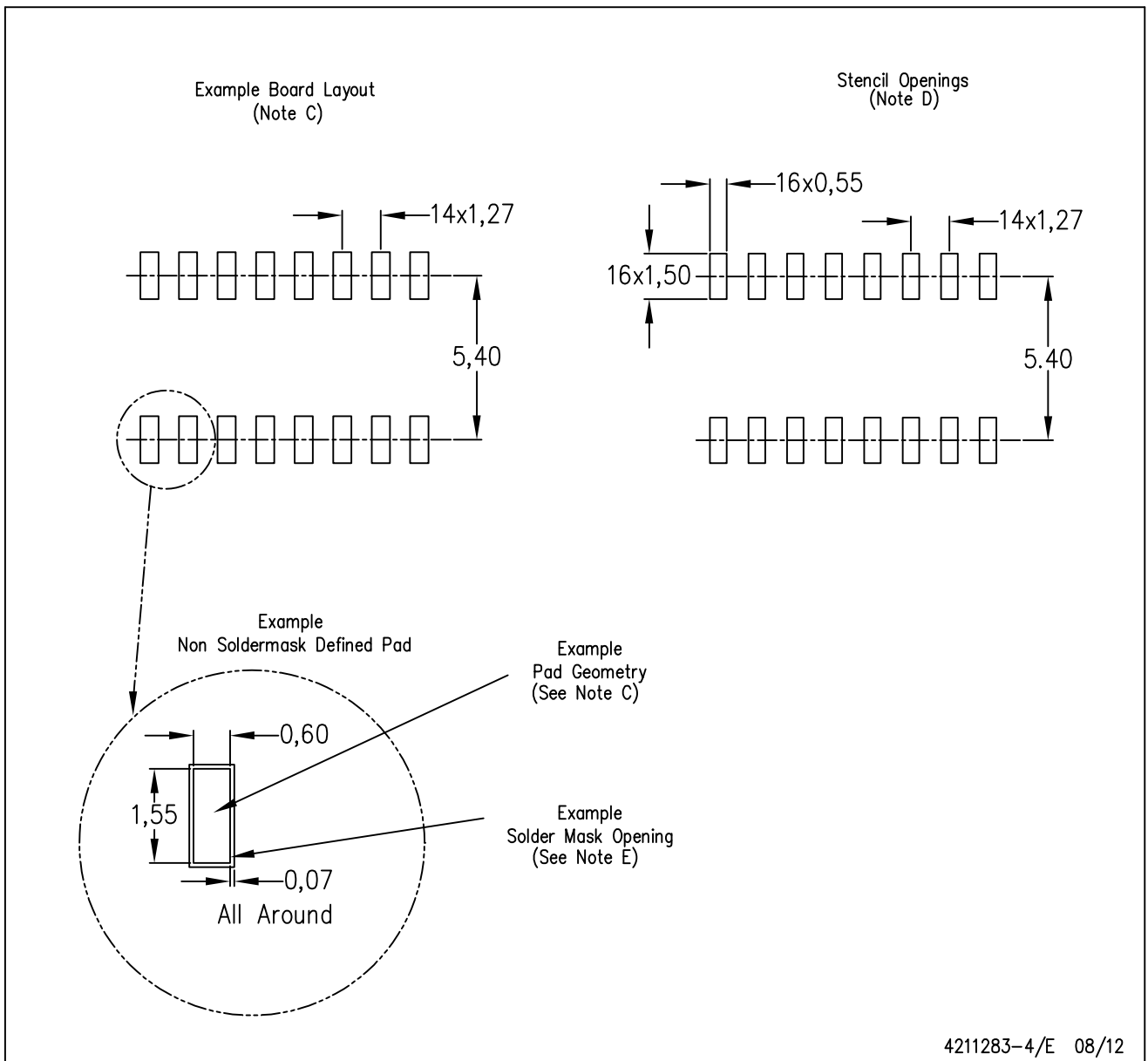

- NOTES:
- All linear dimensions are in millimeters.
 - This drawing is subject to change without notice.
 - Publication IPC-7351 is recommended for alternate designs.
 - Laser cutting apertures with trapezoidal walls and also rounding corners will offer better paste release. Customers should contact their board assembly site for stencil design recommendations. Refer to IPC-7525 for other stencil recommendations.
 - Customers should contact their board fabrication site for solder mask tolerances between and around signal pads.

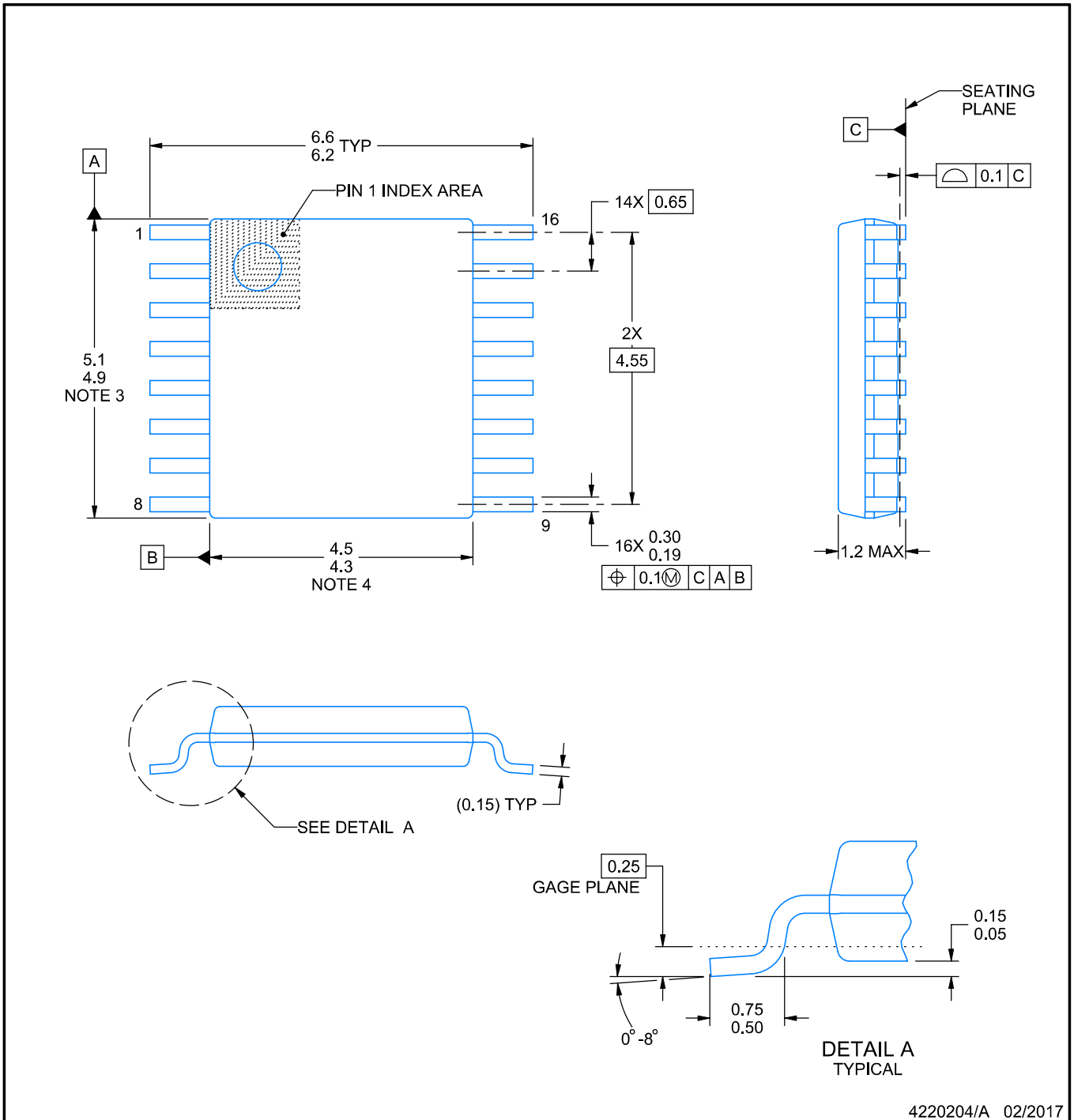

4220204/A 02/2017

NOTES:

1. All linear dimensions are in millimeters. Any dimensions in parenthesis are for reference only. Dimensioning and tolerancing per ASME Y14.5M.
2. This drawing is subject to change without notice.
3. This dimension does not include mold flash, protrusions, or gate burrs. Mold flash, protrusions, or gate burrs shall not exceed 0.15 mm per side.
4. This dimension does not include interlead flash. Interlead flash shall not exceed 0.25 mm per side.
5. Reference JEDEC registration MO-153.

EXAMPLE BOARD LAYOUT

PW0016A

TSSOP - 1.2 mm max height

SMALL OUTLINE PACKAGE

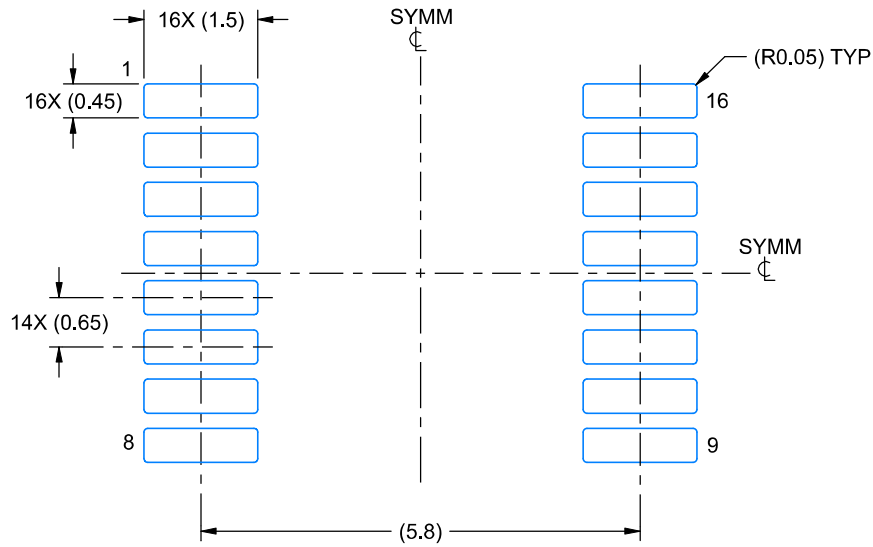

LAND PATTERN EXAMPLE
EXPOSED METAL SHOWN
SCALE: 10X

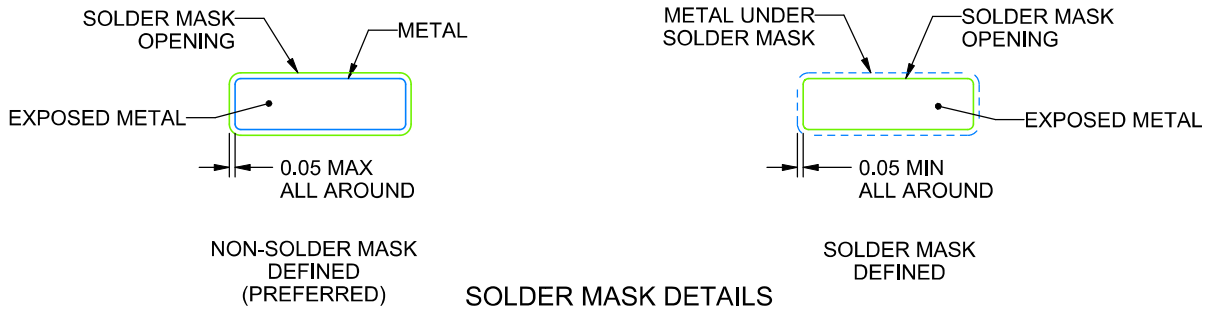

4220204/A 02/2017

NOTES: (continued)

- 6. Publication IPC-7351 may have alternate designs.
- 7. Solder mask tolerances between and around signal pads can vary based on board fabrication site.

EXAMPLE STENCIL DESIGN

PW0016A

TSSOP - 1.2 mm max height

SMALL OUTLINE PACKAGE

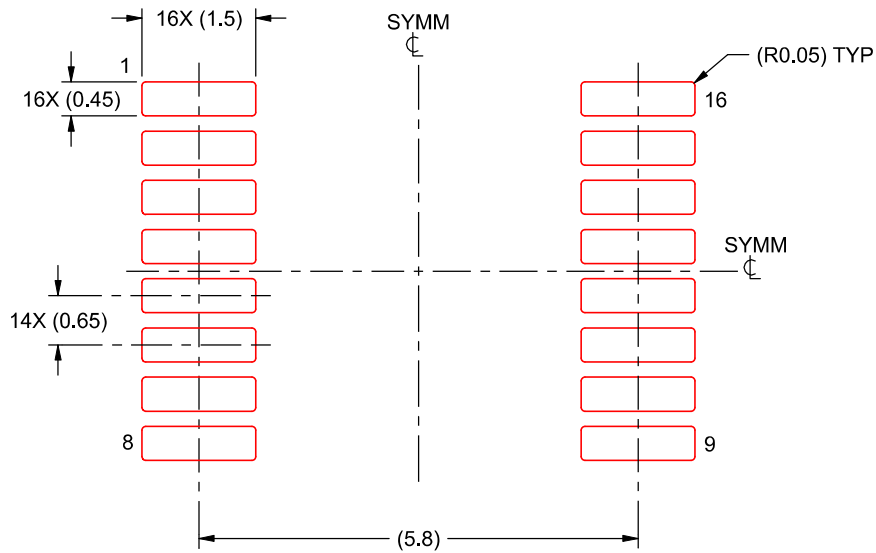

SOLDER PASTE EXAMPLE
BASED ON 0.125 mm THICK STENCIL
SCALE: 10X

4220204/A 02/2017

NOTES: (continued)

8. Laser cutting apertures with trapezoidal walls and rounded corners may offer better paste release. IPC-7525 may have alternate design recommendations.
9. Board assembly site may have different recommendations for stencil design.

MECHANICAL DATA

NS (R-PDSO-G**)

PLASTIC SMALL-OUTLINE PACKAGE

14-PINS SHOWN

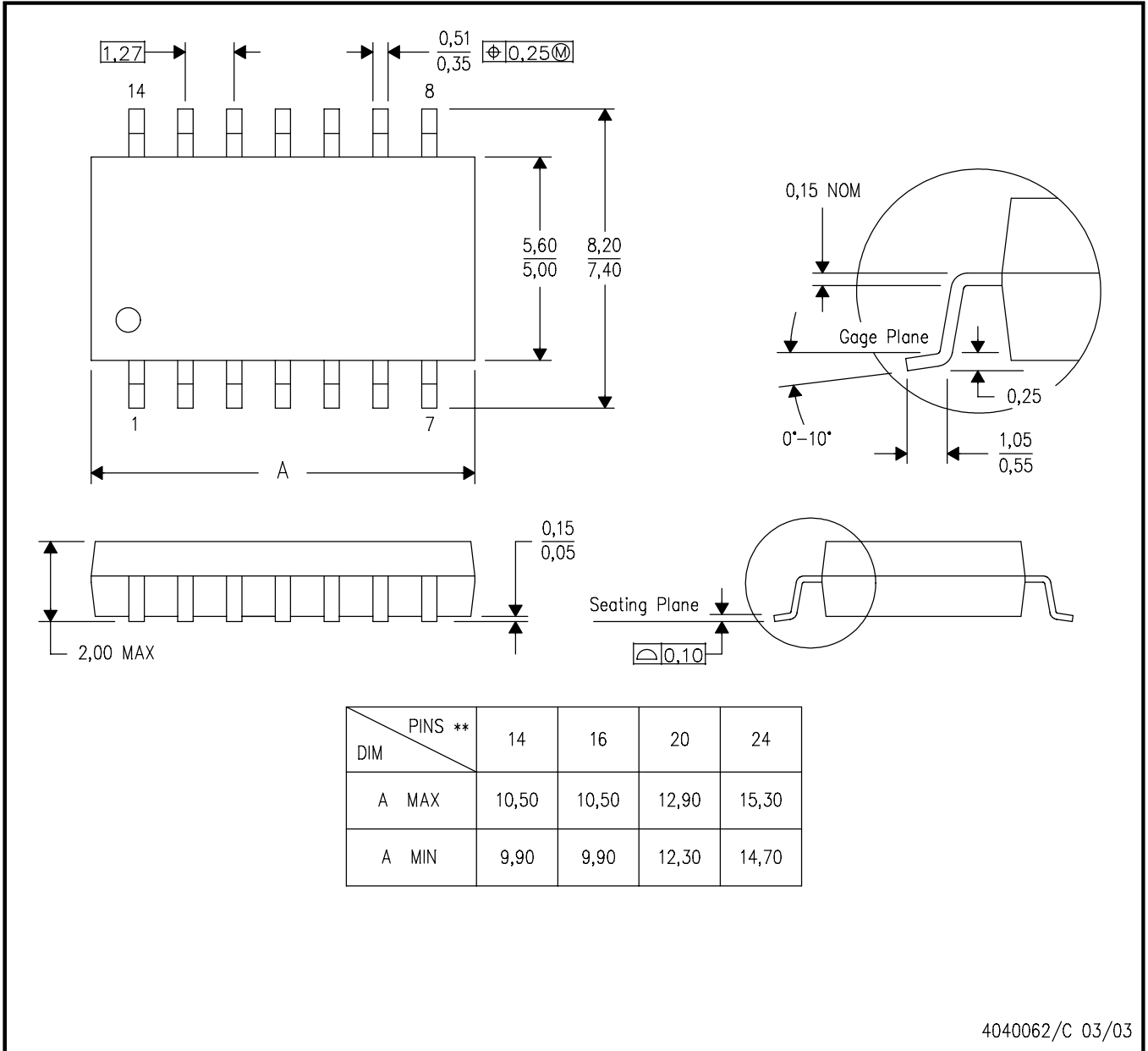

4040062/C 03/03

- NOTES:
- A. All linear dimensions are in millimeters.
 - B. This drawing is subject to change without notice.
 - C. Body dimensions do not include mold flash or protrusion, not to exceed 0,15.

J (R-GDIP-T**)

14 LEADS SHOWN

CERAMIC DUAL IN-LINE PACKAGE

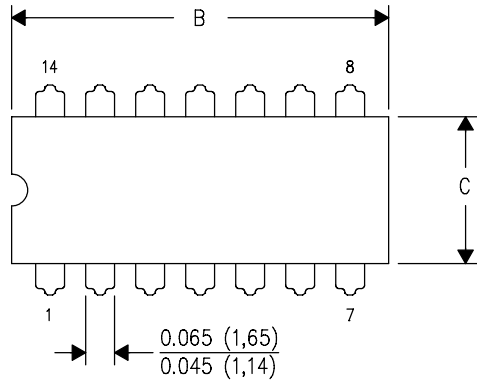

PINS **	14	16	18	20
DIM				
A	0.300 (7,62) BSC	0.300 (7,62) BSC	0.300 (7,62) BSC	0.300 (7,62) BSC
B MAX	0.785 (19,94)	.840 (21,34)	0.960 (24,38)	1.060 (26,92)
B MIN	—	—	—	—
C MAX	0.300 (7,62)	0.300 (7,62)	0.310 (7,87)	0.300 (7,62)
C MIN	0.245 (6,22)	0.245 (6,22)	0.220 (5,59)	0.245 (6,22)

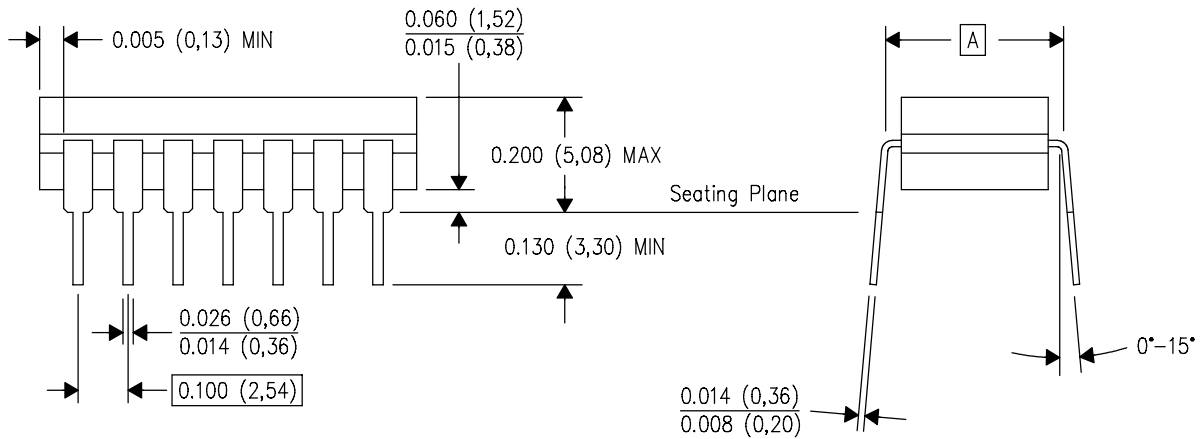

4040083/F 03/03

- NOTES:
- A. All linear dimensions are in inches (millimeters).
 - B. This drawing is subject to change without notice.
 - C. This package is hermetically sealed with a ceramic lid using glass frit.
 - D. Index point is provided on cap for terminal identification only on press ceramic glass frit seal only.
 - E. Falls within MIL STD 1835 GDIP1-T14, GDIP1-T16, GDIP1-T18 and GDIP1-T20.

N (R-PDIP-T**)

PLASTIC DUAL-IN-LINE PACKAGE

16 PINS SHOWN

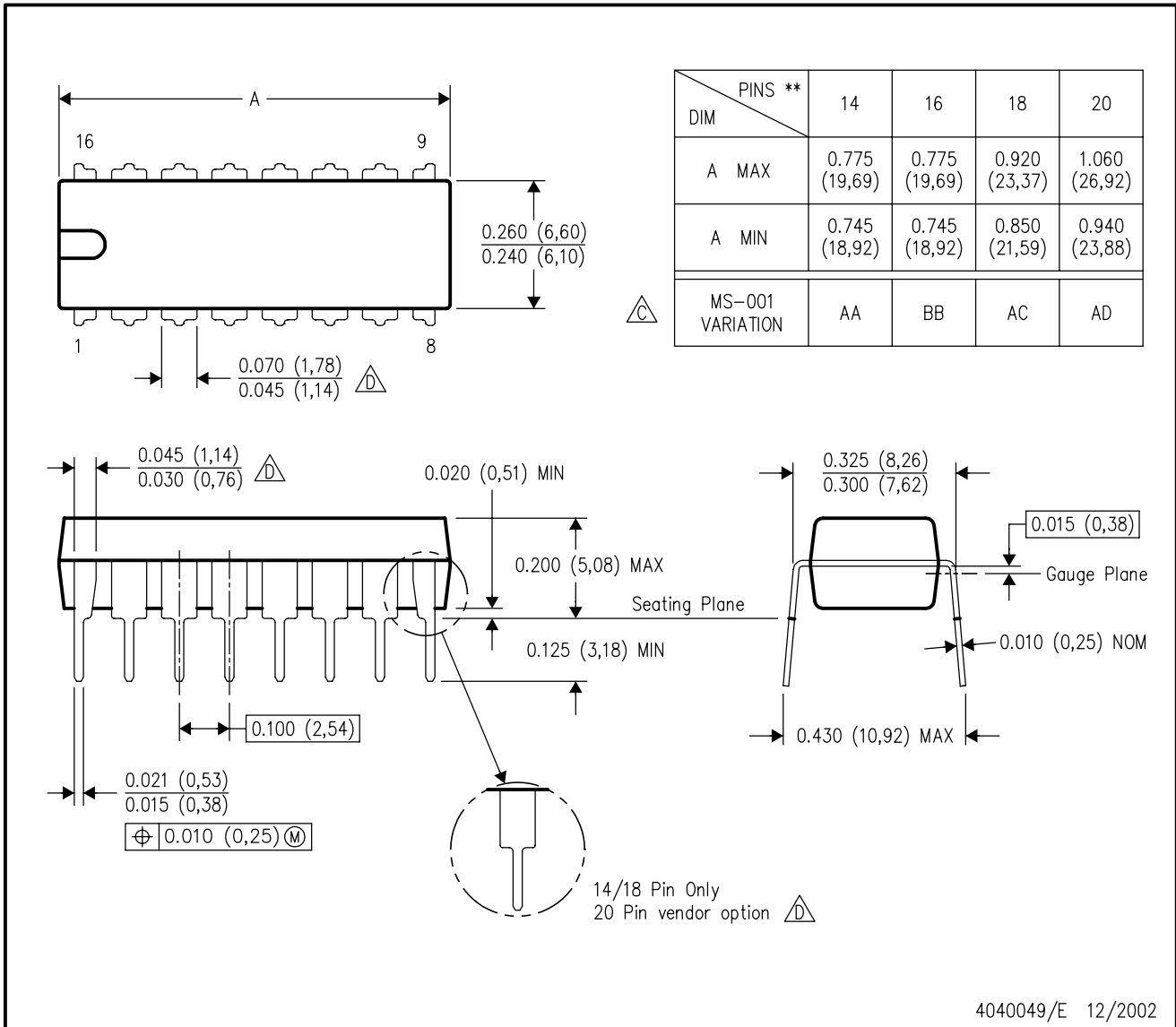

- NOTES:
- A. All linear dimensions are in inches (millimeters).
 - B. This drawing is subject to change without notice.
 - Falls within JEDEC MS-001, except 18 and 20 pin minimum body length (Dim A).
 - The 20 pin end lead shoulder width is a vendor option, either half or full width.

IMPORTANT NOTICE AND DISCLAIMER

TI PROVIDES TECHNICAL AND RELIABILITY DATA (INCLUDING DATASHEETS), DESIGN RESOURCES (INCLUDING REFERENCE DESIGNS), APPLICATION OR OTHER DESIGN ADVICE, WEB TOOLS, SAFETY INFORMATION, AND OTHER RESOURCES "AS IS" AND WITH ALL FAULTS, AND DISCLAIMS ALL WARRANTIES, EXPRESS AND IMPLIED, INCLUDING WITHOUT LIMITATION ANY IMPLIED WARRANTIES OF MERCHANTABILITY, FITNESS FOR A PARTICULAR PURPOSE OR NON-INFRINGEMENT OF THIRD PARTY INTELLECTUAL PROPERTY RIGHTS.

These resources are intended for skilled developers designing with TI products. You are solely responsible for (1) selecting the appropriate TI products for your application, (2) designing, validating and testing your application, and (3) ensuring your application meets applicable standards, and any other safety, security, or other requirements. These resources are subject to change without notice. TI grants you permission to use these resources only for development of an application that uses the TI products described in the resource. Other reproduction and display of these resources is prohibited. No license is granted to any other TI intellectual property right or to any third party intellectual property right. TI disclaims responsibility for, and you will fully indemnify TI and its representatives against, any claims, damages, costs, losses, and liabilities arising out of your use of these resources.

TI's products are provided subject to TI's Terms of Sale (<https://www.ti.com/legal/termsofsale.html>) or other applicable terms available either on [ti.com](https://www.ti.com) or provided in conjunction with such TI products. TI's provision of these resources does not expand or otherwise alter TI's applicable warranties or warranty disclaimers for TI products.

Mailing Address: Texas Instruments, Post Office Box 655303, Dallas, Texas 75265
Copyright © 2021, Texas Instruments Incorporated