



GlobalTech Display

A Professional LCD Displays Provider

TFT LCD Display Specification

PN: GLT0701024600IS2-CTP

Overview:

- 7.0" Diagonal
- IPS, Full View Angle
- Driver: EK79001+EK73215
- 16.7M Colors
- 1100 Nits
- 1024 x 600 Pixels
- Transmissive/Normally Black
- LVDS Interface
- Capacitive Touch Panel
- RoHS Compliant

9825 Widmer Road, Lenexa, KS 66215, USA | Tel: 913-828-5685 Fax: 913-273-4397

Email: sales@gtdisplays.com Website: www.gtdisplays.com

Table of Contents

1. Record of Revision	2
2. General Specifications.....	3
3. Input / Output Terminals	4
4. Absolute Maximum Rating.....	6
5. Electrical Characteristics.....	6
6. Interface Timing.....	8
7. Optical Characteristics.....	14
8. Environmental / Reliability Tests.....	17
9. Mechanical Drawing	18
10. Packing.....	19
11. TFT- LCD Module Inspection Criteria	20
12. Precautions for Use of LCD modules.....	26

1. Record of Revision

Rev	Issued Date	Description	Editor
1.0	2021/02/26	First Release.	ZWF

2. General Specifications

	Feature	Spec
Characteristics	Size	7 inch
	Resolution	1024(horizontal) x 600(Vertical)
	Interface	LVDS
	Connect type	Connector
	Display Colors	16.7M
	Technology type	a-Si
	Pixel pitch (mm)	0.150 x 0.143
	Pixel Configuration	R.G.B.-Stripe
	Display Mode	Normally Black
	LCD Driver IC	EK79001HN + EK73215BCGA
	CTP Driver IC	GT911
	Viewing Direction	Full view
Mechanical	LCM (W x H x D) (mm)	175.80 x 109.24 x 7.67
	Active Area(mm)	154.21 x 85.92
	With /Without TSP	With CTP
	Weight (g)	~225g
	LED Numbers	30 LEDs

Note 1: Requirements on Environmental Protection: RoHs

Note 2: LCM weight tolerance: +/- 5%

3. Input / Output Terminals

3.1 LCD Pin Assignment

No.	Symbol	Description
1	VCOM	Common Voltage
2	VDD	Power Voltage for digital circuit
3	VDD	Power Voltage for digital circuit
4	NC	No connection
5	RESET	Global reset pin
6	STBYB	Standby mode Normally pulled high STBYB=1,normal operation STBYB=0,timing controller, source Driver will turn off, all output are High-Z
7	GND	Ground
8	RXIN0-	-LVDS differential data input
9	RXIN0+	+LVDS differential data input
10	GND	Ground
11	RXIN1-	-LVDS differential data input
12	RXIN1+	+LVDS differential data input
13	GND	Ground
14	RXIN2-	-LVDS differential data input
15	RXIN2+	+LVDS differential data input
16	GND	Ground
17	RXCLKIN-	-LVDS differential clock input
18	RXCLKIN+	+LVDS differential clock input
19	GND	Ground
20	RXIN3-	-LVDS differential data input
21	RXIN3+	+LVDS differential data input
22	GND	Ground
23	NC	No connection
24	NC	No connection
25	GND	Ground
26	NC	No connection
27	DIMO	Backlight CABC controller signal output
28	SELB	6bit/8bit mode select (Note 1)
29	AVDD	Power for Analog Circuit
30	GND	Ground
31	LED-	LED Cathode

32	LED-	LED Cathode
33	L/R	Horizontal inversion (Note 2)
34	U/D	Vertical inversion (Note 2)
35	VGL	Gate OFF Voltage Power supply
36	NC	No connection
37	NC	No connection
38	VGH	Gate ON Voltage
39	LED+	LED Anode
40	LED+	LED Anode

Note 1: if LVDS input data is 6bit, SELB must be set to high;
if LVDS input data is 8bit, SELB must be set to low;

Note 2: when L/R=0 set right to left scan direction
when L/R=1 set left to right scan direction
when U/D=0 set top to bottom scan direction
when U/D=1 set bottom to top scan direction

3.2 CTP Pin Assignment

Pin	Signal	Description
1	GND	Ground
2	VDD	Power supply
3	SDA	I2C data input and output
4	SCL	I2C clock input
5	RST	Reset Pin for CTP
6	INT	Interrupt request to the host
7	Test-NC	No connection
8	VSS-GND	Ground

4. Absolute Maximum Rating

Item	Symbol	MIN	TYP	MAX	Unit	Remark
Supply Voltage	VDD	-0.3	-	5	V	-
Operating Temperature	TOPR	-20	-	70	°C	-
Storage Temperature	TSTG	-30	-	80	°C	

5. Electrical Characteristics

5.1 Driving TFT LCD Panel

Item	Symbol	MIN	TYP	MAX	Unit	Remark
Power supply for LCD	VDD	3.0	3.3	3.6	V	
	AVDD	9.0	9.8	10.5	V	
	VGH	16.0	18.0	20	V	
	VGL	-7.5	-6.0	-5.0	V	
	VCOM	2.9	3.25	3.5	V	

5.2 CTP Electrical Characteristics

FPC Design	Item	Description	Remark
COF	IC solution on TP Model	GT911	
	Touch Count Max	5 point	
	Display Resolution	1024 x 600	
	Interface Type	I2C	
	I2C Slave Address	0x28	
	Origin of Coordinate	Top left corner	

Parameter	Min	TYP	Max	Unit
Interface Signal Voltage	-	2.8	-	V
Power Voltage	VDD	3.3	-	V

5.3 LED Driving Conditions

Item	Symbol	MIN	TYP	MAX	Unit	Remark
Forward Current	I_F	-	300	-	mA	
Forward Voltage	V_F	8.1	-	10.2	V	
Backlight Power consumption	W_{BL}	2.43	-	3.06	W	
LED Lifetime		-	50000	-	Hrs	

Note 1: Each LED: $I_F = 30 \text{ mA}$, $V_F = 2.8 \sim 3.4 \text{ V}$.

Note 2: Optical performance should be evaluated at $T_a = 25^\circ\text{C}$ only.

Note 3: If LED is driven by high current, high ambient temperature & humidity condition. The life Time of LED will be reduced. Operating life means brightness goes down to 50% initial brightness. Typical operating life time is estimated data.

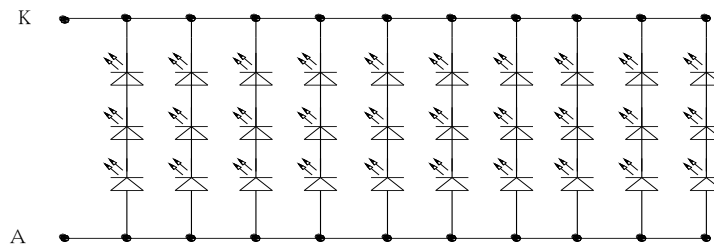
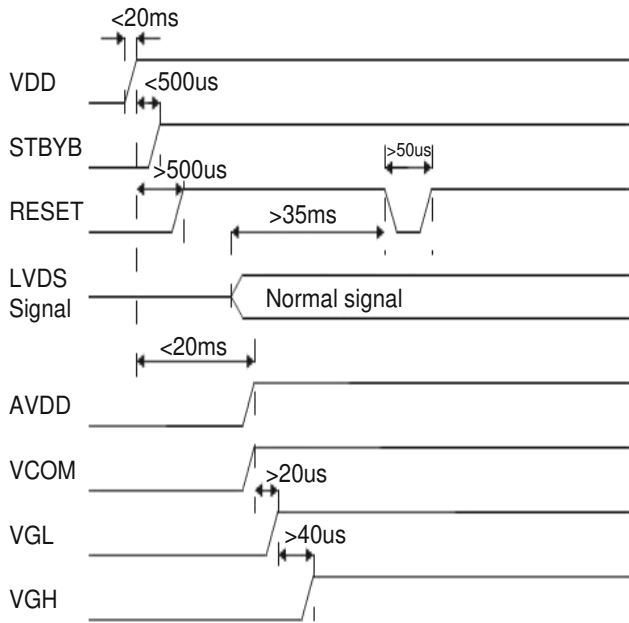

Figure: LED connection of backlight (Constant Current)

6. Interface Timing

6.1 Power sequence

a. Power on



b. Power off

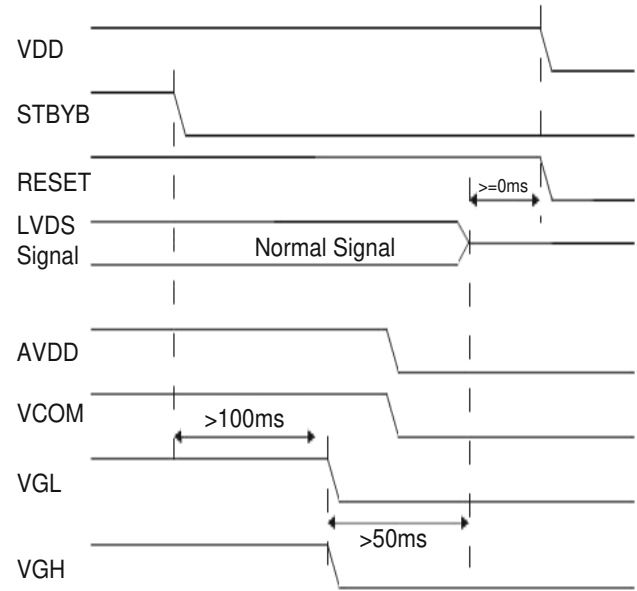

6.2 Timing Characteristics

Parameter	Symbol	Condition	Min.	Typ.	Max.	Unit
Clock Frequency	RxFCLK		20	-	71	MHz
Input data skew margin	T _{RSKM}	V _{ID} =400mV R _{xVCM} =1.2V R _x FCLK=71MHz	500			ps
Clock High Time	T _{LVCH}			4/(7* R _x FCLK)		ns
						ns
Clock Low Time	T _{LVCL}			3/(7* R _x FCLK)		ns
PLL wake-up-time	T _{enPLL}				150	us

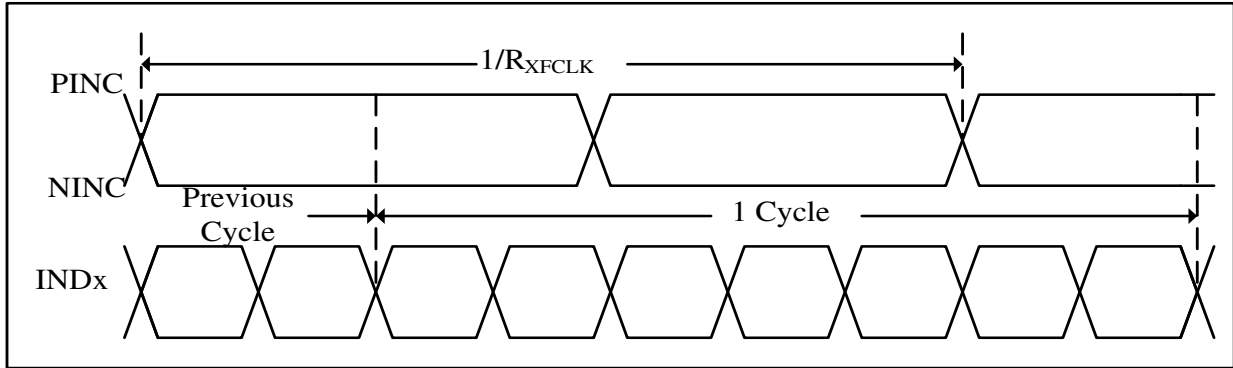

LVDS timing(1)

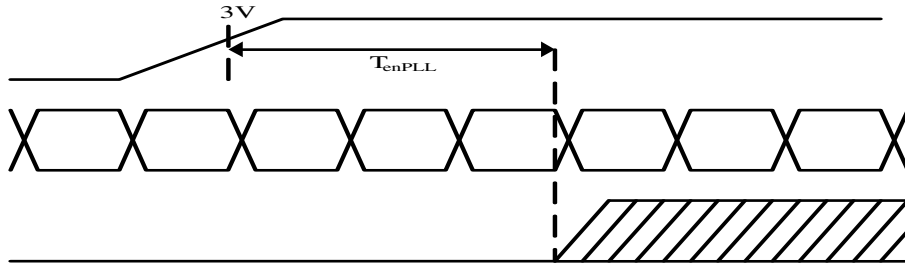

LVDS timing(2)

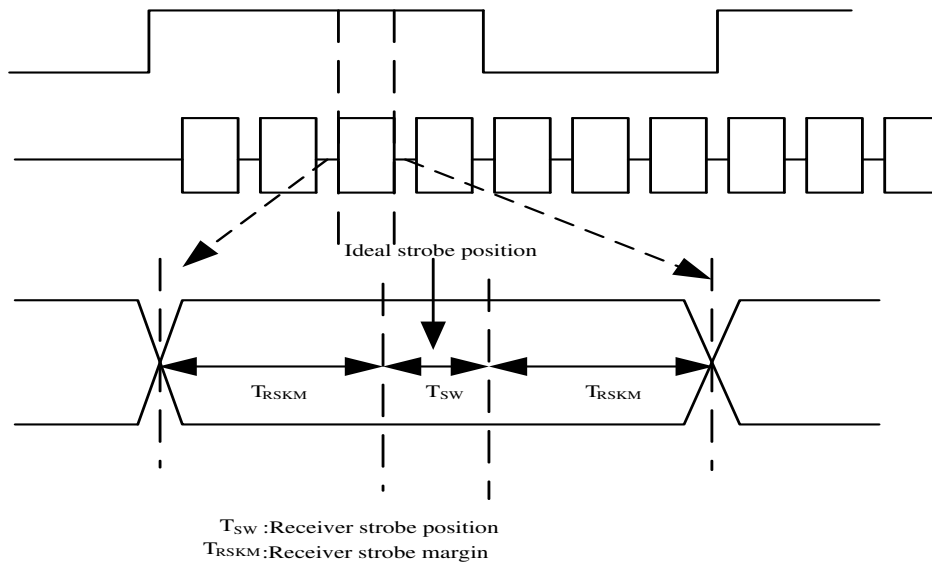

LVDS timing(3)

LVDS DC characteristic

Parameter	Symbol	Min.	Typ.	Max.	Unit	Condition
Differential input high threshold voltage	R_{xVTH}			+0.1V	V	$R_{xVCM}=1.2V$
Differential input low threshold voltage	R_{xVTL}	-0.1			V	
Input voltage range (single-end)	R_{xVIN}	0		2.4	V	
Differential input common mode voltage	R_{xVCM}	$ V_{ID} /2$		$2.4 - V_{ID} /2$	V	
Differential input voltage	$ V_{ID} $	0.2		0.6	V	
Differential input leakage current	R_{xVTH}	-10		+10	V	
LVDS Digital Operating Current	I_{ddlvds}	-	40(TBD)	50	mA	Fclk=65Mhz VDD=3.3V
LVDS Digital Standby Current	I_{stlvds}	-	10(TBD)	50	uA	Clock & all functions are stop

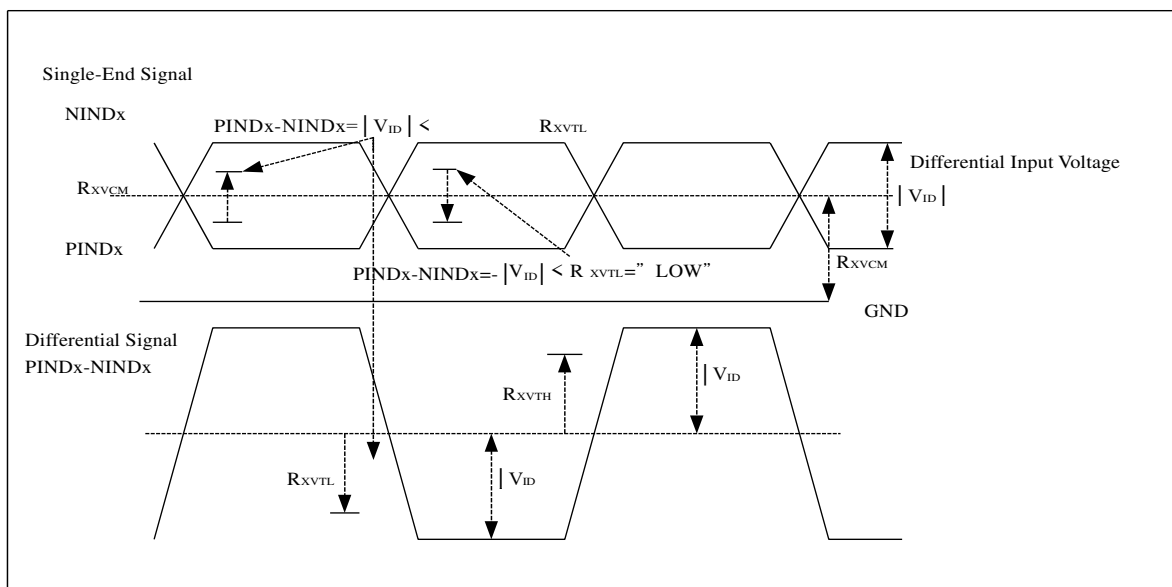

LVDS DC Characteristic

DE mode					
Parameter	Symbol	Value			Unit
		Min.	Typ.	Max.	
DCLK frequency @Frame rate=60hz	fclk	40.8	51.2	67.2	Mhz
Horizontal display area	thd	1024			DCLK
HSYNC period time	th	1114	1344	1400	DCLK
HSYNC blanking	thb+thfp	90	320	376	DCLK
Vertical display area	tvd	600			H
VSYNC period time	tv	610	635	800	H
VSYNC blanking	tvb+tvfp	10	35	200	H

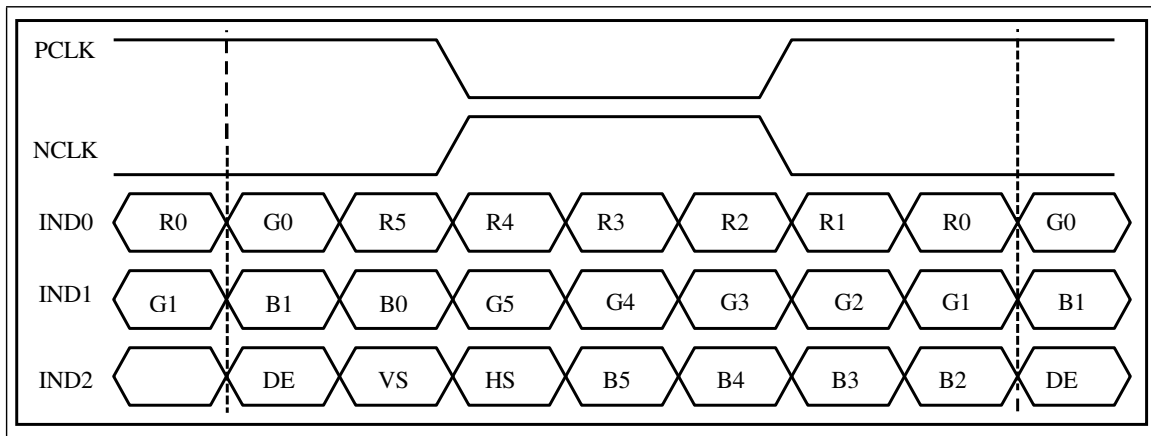

6-bit LVDS Input Timing chart

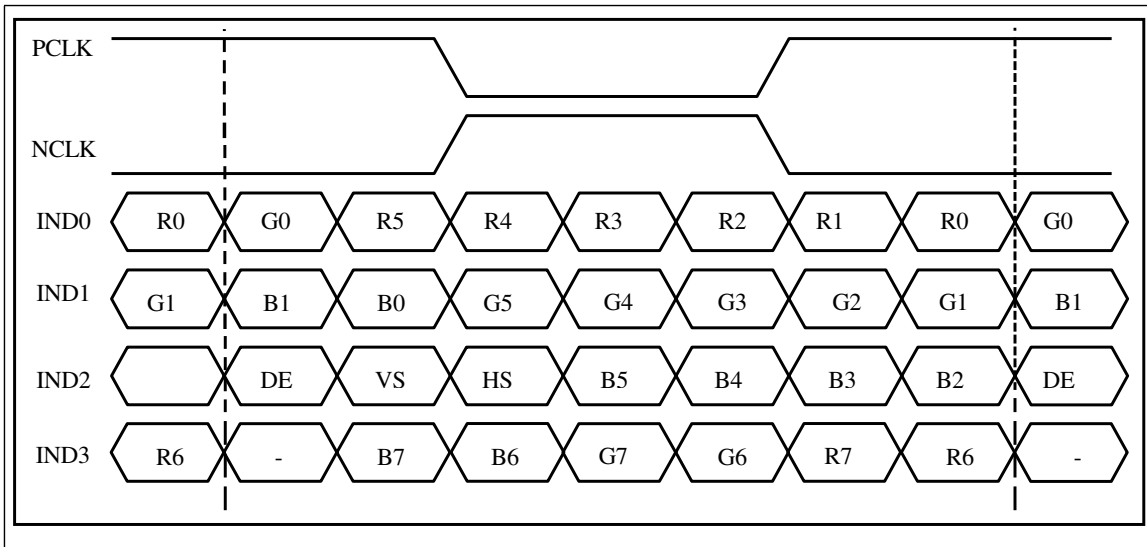

8-bit LVDS Input Timing chart

6.3 Capacitive touch panel Specification

GT911 provides standard I²C interface for communication. In the system, GT911 always works in slave mode, all communications are initiated by master, and the baud rate can be up to 400K bps. The definition of I²C timing is as following:

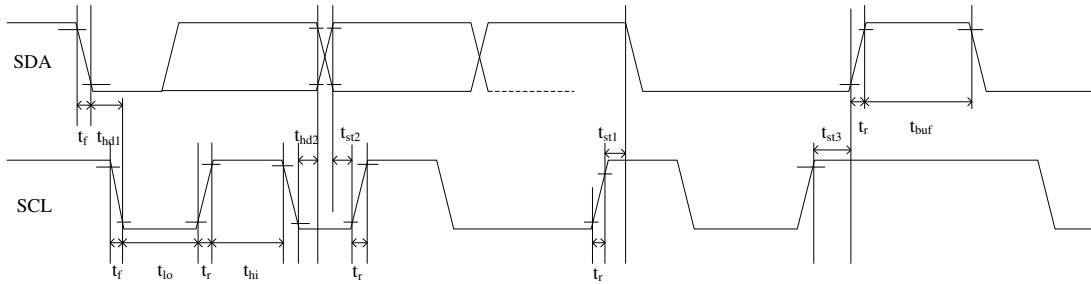

Test condition1: 1.8V communication interface, 400Kbps, pull up resistor is 2K ohm

Parameter	Symbol	MIN.	Max.	Unit
SCL low period	t_{lo}	1.3	-	us
SCL high period	t_{hi}	0.6	-	us
SCL setup time for START condition	t_{st1}	0.6	-	us
SCL setup time for STOP condition	t_{st3}	0.6	-	us
SCL hold time for START condition	t_{hd1}	0.6	-	us
SDA setup time	t_{st2}	0.1	-	us
SDA hold time	t_{hd2}	0	-	us

Test condition2: 3.3V communication interface, 400Kbps, pull up resistor is 2K ohm

Parameter	Symbol	MIN.	Max.	Unit
SCL low period	t_{lo}	1.3	-	us
SCL high period	t_{hi}	0.6	-	us
SCL setup time for START condition	t_{st1}	0.6	-	us
SCL setup time for STOP condition	t_{st3}	0.6	-	us
SCL hold time for START condition	t_{hd1}	0.6	-	us
SDA setup time	t_{st2}	0.1	-	us
SDA hold time	t_{hd2}	0	-	us

a). Write Data to GT911

(ex: slave address is 0xBA/0xBB)

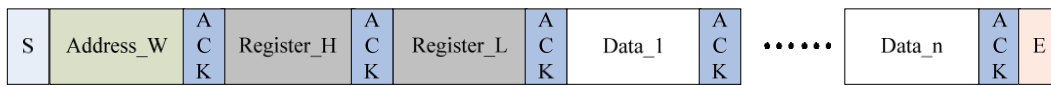

Write operations

Please check the above figure, master start the communication first, and then sends device address 0xBA preparing for a write operation.

After receiving ACK from GT911, master sends out 16-bit register address, and then the data word in 8-bit, which is going to be wrote into GT911.

The address pointer of GT911 will automatically increase one after one byte writing, so master can sequentially write in one operation. When operation finished, master stop the communication.

b). Read Data from GT911

(ex: slave address is 0xBA/0xBB)



Read operations

Please check the above figure, master start the communication first, and then sends device address 0xBA for a write operation.

After receiving ACK from GT911, master sends out 16-bit register address, to set the address pointer of GT911. After receiving ACK, master produce start signal once again & send device address 0xBB , then read data word from GT911 in 8-bit.

GT911 also supports sequential read operation, and the default setting is sequential read mode. Master shall send out ACK after every byte reading successfully but NACK after the last one. Then sends stop signal to finish the communication.

7. Optical Characteristics

Items	Symbol	Condition	Min.	Typ.	Max.	Unit	Remark	Note
Response time	Tr+Tf	-	-	30	40	ms	FIG.1	Note4
Contrast Ratio	CR		500	800	-	-	FIG.2	Note1
Surface luminance	LV	$\theta=0^\circ$	950	1100	-	cd/m2	FIG.2	Note2
Luminance uniformity	Yu	$\theta=0^\circ$	70	75	-	%	FIG.2	Note3
NTSC	-	$\theta=0^\circ$	-	50	-	%	FIG.2	Note5
Viewing angle	θ_T	Center CR \geq 10	-	85	-	deg	FIG.3	Note6
	θ_B		-	85	-	deg	FIG.3	
	θ_L		-	85	-	deg	FIG.3	
	θ_R		-	85	-	deg	FIG.3	
Chromaticity	Red	R_X	0.549	0.599	0.649	-	FIG.2 CIE1931	Note5
		R_Y	0.288	0.338	0.388	-		
	Green	G_X	0.249	0.299	0.349	-		
		G_Y	0.500	0.550	0.600	-		
	Blue	B_X	0.089	0.139	0.189	-		
		B_Y	0.081	0.131	0.183	-		
	White	W_X	0.258	0.308	0.358	-		
		W_Y	0.286	0.336	0.386	-		

Note1. Definition of contrast ratio

Contrast ratio (Cr) is defined mathematically by the following formula. For more information see FIG.2.

$$\text{Contrast ratio} = \frac{\text{Luminance measured when LCD on the "White" state}}{\text{Luminance measured when LCD on the "Black" state}}$$

For contrast ratio, Surface Luminance, Luminance uniformity and CIE, the testing data is based on TOPCON's BM-5 or BM-7 photo detector or compatible.

Note2. Definition of surface luminance

Surface luminance is the luminance with all pixels displaying white. For more information see FIG.2.

L_v = Average Surface Luminance with all white pixels (P1,P2,P3,, Pn)

Note3. Definition of luminance uniformity

The luminance uniformity in surface luminance is determined by measuring luminance at each test position 1 through n, and then dividing the maximum luminance of n points luminance by minimum luminance of n points luminance. For more information see FIG.2.

$$YU = \frac{\text{Minimum surface luminance with all white pixels (P1,P2,P3,.....,Pn)}}{\text{Maximum surface luminance with all white pixels (P1,P2,P3,.....,Pn)}}$$

Note4. Definition of response time

The response time is defined as the LCD optical switching time interval between “White” state and “Black” state. Rise time (T_r) is the time between photo detector output intensity changed from 90% to 10%. And fall time (T_f) is the time between photo detector output intensity changed from 10% to 90%.

For additional information see FIG1.

Note5. Definition of color chromaticity (CIE1931)

CIE (x,y) chromaticity, The x,y value is determined by screen active area center position P5. For more information see FIG.2.

Note6. Definition of viewing angle

Viewing angle is the angle at which the contrast ratio is greater than 10. Angles are determined for the horizontal or x axis and the vertical or y axis with respect to the z axis which is normal to the LCD surface. For more information see FIG.3.

For viewing angle and response time testing, the testing data is base on Autronic-Melchers’s ConoScope or DMS series Instruments or compatible.

FIG.1. The definition of response Time

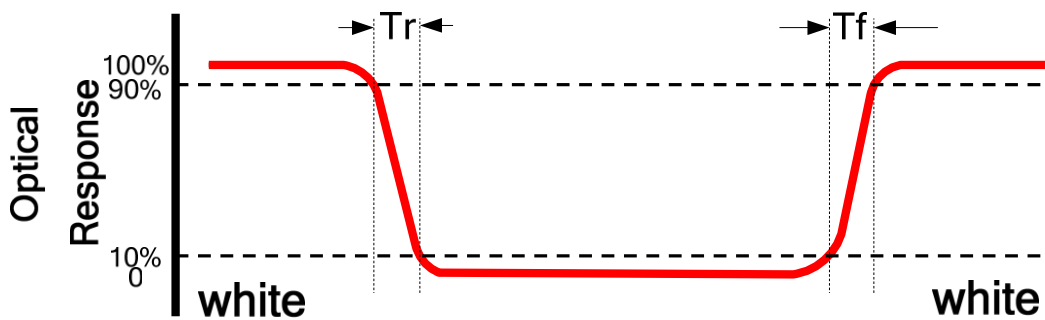

FIG.2. Measuring method for contrast ratio, surface luminance, luminance uniformity, CIE (x,y) chromaticity

Size: $S \leq 5"$ (see Figure a) A : 5 mm B : 5 mm

H,V: Active area

Light spot size $\phi=5\text{mm}$ (BM-5) or $\phi=7.7\text{mm}$ (BM-7) 50cm distance or compatible distance from the LCD surface to detector lens.

test spot position : see Figure a.

measurement instrument : TOPCON’s luminance meter BM-5 or BM-7 or compatible (see Figure c).

Size: $5" < S \leq 12.3"$ (see Figure b) H,V : Active area

Light spot size $\phi=5\text{mm}$ (BM-5) or $\phi=7.7\text{mm}$ (BM-7) 50cm distance or compatible distance from the LCD surface to detector lens.

test spot position : see Figure b.

measurement instrument : TOPCON’s luminance meter BM-5 or BM-7 or compatible (see Figure c).

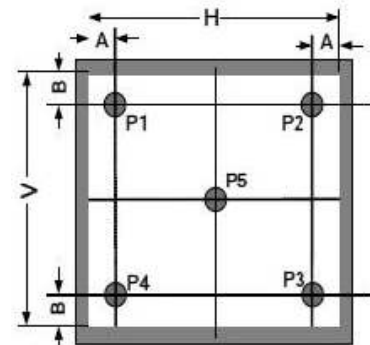

Figure a

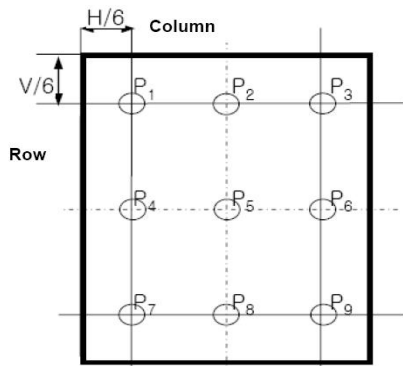

Figure b

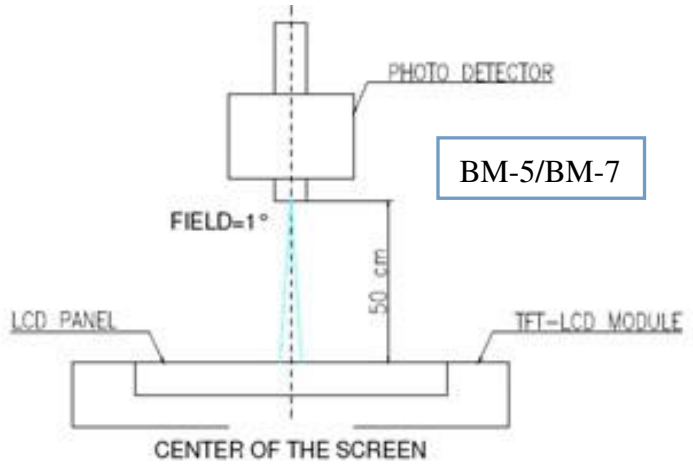
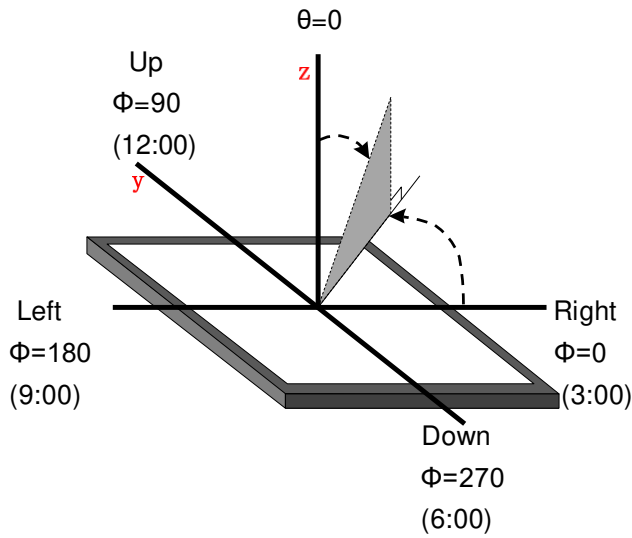

Figure c

FIG.3. The definition of viewing angle



8. Environmental / Reliability Tests

No	Test Item	Condition	Remarks
1	High Temperature Operation	Ts= +70°C, 96hrs	Note 1 IEC60068-2-2, GB2423. 2-89
2	Low Temperature Operation	Ta= -20°C, 96hrs	Note 2 IEC60068-2-1 GB2423.1-89
3	High Temperature Storage	Ta= +80°C, 96hrs	IEC60068-2-2 GB2423. 2-89
4	Low Temperature Storage	Ta= -30°C, 96hrs	IEC60068-2-1 GB/T2423.1-89
5	High Temperature & Humidity Storage	Ta= +60°C, 90% RH max, 96 hours	IEC60068-2-3 GB/T2423.3-2006
6	Thermal Shock (Non-operation)	-20°C 30 min ~ +60°C 30 min Change time: 5min, 30 Cycle	Start with cold temperature, end with high temperature IEC60068-2-14, GB2423.22-87
7	Electro Static Discharge (Operation)	C=150pF, R=330 Ω, 5 points/panel Air:±8KV, 5 times; Contact: ±4KV, 5 times; (Environment: 15°C ~ 35°C, 30% ~ 60%, 86Kpa ~ 106Kpa)	IEC61000-4-2 GB/T17626.2-1998
8	Vibration (Non-operation)	Frequency range: 10~55Hz, Stroke: 1.mm Sweep: 10Hz~55Hz~10Hz 2 hours for each direction of X .Y. Z. (package condition)	IEC60068-2-6 GB/T2423.5-1995
9	Shock (Non-operation)	60G 6ms, ± X, ±Y , ± Z 3 times for each direction	IEC60068-2-27 GB/T2423.5-1995
10	Package Drop Test	Height: 80 cm, 1 corner, 3 edges, 6 surfaces	IEC60068-2-32 GB/T2423.8-1995

- Note:
1. Ts is the temperature of panel's surface.
 2. Ta is the ambient temperature of sample.
 3. The size of sample is 5pcs.

9. Mechanical Drawing

CTP NOTES:

1. Surface type: G+G, Cover Glass+10CA+SENSOR+HPC, SENSOR: 0.55mm, Cover Glass: 1.1mm, SCA: 0.20mm, TP: 1.86mm±0.15;
2. IC: G1911(COP), (Channels 20*12);
3. Support touch: 5 points;
4. Surface hardness: ≥8H;
5. Working condition: DC3.3V, Interface I2C, IO: 3.3V;
6. Operation temperature: -20°C ~ +70°C, ≤50%/RH;
7. Storage temperature: -30°C ~ +80°C, ≤50%/RH;
8. Luminous stress: ≤85%;
9. All RoHS certified;
10. Reference Inclined: -0.2mm

LCM NOTES:

1. DISPLAY TYPE: 7.0 INCH TFT/Normally Black
2. VIEWING DIRECTION: UL/DL/R 55/65/85/85
3. BACKLIGHT: 30 CHIP WHITE LED, 3S1P
4. V_F = 8.1~10.2V; I_F = 300mA
5. OPERATING TEMP: -20°C ~ +70°C
6. STORAGE TEMP: -30°C ~ +80°C
7. LUMINOUS INTENSITY: 100cd/m² (TYP)
8. Reference dimension: Critical dimension
9. RoHS Compliant

LCM PIN

PIN	SYMBOL
1	VCOM
2	VDD
3	VDD
4	NC
5	RESET
6	STBYB
7	GND
8	RXIN0-
9	RXIN0+
10	GND
11	RXIN1-
12	RXIN1+
13	GND
14	RXIN2-
15	RXIN2+
16	GND
17	RXCCLKIN
18	RXCCLKIN+
19	GND
20	RXIN3-
21	RXIN3+
22	GND
23	NC
24	NC
25	GND
26	NC
27	DIM0
28	SELB/HSD
29	AVDD
30	GND
31	LED-
32	LED-
33	L/R
34	U/D
35	VGL
36	NC
37	NC
38	VGH
39	LED+
40	LED+

CIRCUIT DIAGRAM

GlobalTech Display

Material code:	10101453	PART NO.	GL107010246901S2-CTP
DWN	LL 2021.03.31	REV	1.0
CHNO	LI Huang 2021.03.31	TOLERANCE UNLESS SPECIFIED	±0.2
PROJECTION	5/8 ANGLE	UNIT	mm
		SCALE	1:1

10. Packing

Packing Method

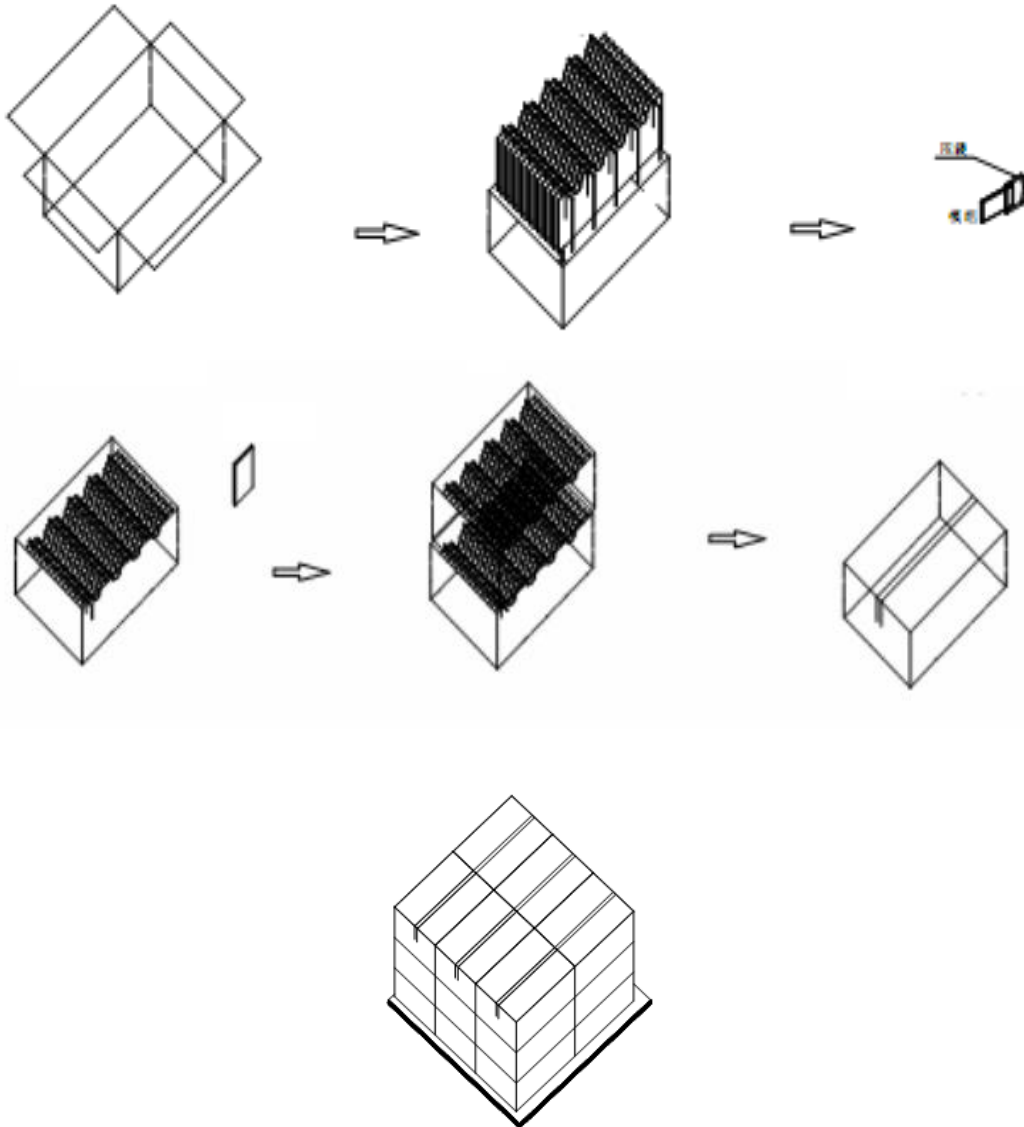

11. TFT-LCD Module Inspection Criteria

11.1 Objective

The TFT criterion is set to formalize the TFT quality standards with reference to customer for inspection.

11.2 Scope

The criterion is applicable to $5'' \leq S < 10''$ TFT products (Include TFT, TFT+RTP or TFT+CTP) manufactured by TFC.

11.3 Tools for Inspection

Tester, Calipers, Multi-meter, Anti-static wrist straps, Finger Cots, Desk Lamps, etc.

11.4 Sampling Plan and Reference Standards

11.4.1 Sampling plan:

Refer to GB/T2828.1-2012/ISO2859-1:1999 //MIL-STD-105E

AQL: level II; normal:

1) MA=0.40; 2) MI=0.65

11.4.2 IPC-A-610 Acceptability of Electronic Assemblies

11.5 Inspection Conditions and Inspection Reference

11.5.1 Cosmetic inspection with naked eyes:

- 1) Temperature: $23 \pm 5^\circ\text{C}$; relative humidity: 45~75%RH
- 2) Illumination: 500lux~1000lux
- 3) Distance: $30\text{cm} \pm 5$ from the inspector's naked eyes to the LCD panel.
- 4) View angle: within 45° from perpendicular to LCM surface (view direction and special parameters refer to production specification).

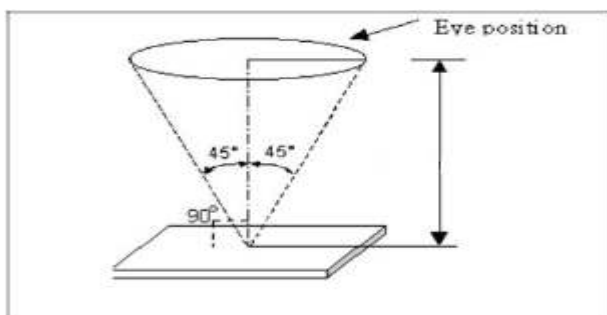

11.5.2 Definition

11.5.2.1 Area definition

A area: Active area (AA area)

B area: Viewing area (VA area)

C area: non-view area (out of B area)

11.5.2.2 Any cosmetic defect which do not affect product quality and customer assembling in C area, it's Acceptable. (The dimension is defined on the drawings)

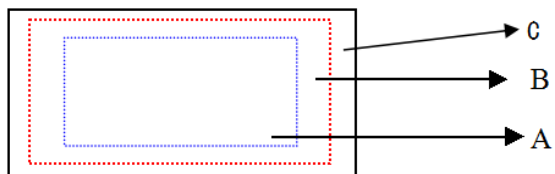

11.5.2.3 Test condition: refer to product specification

11.5.3 Defect type:

11.5.3.1 A area defect type:

Line defect (scratch, soft flocks, fiber), dot defect (white dot, black dot, same color dot, different color dot, bubble), stain, pin-hole, light leak, scratch.

11.5.3.2 B area defect type:

Broken, crack/chipping, FPC defect

11.5.4 Undefined items or other special items, refer to mutual agreement and limited sample by customer.

11.5.5 Test condition: refer to product specification.

11.6 Defects and Acceptance Standards

11.6.1 Appearance inspection

11.6.1.1 Dot/line defect

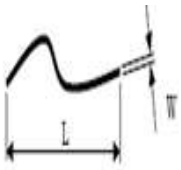
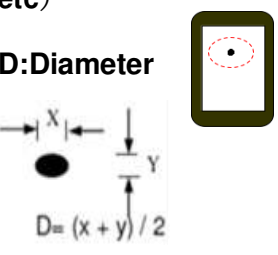
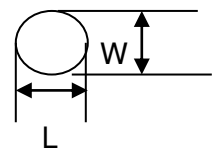
Defect	5≤S<10"	Accepted standard	MAX	MIN
S/C , line defect W:width L:length 	$W \leq 0.05\text{mm}$	Accept		√
	$0.05\text{mm} < W \leq 0.1\text{mm}$, $L \leq 8\text{mm}$ quantity ≤ 3 distance > 10mm	Accept		√
	$W > 0.1\text{mm}$ $L > 8\text{mm}$	Reject		√
Dot defect (black/white spot, foreign objects etc) D:Diameter 	$D \leq 0.15\text{mm}$	Accept		√
	$0.15\text{mm} < D \leq 0.30\text{mm}$ quantity ≤ 3 distance > 10mm	Accept		√
	$D > 0.30\text{mm}$	Reject		√
Polarizer with air bubble convex-concave dots or dent defect  $d = (w+l)/2$	$D \leq 0.20\text{mm}$	Accept		√
	$0.20\text{mm} < D \leq 0.5\text{mm}$ quantity ≤ 2	Accept		√
	$0.50\text{mm} < D \leq 0.8\text{mm}$ quantity ≤ 1	Accept		√
	$D > 0.8\text{mm}$	Reject		√

11.6.1.2 Chip and Crack

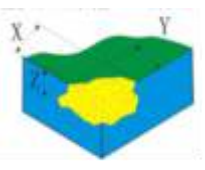
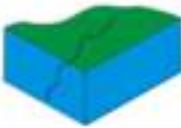
Defect	$5 \leq S < 10''$	Accepted standard	MAX	MIN
LENS chip 	$X \leq 0.3\text{mm}, Y \leq 0.4\text{mm},$ one side ≤ 1	Accept		√
	$X > 0.3\text{mm}, Y > 0.4\text{mm}$	Reject		√
Sensor chip	Not affect ITO line, not lengthen, function test is OK. And be non-visual after attaching Lens.	Accept		√
	Affect ITO line and be visual.	Reject		√
Glass crack 	Glass crack.	Reject		√



11.6.1.3 Attaching defect (kapton tape/protective film)

Defect	Description	Accepted standard	MAX	MIN
High temperature kapton tape	Kapton tape attached on FPC doesn't meet the criterion of drawing.	Reject		√
Protective film	Clean、 attaching flat、 no shifting	Accept		√

11.6.2 TFT defects and Inspection Criterion

11.6.2.1 Function items

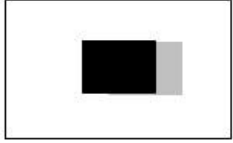
Defects	Inspection Criterion	Pictures	Inspection method/tools	Defect category
No display /function	shows no picture/display in normal connected situation. ->Rejected		Naked eyes/ testers	MA

Missing segment	Shows missing lines in normal display.->Rejected		Naked eyes/ testers	MA
Image retention (sticking)	The previous picture stays in the next picture. Disappear time <10s, OK; time>10s, NG		Naked eyes/ testers	MA
Flicker	Not accepted	/	Naked eyes/ testers	MA
Display abnormal	Not accepted		Naked eyes/ testers	MA
Display dim/bright	Refer to bright value definition	/	Naked eyes/ BM-7	MA
Contrast	Refer to SPEC	/	Naked eyes/ BM-7	MA
White/ black dot White/ black speckle	Refer to dot criterion	/	Naked eyes	MI

11.6.2.2 LCD pixel defect (defect category: MI)

Item	Inspection criterion
Size	$5 \leq S < 10''$
Pixel defect(RGB dot)	2
2 connected bright pixel dot	0
3 connected bright pixel dot or more	0
Bright pixel dot quantity	2
Random dark pixel dot quantity	3
2 connected pixel dark dot	1
3 connected pixel dark dot or more	0
Dark pixel dot quantity	4
Multi-bright pixel dot	ND 5% hidden, OK
Remark: 2 bright pixel dots distance $DS \geq 15\text{mm}$ 2 dark pixel dots distance $DS \geq 5\text{mm}$ 1) Bright pixel dot: Power on TFT and RGB dot in black display 2) Dark pixel dot: Power on TFT and gray or black dot in RGB display 3) Multi-bright pixel dot: Power on TFT and fluorescent tiny dot in black display(only visible in black display)	

11.7 Others

11.7.1 Some defect items are not defined in this document, obey to final negotiation between customer and manufacturer or sign limit sample.

11.7.2 If the final goods include FPC/PCB, inspection criterion refers to IPC-610, Level 2.

12. Precautions for Use of LCD modules

12.1 Handling Precautions

- 12.1.1. The display panel is made of glass. Do not subject it to a mechanical shock by dropping it from a high place, etc.
- 12.1.2. If the display panel is damaged and the liquid crystal substance inside it leaks out, be sure not to get any in your mouth, if the substance comes into contact with your skin or clothes, promptly wash it off using soap and water.
- 12.1.3. Do not apply excessive force to the display surface or the adjoining areas since this may cause the color tone to vary.
- 12.1.4. The polarizer covering the display surface of the LCD module is soft and easily scratched. Handle this polarizer carefully.
- 12.1.5. If the display surface is contaminated, breathe on the surface and gently wipe it with a soft dry cloth. If still not completely clear, moisten cloth with one of the following solvents:
 - Isopropyl alcohol
 - Ethyl alcoholSolvents other than those mentioned above may damage the polarizer. Especially, do not use the following:
 - Water
 - Ketene
- 12.1.6. Do not attempt to disassemble the LCD Module.
- 12.1.7. If the logic circuit power is off, do not apply the input signals.
- 12.1.8. To prevent destruction of the elements by static electricity, be careful to maintain an optimum work environment.
 - 12.1.8.1. Be sure to ground the body when handling the LCD Modules.
 - 12.1.8.2. Tools required for assembly, such as soldering irons, must be properly ground.
 - 12.1.8.3. To reduce the amount of static electricity generated, do not conduct assembly and other work under dry conditions.
 - 12.1.8.4. The LCD Module is coated with a film to protect the display surface. Be care when peeling off this protective film since static electricity may be generated.

12.2 Storage Precautions

- 12.2.1. When storing the LCD modules, avoid exposure to direct sunlight or to the light of fluorescent lamps.
- 12.2.2. The LCD modules should be stored under the storage temperature range. If the LCD modules will be stored for a long time, the recommend condition is:
Temperature: 0°C ~ 40°C Relative humidity: ≤80%
- 12.2.3. The LCD modules should be stored in the room without acid, alkali and harmful gas.

12.3 Transportation Precautions

The LCD modules should be no falling and violent shocking during transportation, and also should avoid excessive press, water, damp and sunshine.