

PROTECTION PRODUCTS

Description

The STF701 is a low pass T-filter with integrated TVS diodes. It is designed to provide bi-directional filtering of unwanted EMI/RFI signals and electrostatic discharge (ESD) protection in portable electronic equipment. Each device will provide filtering and protection for two I/O lines.

The STF701 is constructed using thin-film-on-silicon technology. The device has very low insertion loss in the pass band (to approximately 10MHz) and good attenuation at high frequencies (approximately 100MHz to 1GHz). Each line features two stages of TVS diode protection. The TVS diodes provide effective suppression of ESD voltages in excess of $\pm 15\text{kV}$ (air discharge) and $\pm 8\text{kV}$ (contact discharge) per IEC 61000-4-2, level 4.

The clamping characteristics of the device are optimized by the use of two TVS diodes. The TVS diodes serve a dual purpose of protecting the internal capacitor and the sensitive IC connected to the line. The voltage divider action of the circuit means the voltage across the protected IC will be very close to the breakdown voltage (V_{BR}) of the second TVS.

The small size and integrated feature of the STF701 minimizes required board space and increases system reliability. The STF701 is suitable for use in portable communications devices such as cellular handsets and accessory kits.

Features

- ◆ Bidirectional EMI/RFI filtering with integrated ESD protection
- ◆ ESD protection to **IEC 61000-4-2 (ESD) $\pm 15\text{kV}$ (air), $\pm 8\text{kV}$ (contact)**
IEC 61000-4-4 (EFT) 40A (5/50ns)
- ◆ Filtering and ESD protection for two data lines
- ◆ Low insertion loss to 10MHz
- ◆ Good attenuation of high frequency signals
- ◆ Low TVS operating voltage (5V)
- ◆ Low clamping voltage
- ◆ Low leakage current
- ◆ Thin-film-on-silicon technology

Mechanical Characteristics

- ◆ EIAJ SC70-5L package
- ◆ Molding compound flammability rating: UL 94V-0
- ◆ Marking : 701
- ◆ Packaging : Tape and Reel per EIA 481

Applications

- ◆ Cell phone handsets
- ◆ Cell phone accessories
- ◆ RF Communications equipment
- ◆ Laptop Computers
- ◆ Two-way pagers
- ◆ GPS Devices

Circuit Diagram

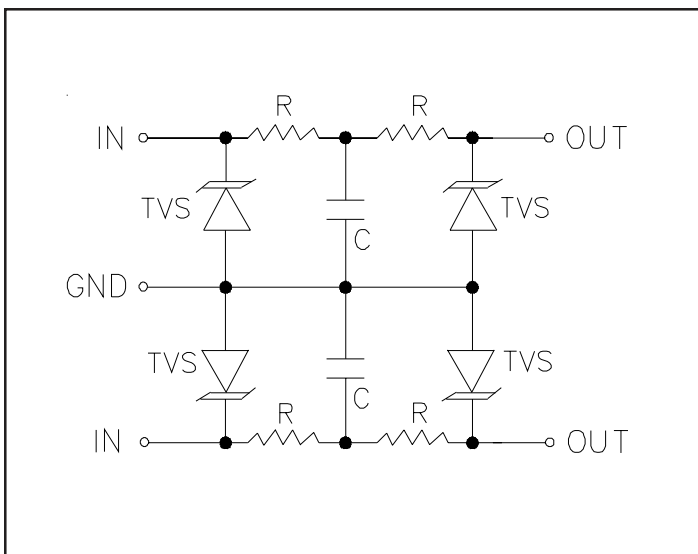

Schematic & PIN Configuration

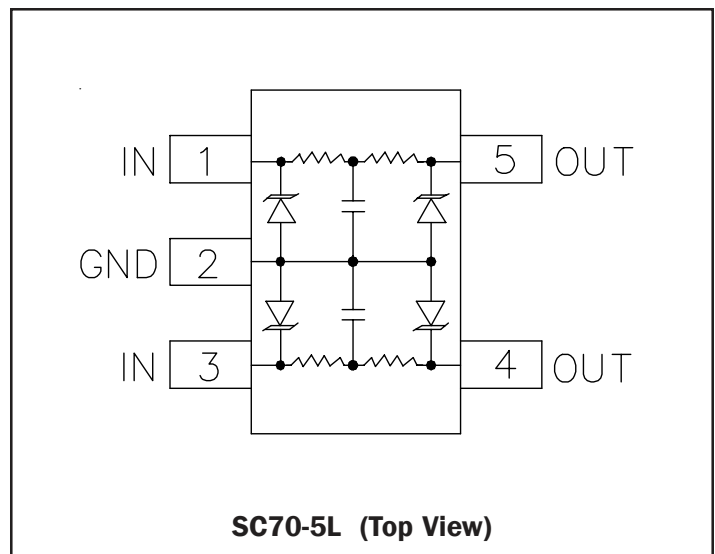

PROTECTION PRODUCTS
Absolute Maximum Rating

Rating	Symbol	Value	Units
Steady-State Power	P_{pk}	100	mW
ESD Air Discharge per IEC 61000-4-2 ESD Contact Discharge per IEC 61000-4-2	V_{ESD}	15 8	kV
Lead Soldering Temperature	T_L	260 (10 sec.)	°C
Operating Temperature	T_J	-20 to +125	°C
Storage Temperature	T_{STG}	-55 to +150	°C

Electrical Characteristics

STF701						
Parameter	Symbol	Conditions	Minimum	Typical	Maximum	Units
TVS Reverse Stand-Off Voltage	V_{RWM}				5	V
TVS Reverse Breakdown Voltage	V_{BR}	$I_t = 1mA$	6			V
TVS Reverse Leakage Current	I_R	$V_{RWM} = 5V, T=25^\circ C$			5	μA
TVS Reverse Leakage Current	I_R	$V_{RWM} = 3.3V, T=25^\circ C$			1	μA
TVS Junction Capacitance	C_j	Between I/O pins and Ground, each device $V_R = 0V, f = 1MHz$		65		pF
Total Series Resistance	R	Each Line	45	50	55	Ω
Capacitor	C	Each Line		100		pF
Total Capacitance	C_{TOT}	Between Input and Output, each Line $V_R = 0V, f = 1MHz$		230		pF

PROTECTION PRODUCTS

Typical Characteristics

Normalized Breakdown Voltage vs. Temperature

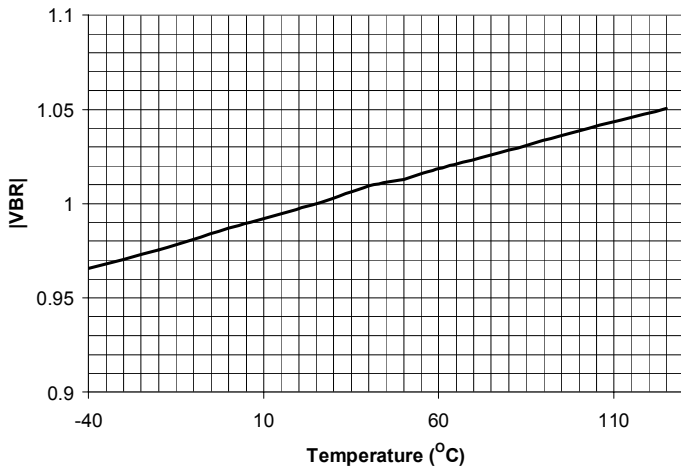

Normalized Resistance vs. Temperature

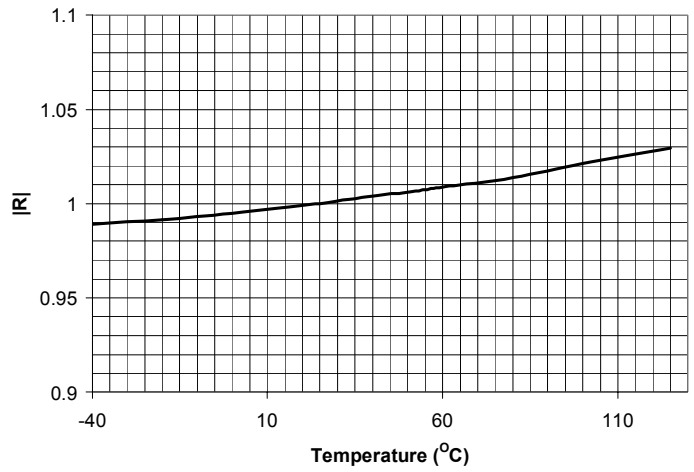

Typical Insertion Loss

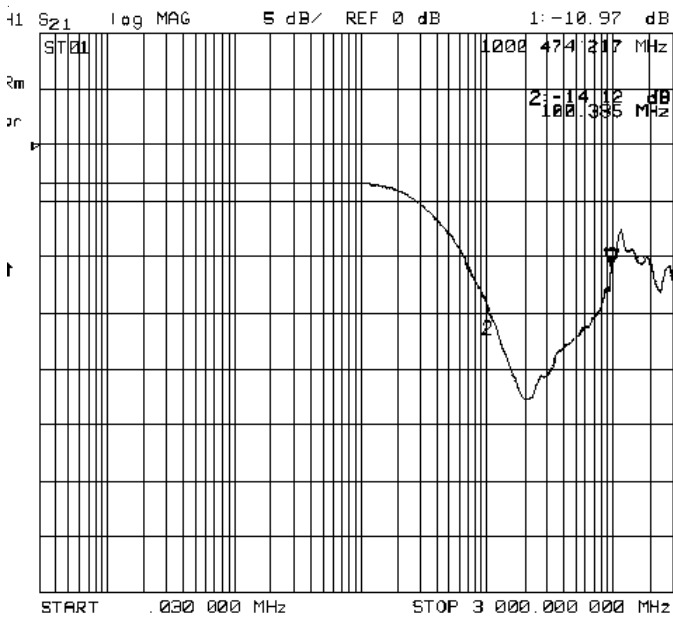

Frequency	Attenuation
100MHz	-10.75dB
1GHz	-14.71dB

Measurement taken with Hewlett Packard Model 8753E Network Analyzer

ESD Clamping
(8kV Contact per IEC 61000-4-2)

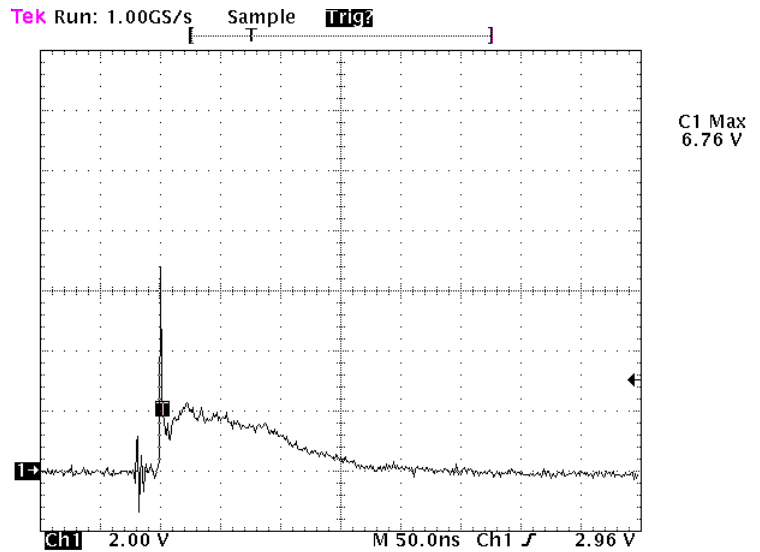

PROTECTION PRODUCTS

Applications Information

Device Connection for Protection of Two Data Lines

The STF701 is designed to provide EMI filtering and ESD protection for two I/O lines. The equivalent circuit diagram is shown in Figure 1. The device is connected as follows:

1. Line 1 is connected at pins 1 & 5 and line 2 is connected at pins 3 & 4 (Figure 2). The device is symmetrical so input & output connections can be made on either side of the device. Pin 2 is connected to ground. The ground connection should be made directly to the ground plane for best results. The path length is kept as short as possible to reduce the effects of parasitic inductance in the board traces.

Voltage Clamping Characteristics.

The clamping characteristics of the STF701 are optimized by the use of two TVS diodes in the protection circuit (Figure 3). An ESD strike on the protected line will be initially suppressed by the first TVS diode. The voltage across the TVS will be the clamping voltage of the device (V_{c1}) given by:

$$V_{c1} = V_{br} + R_D * I_{pp}$$

where

V_{br} = Breakdown voltage of the TVS

R_D = Dynamic resistance of the TVS

I_{pp} = Peak pulse (ESD) current

The dynamic resistance of the TVS is very small, typically $< 0.5\Omega$.

The second TVS will be subjected to V_{c1} through the voltage divider formed by the series resistor (R) and the dynamic resistance of the TVS. Since $R \gg R_D$ then by the voltage divider theorem, the voltage seen by the protected IC will be a few millivolts above the breakdown voltage (V_{br}) of the second TVS.

Figure 1 - STF701 Circuit Diagram

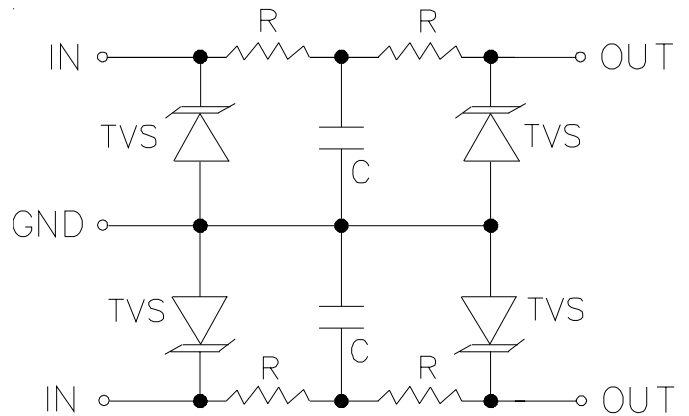

Figure 2 - STF701 Connection Diagram

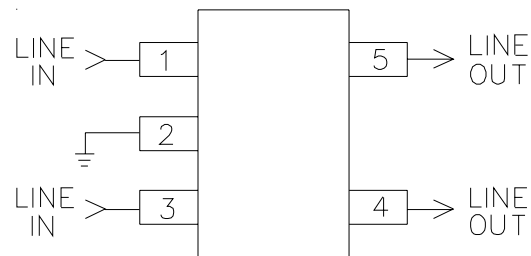
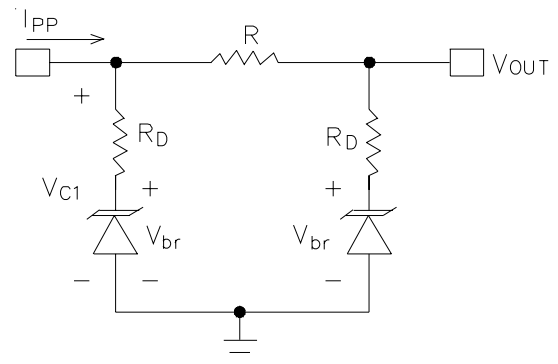
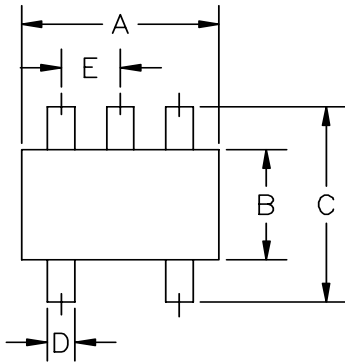

Figure 3 - STF701 Clamping Characteristics



PROTECTION PRODUCTS

Outline Drawing - SC70-5L



DIM ^N	DIMENSIONS ①				NOTE
	INCHES		MM		
	MIN	MAX	MIN	MAX	
A	.071	.087	1.80	2.20	—
B	.045	.053	1.15	1.35	—
C	.071	.094	1.80	2.40	—
D	.006	.012	.150	.300	—
E	.026	BSC	.650	BSC	—
G	.031	.039	.800	1.00	—
H	0.00	.004	0.00	.100	—
J	.004	.007	.100	.180	—
K	.031	.043	.800	1.10	—
L	.004	.012	.100	.300	—

JEDEC EIAJSC70

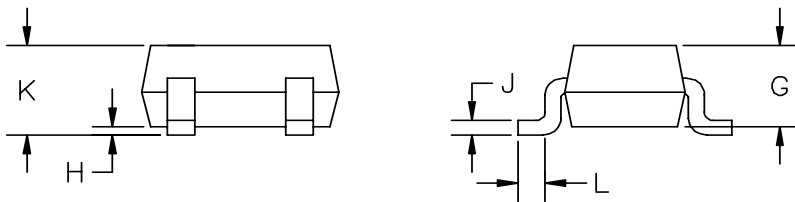

② PACKAGE OUTLINE EXCLUSIVE OF MOLD FLASH AND METAL BURR.

① CONTROLLING DIMENSIONS: MILLIMETERS.

Land Pattern - SC70-5L

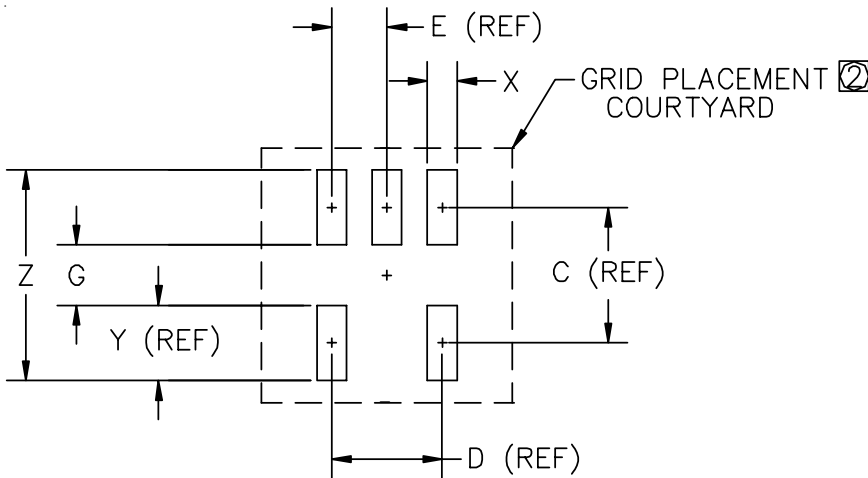

DIM ^N	DIMENSIONS ①				NOTE
	INCHES		MM		
	MIN	MAX	MIN	MAX	
C	—	.063	—	1.60	—
D	—	.052	—	1.30	—
E	—	.026	—	.65	—
G	—	.028	—	.70	—
X	—	.014	—	.35	—
Y	—	.035	—	.90	—
Z	—	.098	—	2.50	—

② GRID PLACEMENT COURTYARD IS 6 x 6 ELEMENTS (3 mm X 3 mm) IN ACCORDANCE WITH THE INTERNATIONAL GRID DETAILED IN IEC PUBLICATION 97.

① CONTROLLING DIMENSION: MILLIMETERS

PROTECTION PRODUCTS**Marking Codes**

Part Number	Marking Code
STF701	701

Ordering Information

Part Number	Working Voltage	Qty per Reel	Reel Size
STF701.TC	5V	3,000	7 Inch
STF701.TG	5V	10,000	13 Inch

Contact Information

Semtech Corporation
Protection Products Division
200 Flynn Road, Camarillo, CA 93012
Phone: (805)498-2111 FAX (805)498-3804