

THIS DRAWING IS UNPUBLISHED. RELEASED FOR PUBLICATION
 © COPYRIGHT - By - ALL RIGHTS RESERVED.

REVISIONS				
P	LTR	DESCRIPTION	DATE	APVD
E1		REVISED PER ECR-17-003845	24MAY17	FV TD

SUGGESTED MATING TAB

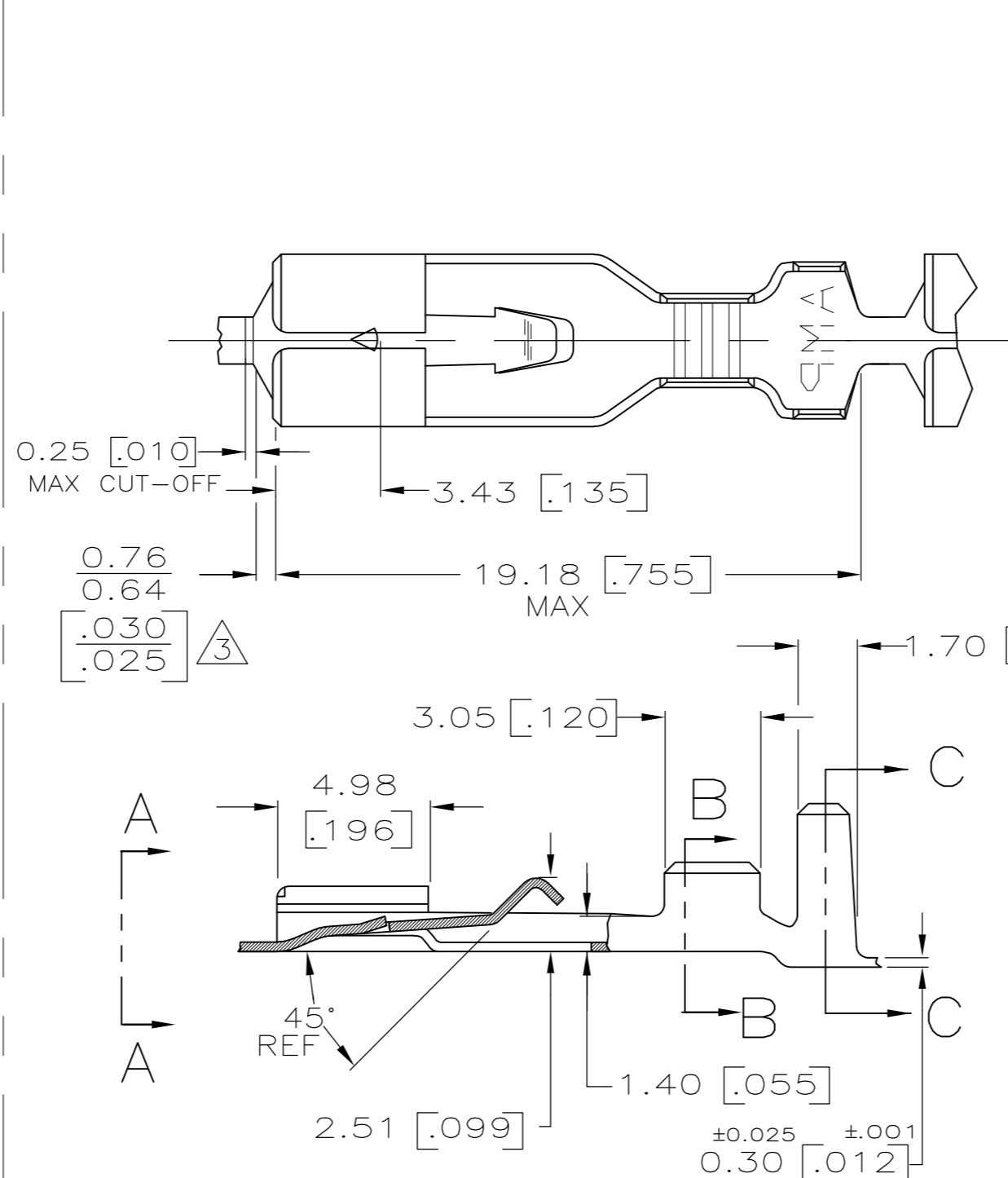
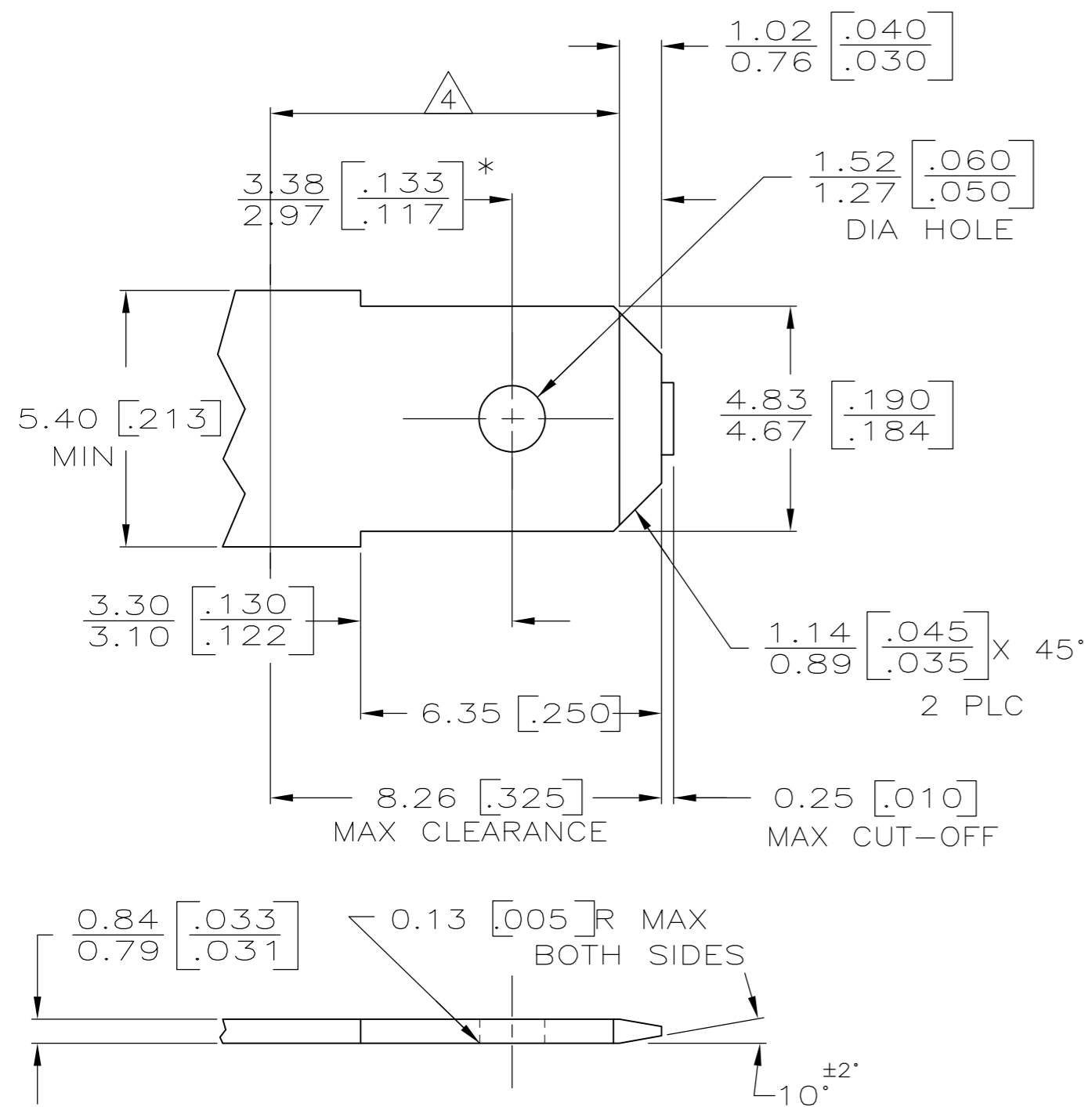

- 1 DIMENSIONS IN BRACKETS ARE IN INCHES.
- 2 CONTINUOUS STRIP ON REELS.
- 3 THIS DIMENSIONS MUST BE MAINTAINED FOR PROPER FUNCTION OF THE LATCHING MECHANISM.
- 4 TO BE REELED WITH INTERLEAVING PAPER

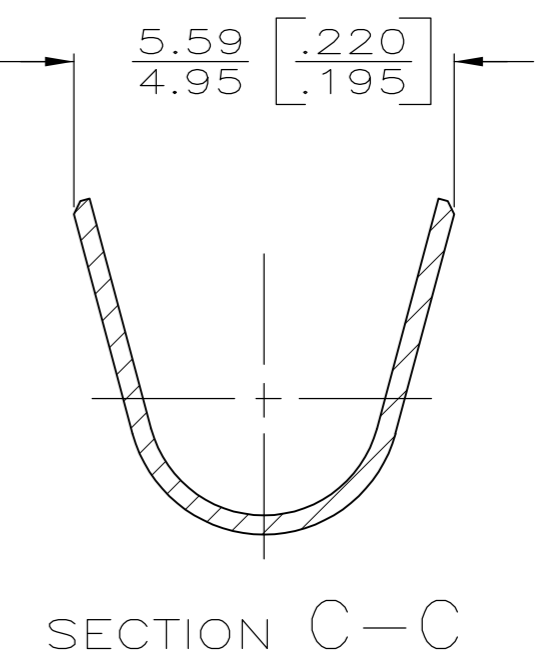
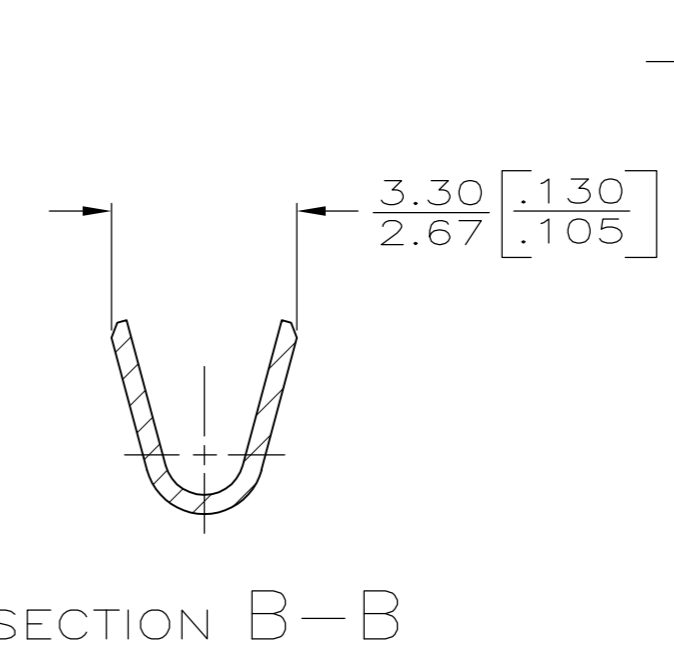
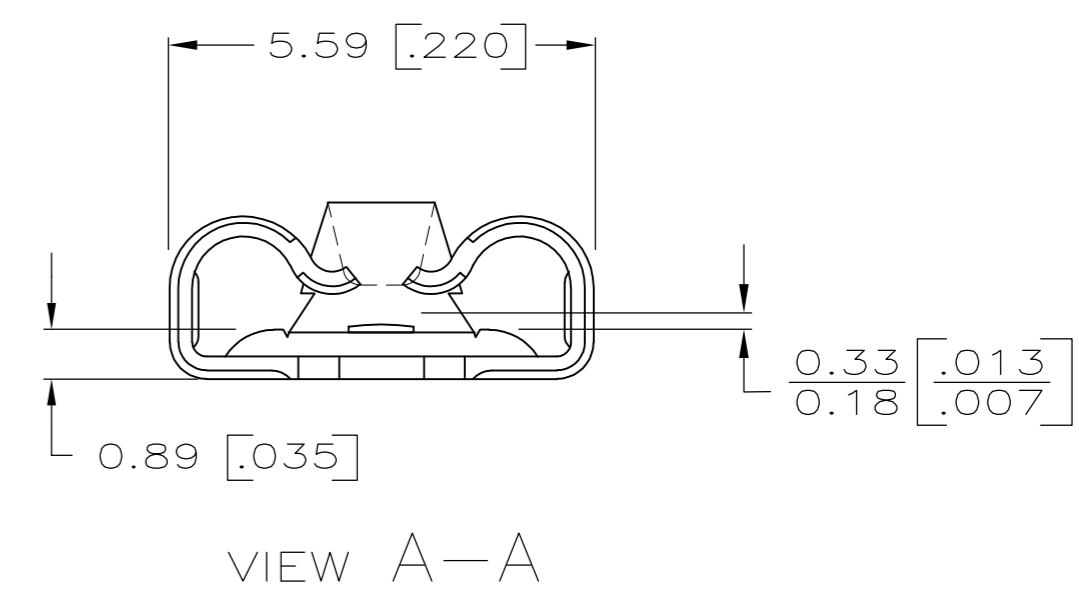

- 1 MATL: #2 HARD BRASS OR NICKEL PLATED STEEL.
- 2 NO BURRS PERMISSIBLE AT HOLE.
- 3 TIN PLATING IS REQUIRED ON BRASS WHEN TERMINAL TEMPERTURE IS OVER 225°F
- 4 MUST BE FLAT WITHIN 0.076 [0.003] OVER THIS LENGTH.
- 5 HOLE MUST BE SYMMETRICAL ABOUT TAB Q WITHIN 0.076 [0.003].
- * TO BE USED ONLY WHEN SHOULDER IS ELIMINATED.

2.29 - 3.30 [0.090 - .130]	0.5 - 1.4mm ² [20-16]	4 63313-1
INSULATION RANGE	WIRE SIZE	PART NO.
THIS DRAWING IS A CONTROLLED DOCUMENT.		DWN 5/27/87
DIMENSIONS: mm [INCHES]		CHK 6/2/87
TOLERANCES UNLESS OTHERWISE SPECIFIED:		APVD 6/2/87
0 PLC ± -		NAME
1 PLC ± -		TE Connectivity
2 PLC ± -		RECEPTACLE, POSITIVE LOCK, .187 SERIES
3 PLC ± 0.25 .010		SIZE CAGE CODE DRAWING NO
4 PLC ± -		A2 00779 C=63313
ANGLES ± -		RESTRICTED TO
FINISH		WEIGHT 0.000000
MATERIAL BRASS	FINISH TIN	CUSTOMER DRAWING
SCALE 1:1		SHEET 1 OF 1
REV E1		