

THIS DRAWING IS UNPUBLISHED. RELEASED FOR PUBLICATION  
 © COPYRIGHT BY TYCO ELECTRONICS CORPORATION. ALL RIGHTS RESERVED.

LOC	DIST	REVISIONS			
P	LTR	DESCRIPTION	DATE	DWN	APVD
AJ	00	B	REV PER ECO 07-027471	1/25/2008	DW JL

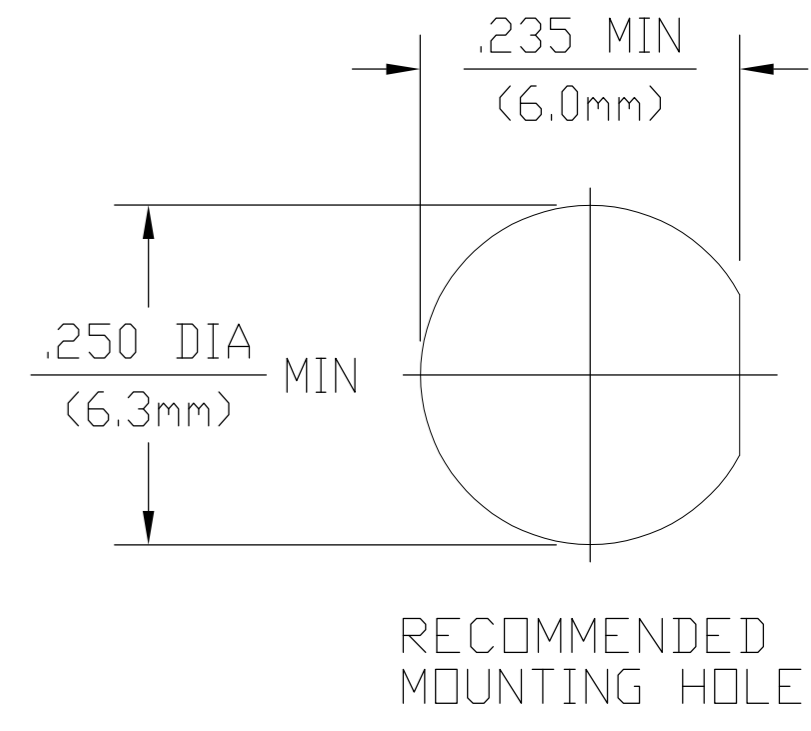
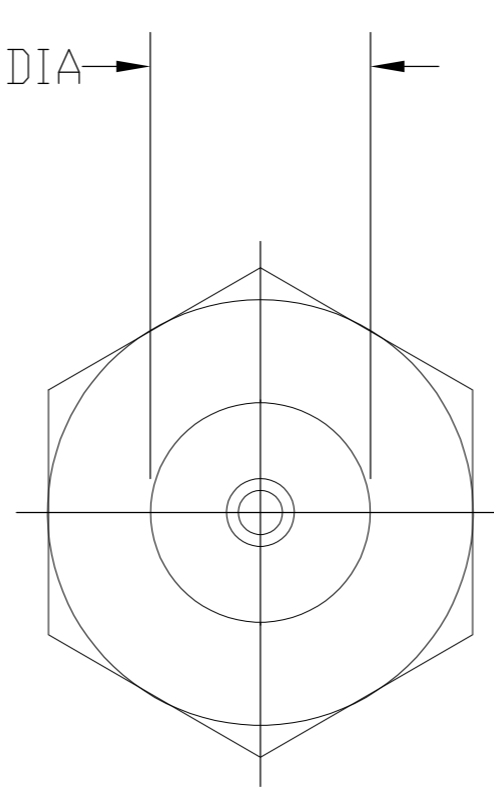
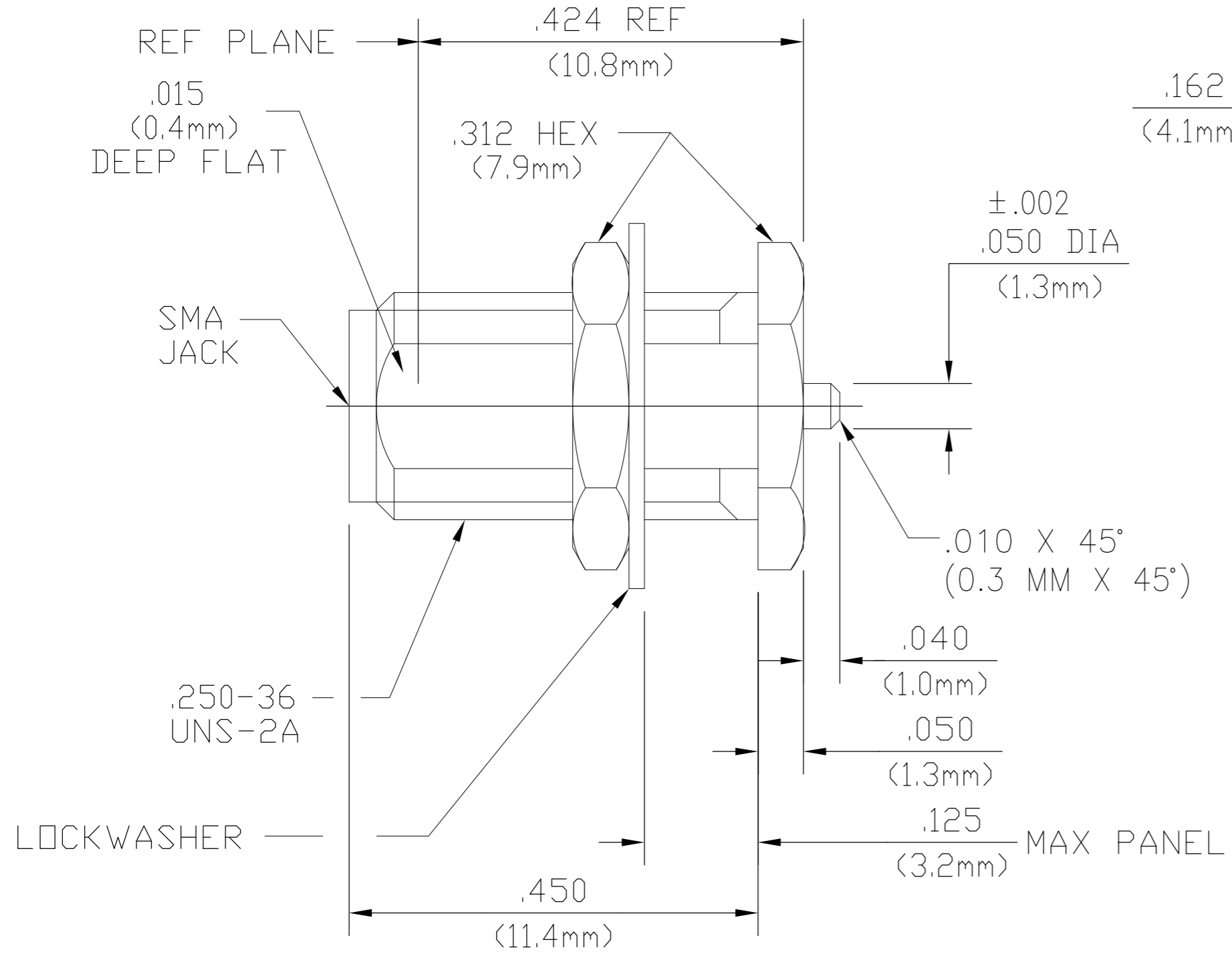

**DESIGN CONTROL REQUIRED**

ELECTRICAL	MECHANICAL	ENVIRONMENTAL
Nominal Impedance (Ohms) <u>50</u>	Interface Dimensions MIL-STD-348, Fig. 310.2	TEMPERATURE RATING <u>-65°C TO +125°C</u>
Frequency Range (GHz) <u>DC to 18</u>	Recommended Mating Torque <u>N/A</u>	Vibration MIL-STD-202, Method 204, Condition D
Volt Rating (VRMS MAX) @ Sea Level <u>335</u>	Mating Characteristics: Insertion (MAX Lbs) <u>3.0</u>	Shock MIL-STD-202, Method 213, Condition I
VSWR <u>1.07+.010f(GHz)</u>	Withdrawal (MIN Oz) <u>1.0</u>	Thermal Shock MIL-STD-202, Method 107, Condition B
Insertion Loss (dB MAX) <u>.04 √f(GHz)</u>	Force to Engage and Disengage (In/Lbs MAX) <u>2.0</u>	Moisture Resistance MIL-STD-202, Method 106, Except Vibration
RF Leakage (dB MIN) <u>-[90-f(GHz)]</u>	Center Contact Captivation Axial (Lbs) <u>6.0</u>	Shall Be Omitted. Insulation Resistance Shall Be 200 Megohms Minimum Within 5 Minutes Of Removal From Humidity
Corona, 70,000 Ft (VRMS MIN) <u>250</u>	Cable Retention Axial Force (Lbs) <u>N/A</u>	Corrosion - MIL-STD-202, Method 101, Condition B, 5% salt spray
Dielectric Withstanding Voltage (VRMS MIN) @ Sea Level <u>1000</u>	Torque (In/Oz) <u>N/A</u>	
Contact Resistance (Milliohms MAX) Center Contact <u>2.0</u>	Weight (Grams) <u>TBD</u>	
Outer Contact <u>2.0</u>		
Cable to Housing <u>N/A</u>		
RF High Potential @ Sea Level (VRMS MIN @ 5 MHz) <u>670</u>		
I.R.(Megohms MIN) <u>5000</u>		

COMPONENT	MATERIAL	FINISH
HOUSING MOUNTING NUT	STAINLESS STEEL PER ASTM-A484 AND ASTM-A582, TYPE 303	GOLD PLATE PER MIL-G-45204
DIELECTRIC	TFE FLUOROCARBON PER ASTM-D-1457	N/A
CENTER CONTACT	BERYLLIUM COPPER PER ASTM-B196, ALLOY 173	GOLD PLATE PER MIL-G-45204
LOCKWASHER	PHOSPHOR BRONZE PER QQ-B-750, GRADE B2 OR TIN BRASS PER ASTM-B-591	GOLD PLATE PER MIL-G-45204

THIS DRAWING IS A CONTROLLED DOCUMENT.

DWN	D.CAM	2/23/95
CHK	-	-
APVD	D.CAM	2/23/95
PRODUCT SPEC	-	-
APPLICATION SPEC	-	-
WEIGHT	-	-
CUSTOMER DRAWING	SCALE 1:1	SHEET 1 OF 1

**Tyco Electronics** Tyco Electronics Corporation  
Harrisburg, PA 17105-3608

NAME: SMA BULKHEAD FEEDTHRU REAR MOUNT JACK RECEPTACLE CHAMFERED TERMINAL (1250-2226-94)

SIZE: A2 CAGE CODE: 00779 DRAWING NO: 1046297-1 RESTRICTED TO: -

1046297-1