

Mechanical Dimensions: Inches [mm]

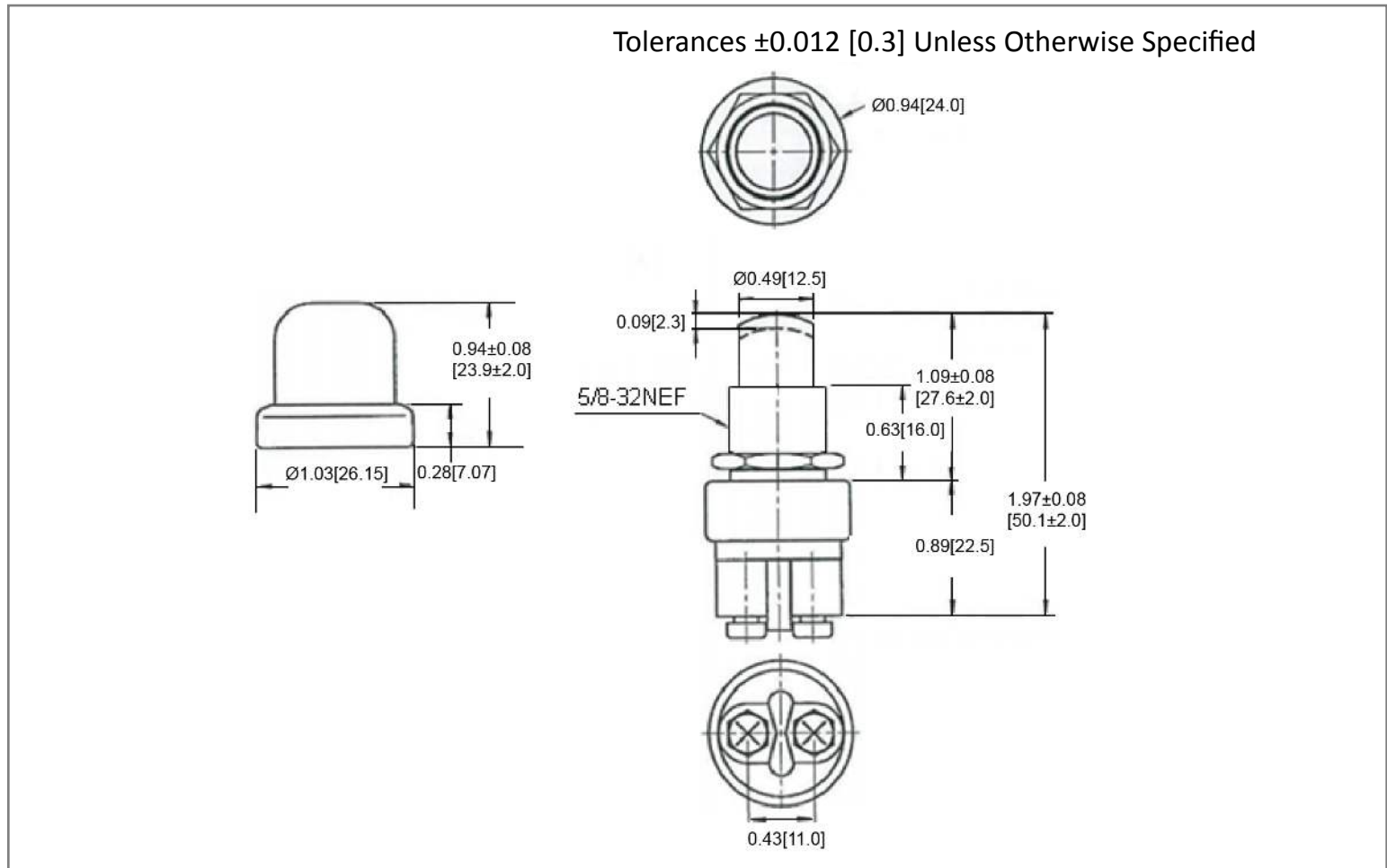

Mounting Hole

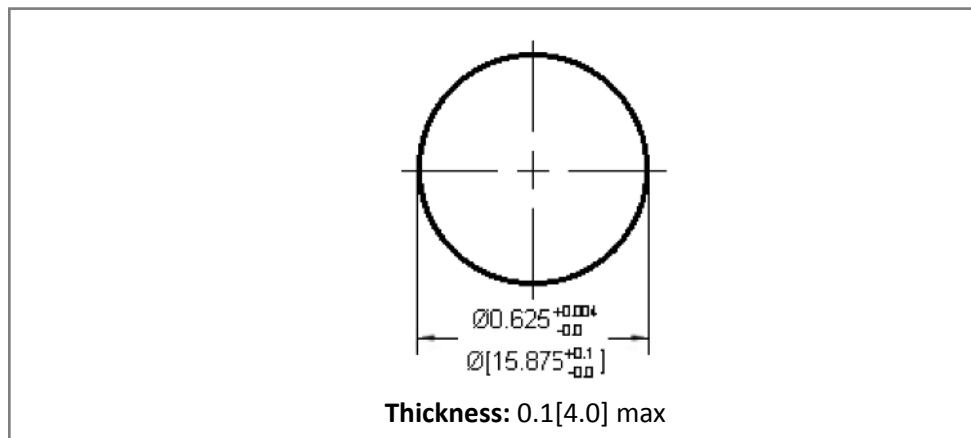

Circuit Diagram

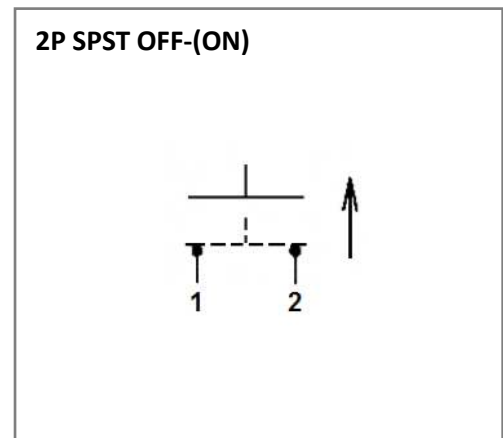

Electrical Specifications

Rating	60A 12V DC
Contact Resistance	50m ohm Max.
Insulation Resistance	DC 500V 100M ohm Min
Dielectric Strength	AC 1500V 1 minute
Operation Temperature	-20°C ~ 85°C

Material Specifications

Frame	Heavy duty die cast construction
Cover	Rubber boot seal (Black EPDM material)
Terminals	Copper alloy (Brass)

Rev Date of issue Revision Notes

Designed Approved

B	05-17-2021	Initial Drawing	RC	OF
---	------------	-----------------	----	----