

SPECIFICATION CONTROL DRAWING

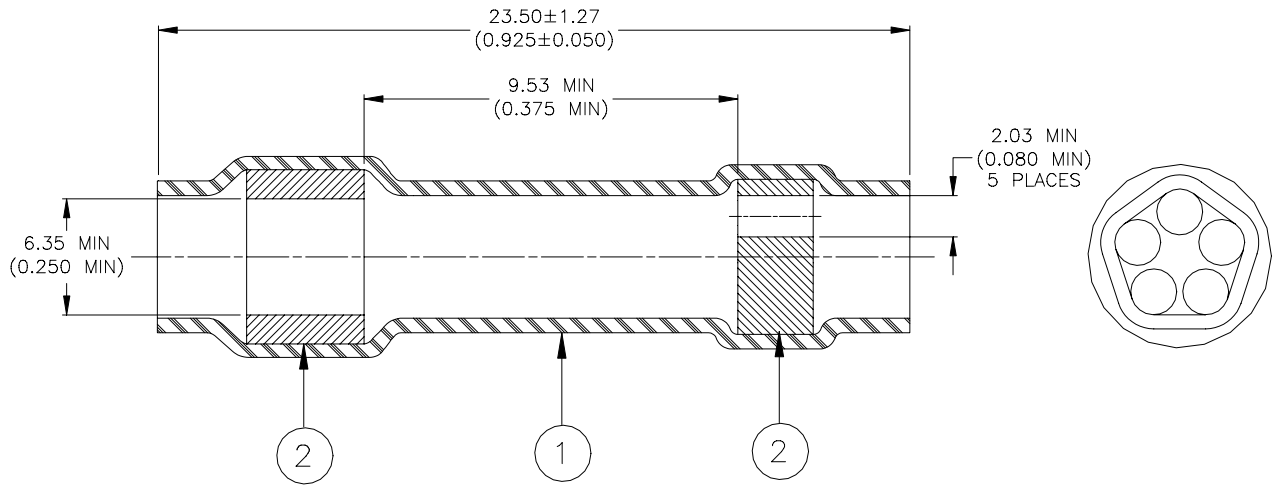

MATERIALS

1. **INSULATION SLEEVE:** Heat-shrinkable, transparent blue, radiation cross-linked modified polyvinylidene fluoride.

Recovered Dimensions: I.D.: 3.18 max (0.125 max)

Wall Thickness: 0.33 min. (0.013 min)

2. **SEALING INSERTS:** Fluorocarbon-based thermoplastic, Color: natural.

APPLICATION

1. This part is designed to provide an environment resistant seal on stub or parallel splices, having no more than two wires, rated for at least 135°C, exiting from any one hole.
2. To install parts, insert wires through multi-holed insert and make crimp in usual manner. Reposition sleeve so that crimp barrel is between the two inserts. Hold sleeve in this position by squeezing the wires behind the multi-hole insert. Heat sleeve using a Raychem approved convection heater. Apply heat first to multi-hole insert end of sleeve until the insert melts and flows, then heat other insert until it flows.
3. Maximum weight of part: 0.52 grams.

| | | | | | | | |
|---|---|---|-----------------|---|------------|-------------------------|--|
| Raychem Interconnect <small>a division of Tyco Electronics</small> 300 Constitution Drive Menlo Park, CA 94025, USA | | THERMOFIT DEVICES | | TITLE : SEALING SLEEVE, STUB SPLICE | | | |
| UNLESS OTHERWISE SPECIFIED DIMENSIONS ARE IN MILLIMETERS. INCHES DIMENSIONS ARE BETWEEN BRACKETS. | | | | DOCUMENT NO.: D-436-46 | | | |
| TOLERANCES: 0.00 N/A 0.0 N/A 0 N/A | ANGLES: N/A ROUGHNESS IN MICRON | Raychem reserves the right to amend this drawing at any time. Users should evaluate the suitability of the product for their application. | | DCR NUMBER: D000568 | | REPLACES: N/A | |
| DRAWN BY: M. FORONDA | DATE: 02-Oct-00 | PROD. REV. K | DOC ISSUE: 1 | SCALE: None | SIZE: A | SHEET: 1 of 1 | |

If this document is printed it becomes uncontrolled. Check for the latest revision.